



*Model PCXB/G-8HR12 Surface Mount Bench  
with Hot-Dip Galvanized Frames, 8 Ft. long with 12" (nom.) wide  
Red Plastisol Coated Perforated Steel seat and back.*

- **Extra heavy design to be stronger and more stable with a simple, clean style**
- **Sturdy, formed and welded steel frame construction**
- **Frames are Hot-Dip Galvanized after fabrication for superior corrosion resistance**
- **Plastisol Coating heat fused to Perforated Steel Seat and Back**
- **Vinyl Plastisol formulated with U.V. stabilizers for ultraviolet protection**
- **Quality construction throughout**

#### **AVAILABLE OPTIONS**

- 4', 6', or 8' models
- Powder Coat Finish in choice of colors or Black Enamel
- Painted steel frame components
- Choice of colors of Plastisol Coating
- 10" or 12" seat and back width
- Armrests

#### **SPECIFICATIONS:**

- **Model PCXB** end frames shall be one-piece, welded construction with a back and seat bracket of 2-3/8" x 1-1/2" x 1/8" nominal sized, die-formed channel, and a 2.375" (2-3/8") O.D. post and foot to meet 2" nominal steel pipe size specifications. Frame foot shall be formed with flattened and rounded ends. A 9/16" hole shall be provided in each end of foot for optional surface mounting with concrete anchors (anchors not included).
- **Model PCXB/G-4** shall be 4 ft. long (nom.).
- **Model PCXB/G-6** shall be 6 ft. long (nom.) with diagonal braces.
- **Model PCXB/G-8** shall be 8 ft. long (nom.) with diagonal braces.
- **Standard:** Frames and diagonal braces shall be hot-dip galvanized after fabrication to ASTM-A123 to maintain an average zinc coating of 2.0 oz. per sq. ft. of surface area (indicated by "/G" in model no.).
- **Standard:** Seat and back shall each be 12" wide one-piece welded construction, fabricated from 14 ga. perforated steel surface with 10 ga. x 2-1/2" roll-formed vertical edges on all sides and reinforced by a 10 ga. x 2-1/4" x 1-1/4" die-formed angle substructure. Substructure shall include all mounting holes for easy assembly.
- **Standard:** All steel surfaces of the seat and back shall be covered with a 125 mil (1/8") average coating for an overall average thickness, including top and bottom coatings, of 250 mils (1/4") of permanently heat-fused Brown (indicated by "HW" in model number) vinyl Plastisol formulated with high impact additives and UV inhibitors.
- All 3/8" dia. galvanized carriage bolts and nuts shall be provided to fasten frames to seat and back.
- **Optional:** Frames shall be finished in black enamel paint. (To specify, change "/G" to "/B" in model no., e.g. PCXB/B-4HW12.)
- **Optional:** Color choices of powder coated steel frame components. For optional colors choices see Specification Bulletin # SPC-CO-001.
- **Optional:** Color choices of plastisol coated steel components. For optional colors choices see Specification Bulletin # SPC-CO-001.
- **Optional:** Seat and back shall each be a 10" wide one-piece welded construction with 10 ga. x 2-1/2" (2" on 4 ft. models) roll-formed vertical edges on all sides. Indicate choice by changing "12" in model no. to "10", e.g. PCXB/G-4HW10.

**R.J. THOMAS MFG. CO., INC.**

P.O. Box 946 • Cherokee, IA 51012-0946 • PH: 712-225-5115 • 800-762-5002 • FAX: 712-225-5796

E-mail: [pilotrock@rjthomas.com](mailto:pilotrock@rjthomas.com) • Web Site: <http://www.pilotrock.com>

© 2005 R. J. Thomas Mfg. Co., Inc. PILOT ROCK® Park Equipment is a registered trademark of R. J. Thomas Mfg. Co., Inc.

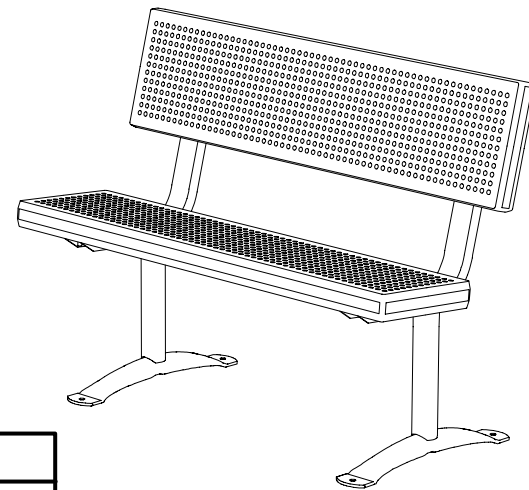
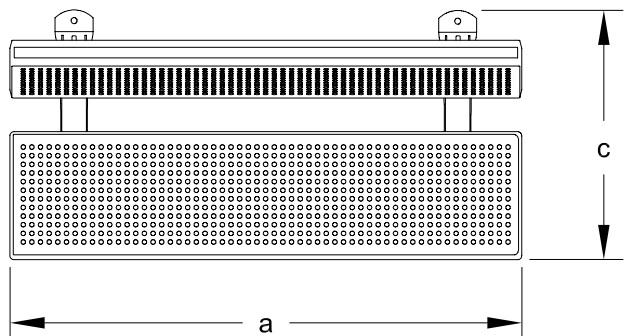

MODEL NUMBER	DIMENSION			
	a	b	c	d
PCXB-4-10	44	30	20-1/16	35
PCXB-6-10	72	51-3/4	20-1/16	35
PCXB-8-10	96	70	20-1/16	35
PCXB-4-12	48	36	21-1/16	36
PCXB-6-12	72	51-3/4	21-1/16	36
PCXB-8-12	96	70	21-1/16	36

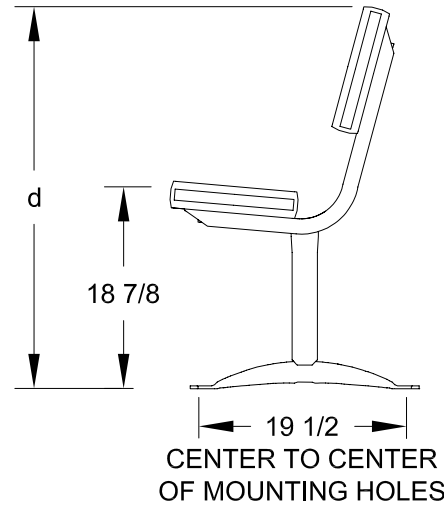
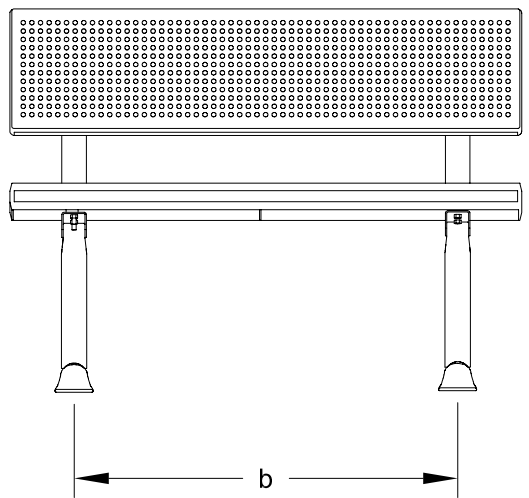

\*CTR TO CTR  
OF FRAME POSTS

ALL DIMENSIONS IN INCHES

R. J. **THOMAS MFG. Co., INC.**  
P.O. Box 946 • Cherokee, IA 51012

DRAWN BY  
**WWM**

TITLE MODEL PCXB EXTRA HEAVY DUTY 4, 6 AND 8 FOOT PORTABLE/SURFACE MOUNT  
BENCH WITH PLASTISOL COATED PERFORATED STEEL SEAT AND BACK

DATE 4-05-05

DWG. NO. **AI-1643**