



*Model PWB/G-4PN 4 Ft. Surface Mount Bench
with Hot Dip Galvanized Frames
and Green Recycled Plastic 4" x 4" timbers.
Shown with optional armrests Model AR/G-5PN*

- **Sturdy, formed and welded steel construction**
- **Flat design with Bull-nosed outside timbers**
- **100% Recycled Plastic seat timbers with solid color and U.V. stabilizer for ultraviolet protection**
- **Precision drilled plastic timbers**
- **Fast, easy assembly using 3/8" dia. galvanized carriage bolts**
- **Quality construction throughout**

SPECIFICATIONS:

- **Model PWB** end frames shall be one-piece welded construction with 2-1/2" x 2-1/2" square steel post. Seat bracket shall be constructed of 3/8" x 4" A-36 flat steel bar, die-formed for shape and reinforcement, to mount four 4" x 4" timbers. A welded-on foot of formed 3/8" x 4" A-36 flat steel bar provides two 25/32" holes for anchoring to hard surfaces (anchor bolts not included).
- **Model PWB-4PC** shall be a nom. 4 ft. in length with two (2) frames.
- **Model PWB-6PC** shall be a nom. 6 ft. in length with two (2) frames.
- **Model PWB3-8PC** shall be a nom. 8 ft. in length with three (3) frames.
- **Standard:** Finish shall be hot-dip galvanized after fabrication to ASTM-A123 to maintain an average zinc coating of 2.0 oz. per sq. ft. of surface area (indicated by "/G" in model no.).
- 3/8" galvanized carriage bolts and nuts shall be provided for timber connections.
- **Standard:** Seat shall be made of 100% Recycled Plastic molded into 4" x 4" nominal sized timbers with solid Cedar color (indicated by "PC" in model no.) formed throughout and a U.V. stabilizer added for ultraviolet protection.
- **Optional:** Color choices of powder coated steel frame components. For optional colors choices see Specification Bulletin # SPC-CO-001.
- **Optional:** Frame shall be finished in Black enamel paint. To specify, change "/G" in model no. to "/B", e.g. PWB/B-6PC.
- **Optional:** Color choices of Recycled Plastic components. For optional colors choices see Specification Bulletin # SPC-CO-001.
- **Optional:** In lieu of carriage bolts, zinc plated lag screws shall be provided for timber connections – please specify when ordering.

AVAILABLE OPTIONS

- 4', 6', or 8' models
- Powder Coat Finish in choice of colors or Black Enamel
- Painted steel frame components
- Choice of colors of Recycled Plastic
- Armrests

R.J. THOMAS MFG. CO., INC.

P.O. Box 946 • Cherokee, IA 51012-0946 • PH: 712-225-5115 • 800-762-5002 • FAX: 712-225-5796

E-mail: pilotrock@rjthomas.com • Web Site: <http://www.pilotrock.com>

© 2005 R. J. Thomas Mfg. Co., Inc. PILOT ROCK® Park Equipment is a registered trademark of R. J. Thomas Mfg. Co., Inc.

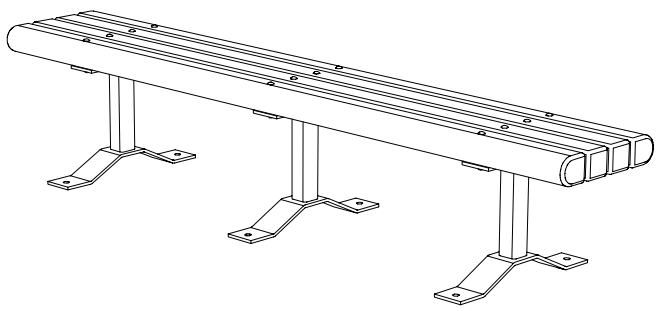
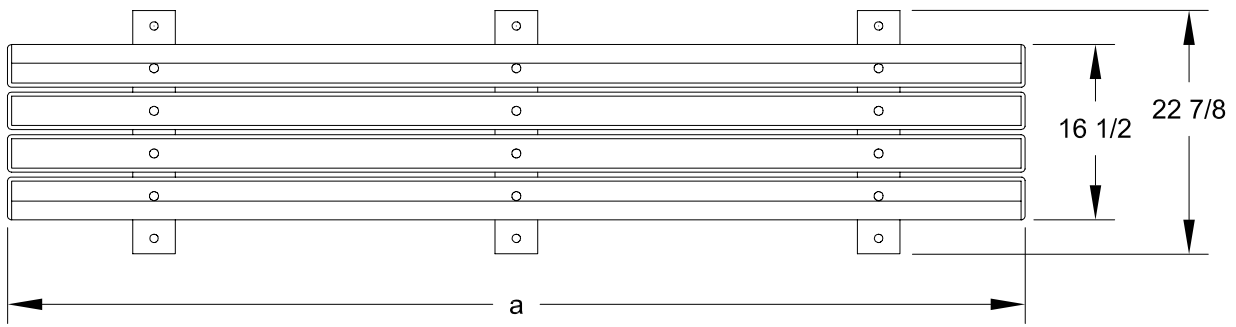

MODEL NUMBER	DIMENSION		
	a	b	c
PWB-4	47-1/2	N/A	36
PWB-6	71-1/2	N/A	48
PWB-8	95-1/2	34	68

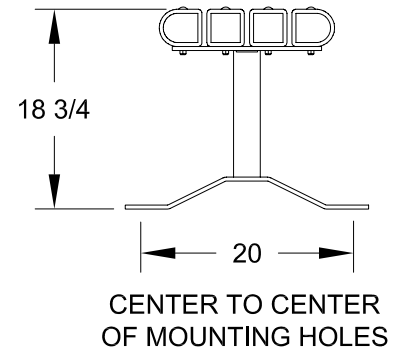
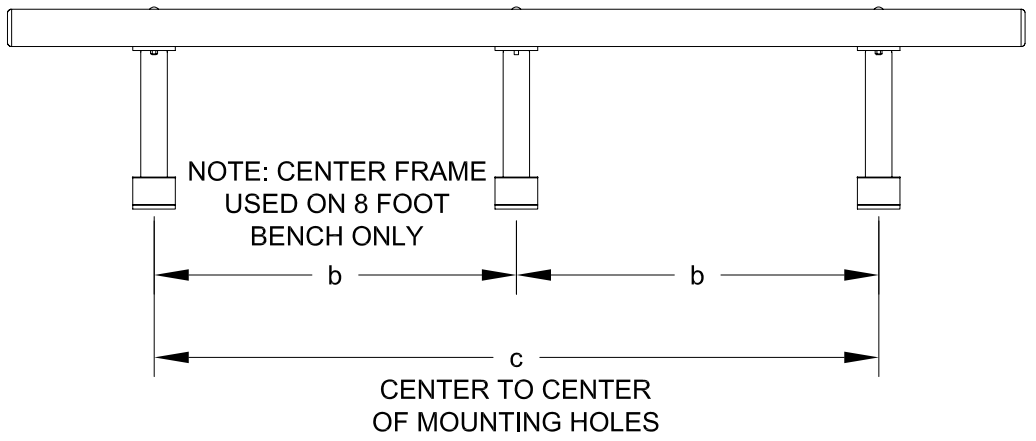

ALL DIMENSIONS IN INCHES

R. J. THOMAS MFG. Co., INC. P.O. Box 946 • Cherokee, IA 51012	DRAWN BY WWM	TITLE MODEL PWB 4, 6, AND 8 FOOT PORTABLE/SURFACE MOUNT FLAT BENCH WITH 4" X 4" RECYCLED PLASTIC TIMBERS	DATE 4-20-05
			DWG. NO. AI-1653