



Model PWRB/G-6PC 6 Ft. Portable/Surface Mount Bench
with Hot Dip Galvanized Frames
and Cedar colored Recycled Plastic 4" x 4" timbers.

- **Sturdy, formed and welded steel construction**
- **Contour design with Bull-nosed top and front timbers**
- **100% Recycled Plastic seat and back timbers with solid color and U.V. stabilizer for ultraviolet protection**
- **Precision drilled plastic timbers**
- **Fast, easy assembly using 3/8" dia. galvanized carriage bolts**
- **Quality construction throughout**

AVAILABLE OPTIONS

4', 6', or 8' models
Black, Green or Brown Powder Coat or Painted Black
Enamel steel frame components
Choice of 9 colors of Recycled Plastic
Routed Lettering available (call for details)
Armrests

SPECIFICATIONS:

- **Model PWRB** end frames shall be one-piece welded construction with 2-1/2" x 2-1/2" square steel post. Back and seat bracket shall be constructed of 3/8" x 4" A-36 flat steel bar, die-formed for shape and reinforcement, to mount eight 3" x 4" timbers. A welded-on foot of formed 3/8" x 4" A-36 flat steel bar provides two 25/32" holes for anchoring to hard surfaces (anchor bolts not included).
- **Model PWRB-4PC** shall be a nom. 4 ft. in length with two (2) frames.
- **Model PWRB-6PC** shall be a nom. 6 ft. in length with two (2) frames.
- **Model PWRB3-8PC** shall be a nom. 8 ft. in length with three (3) frames.
- **Standard:** Finish shall be hot-dip galvanized after fabrication to ASTM-A123 to maintain an average zinc coating of 2.0 oz. per sq. ft. of surface area (indicated by "/G" in model no.).
- 3/8" galvanized carriage bolts and nuts shall be provided for timber connections.
- **Standard:** Seat shall be made of 100% Recycled Plastic molded into 4" x 4" nominal sized timbers with solid Cedar color (indicated by "PC" in model no.) formed throughout and a U.V. stabilizer added for ultraviolet protection.
- **Optional:** Frames shall be finished in Black, Green, or Brown powder coat. To specify, change "/G" in model no. to "/CB" for Black, "/CN" for Green, or "/CW" for Brown, e.g. PWRB/CN-6PC.
- **Optional:** Frame shall be finished in Black enamel paint. To specify, change "/G" in model no. to "/B", e.g. PWRB/B-6PC.
- **Optional:** 100% Recycled Plastic timbers shall be available in a choice of 8 optional colors. Indicate choice of color by changing "PC" for Cedar color in model no. to: "PA" for Gray; "PW" for Brown; "PN" for Green; "PR" for Red; "PU" for Blue; "PY" for Yellow; "PI" for Ivory; or "PB" for Black, e.g. PWRB/G-6PB.
- **Optional:** In lieu of carriage bolts, zinc plated lag screws shall be provided for timber connections – please specify when ordering.

R.J. THOMAS MFG. CO., INC.

P.O. Box 946 • Cherokee, IA 51012-0946 • PH: 712-225-5115 • 800-762-5002 • FAX: 712-225-5796

E-mail: pilotrock@rjthomas.com • Web Site: <http://www.pilotrock.com>

© 2005 R. J. Thomas Mfg. Co., Inc. PILOT ROCK® Park Equipment is a registered trademark of R. J. Thomas Mfg. Co., Inc.

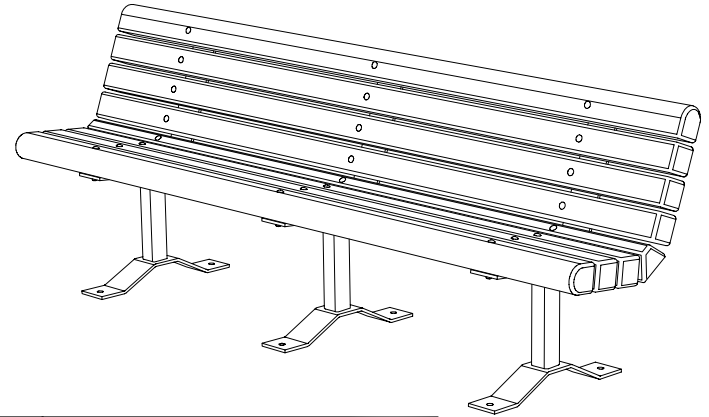
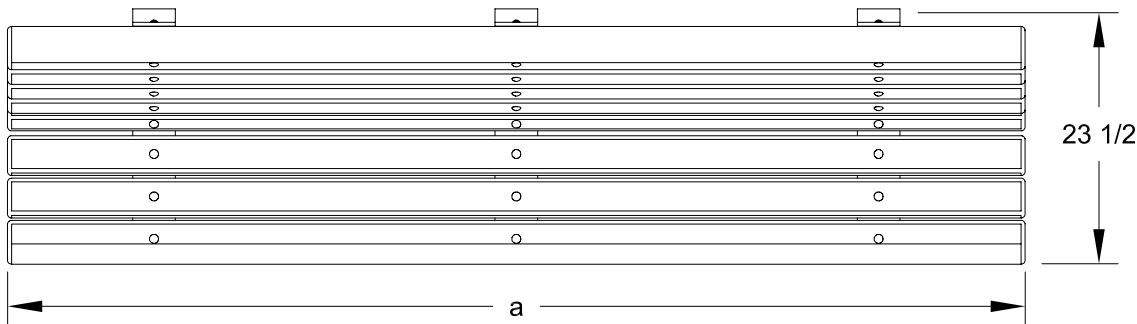

MODEL NUMBER	DIMENSION		
	a	b	c
PWRB-4	47-1/2	N/A	36
PWRB-6	71-1/2	N/A	48
PWRB-8	95-1/2	34	68

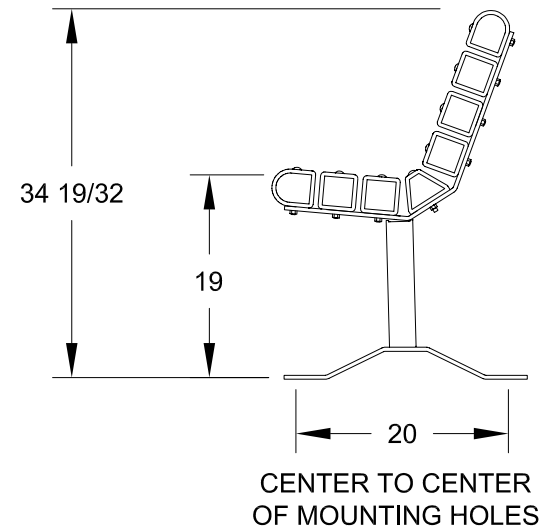
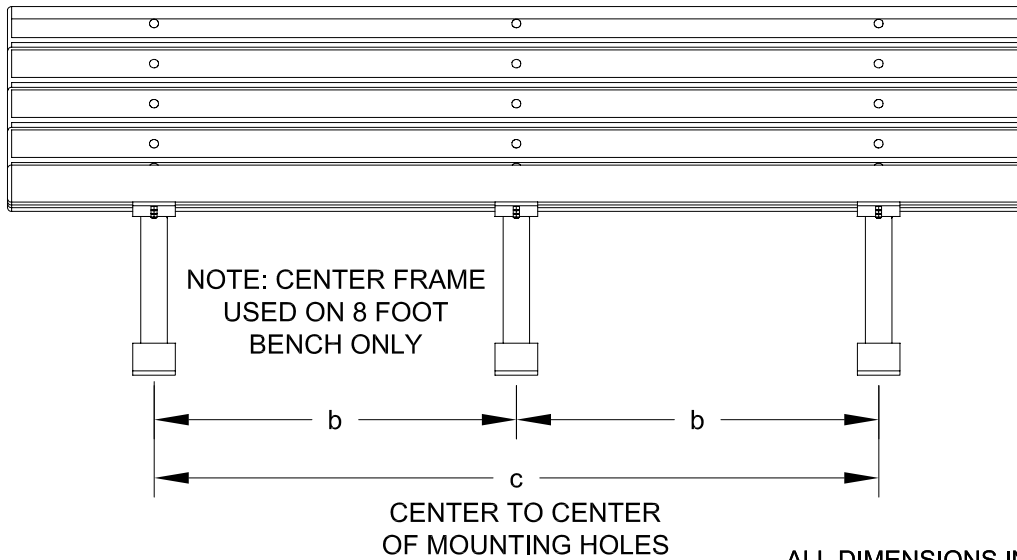

ALL DIMENSIONS IN INCHES

R. J. **THOMAS MFG. Co., INC.**
P.O. Box 946 • Cherokee, IA 51012

DRAWN BY
WWM

TITLE MODEL PWRB 4, 6, AND 8 FOOT PORTABLE/SURFACE MOUNT CONTOUR BENCH
WITH 4" X 4" RECYCLED PLASTIC TIMBERS

DATE 4-26-05

DWG. NO. **AI-1657**