



*Model XT/G-8VN 8 Ft. Extra Heavy Duty Portable
Rectangular Table with Hot Dip Galvanized Frame and
Green Plastisol Coated V-Type Expanded Steel Seats and Top*

- **Frame constructed specifically for heavy use areas**
- **Top and seats designed for more abusive environments such as high elevations where snow loads can destroy average tables**
- **Nontip, nontrip walk-through design**
- **All welded end frames are fabricated from 2-3/8" diameter steel pipe**
- **Diagonal braces align and strengthen entire table**
- **Frames are hot dip galvanized after fabrication for superior corrosion resistance**
- **Plastisol Coating heat fused to Expanded Steel Seats and Top**
- **Vinyl Plastisol formulated with U.V. stabilizers for ultraviolet protection**
- **Fast, easy assembly using 3/8" dia. galvanized bolts**
- **Limited lifetime warranty on frames**

AVAILABLE OPTIONS

- 6' or 8' length
- Powder Coat Finish in choice of colors or Black
- Enamel Painted steel frame components
- Choice of colors of Plastisol Coating

SPECIFICATIONS:

- **XT Series** end frames shall be one-piece welded construction, fabricated from 2.375" O.D. (2-3/8" O.D.) steel pipe to meet 2" nominal steel pipe size specifications with 2" x 2" x 3/16" A-36 structural grade steel angle for attaching the seats and tops.
- Table frame design shall incorporate nontip, nontrip, walk-through design features. Bends shall be tightly formed to prevent tipping when weight is on one side.
- **Model XT/G-6VW** shall be a nominal 6 ft. long.
- **Model XT/G-8VW** shall be a nominal 8 ft. long.
- Nominal table height shall be 30-1/2". Frame design shall provide a nominal 28" of clearance from ground level to the underside of table. Nominal seat height shall be 18-1/2".
- Frames shall be supported by diagonal braces of 1-5/16" O.D. x 14 ga. wall steel pipe that shall connect to the underside of the table top.
- All 3/8" carriage bolts shall be provided to fasten tops and seats to the frames.
- **V-Type** table top and seats shall each be a one-piece welded construction, fabricated from a 3/4-#9 expanded steel surface with 10 ga. x 2-1/2" roll-formed vertical edges on all sides and reinforced by a 10 ga. die-formed angle substructure. Substructure shall include all mounting holes for easy assembly of table.
- **Standard:** All steel surfaces of the top and seats shall be covered with a coating of Brown vinyl Plastisol (indicated by "VW in model no.) formulated with high impact additives, UV inhibitors, and an anti-microbial to resist mold and mildew. Plastisol coating shall be permanently heat-fused to the steel to an average thickness of 125 mils (1/8") for an overall average thickness, including top and bottom coatings, of 250 mils (1/4").
- **Standard:** Frames and diagonal braces shall be hot-dip galvanized after fabrication to ASTM-A123 to maintain an average zinc coating of 2.0 oz. per sq. ft. of surface area (indicated by "/G" in model no.).
- **Optional:** Frames and diagonal braces shall be finished in black enamel. To specify, change "/G" to "/B" in model no., e.g. XT/B-6VW.
- **Optional:** Color choices of powder coated steel frame components. For optional colors choices see Specification Bulletin # SPC-CO-001.
- **Optional:** Color choices of plastisol coated steel components. For optional colors choices see Specification Bulletin # SPC-CO-001.

R.J. **THOMAS MFG. CO., INC.**

P.O. Box 946 • Cherokee, IA 51012-0946 • PH: 712-225-5115 • 800-762-5002 • FAX: 712-225-5796

E-mail: pilotrock@rjthomas.com • Web Site: <http://www.pilotrock.com>

© 2005 R. J. Thomas Mfg. Co., Inc. PILOT ROCK® Park Equipment is a registered trademark of R. J. Thomas Mfg. Co., Inc.

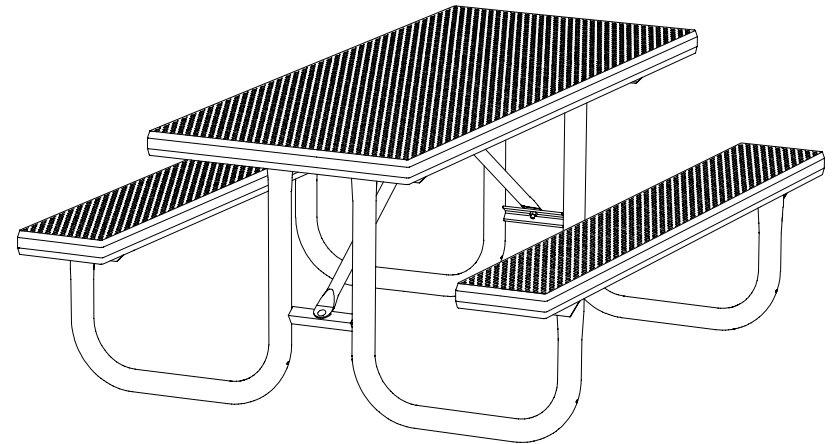
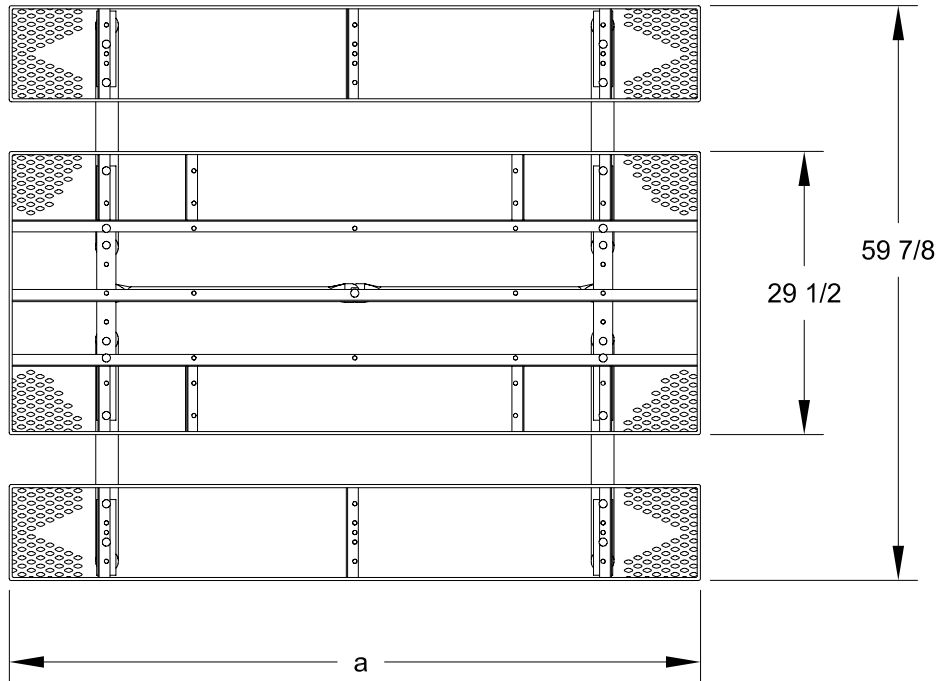

MODEL NUMBER	DIMENSION	
	a	b
XT-6	72	51-3/4
XT-8	96	70

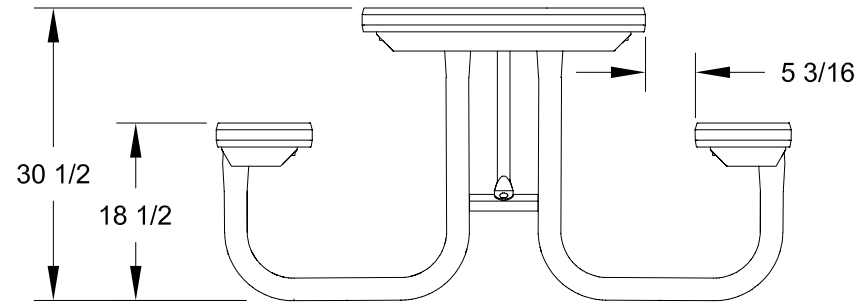
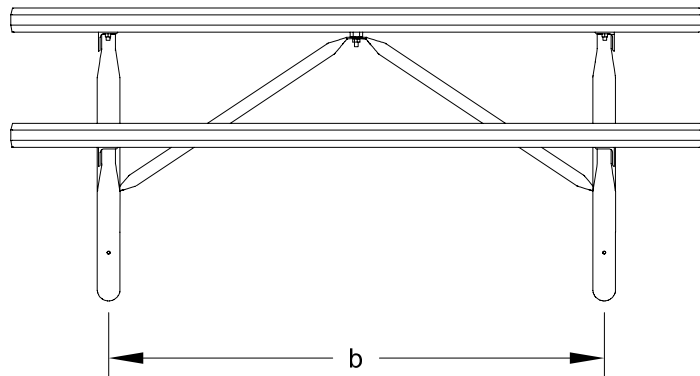

ALL DIMENSIONS IN INCHES

R. J. **THOMAS MFG. CO., INC.**
P.O. Box 946 • Cherokee, IA 51012

DRAWN BY
WWM

TITLE **XT SERIES 6 AND 8 FOOT PORTABLE RECTANGULAR TABLE
WITH V-TYPE PLASTISOL COATED EXPANDED STEEL TOP AND SEATS**

DATE **04-04-06**

DWG. NO. **AI-1479**