



*Model XT/G-6PW 6 Ft. Extra Heavy Duty Portable
Rectangular Table with Hot Dip Galvanized Frame
and Brown 100% Recycled Plastic Planks*

- **Constructed specifically for heavy use areas**
- **Nontip, nontrip walk-through design**
- **All welded end frames are fabricated from 2-3/8" diameter steel pipe**
- **Die-formed center channel and diagonal braces align and strengthen entire table**
- **Frames are hot dip galvanized after fabrication for superior corrosion resistance**
- **100% Recycled Plastic Seat and Top Planks with solid color and U.V. stabilizer for ultraviolet protection**
- **Steel channel reinforcements under seats and table top**
- **Fast, easy assembly using 3/8" dia. galvanized carriage bolts**
- **Limited lifetime warranty on frames**

AVAILABLE OPTIONS

- **6' and 8' lengths**
- **Powder Coat Finish in choice of colors or Black Enamel Painted steel frame components**
- **Choice of colors of Recycled Plastic**

6 and 8 Ft. lengths

SPECIFICATIONS:

- **XT Series** end frames shall be one-piece welded construction, fabricated from 2.375" O.D. (2-3/8" O.D.) steel pipe to meet 2" nominal steel pipe size specifications with 2" x 2" x 3/16" A-36 structural grade steel angle for attaching the seats and tops.
- Table frame design shall incorporate nontip, nontrip, walk-through design features. Bends shall be tightly formed to prevent tipping when weight is on one side.
- Nominal table height shall be 30". Nominal seat height shall be 18". Length shall be per model number, e.g. XT/G-8PW for 8 ft.
- Frames shall be supported by diagonal braces of 1-5/16" O.D. steel pipe that shall connect to a die-formed steel channel designed to align and provide attachment to the table top.
- All 3/8" dia. galvanized carriage bolts and nuts shall be provided to fasten frames and center channel to table top and seats.
- **Standard:** Tops and Seats shall be made of 100% Recycled Plastic molded into 2" x 10" nominal sized planks with solid Brown color (indicated by PW in model no.) formed throughout and a U.V. stabilizer added for ultra-violet protection.
- Recycled Plastic table top and seat planks shall be supported by pregalvanized steel subframe channels.
- **Standard:** Frames, diagonal braces, and center channel shall be hot-dip galvanized after fabrication to ASTM-A123 to maintain an average zinc coating of 2.0 oz. per sq. ft. of surface area (indicated by "/G" in model no.).
- **Optional:** Color choices of powder coated steel frame components. For optional colors choices see Specification Bulletin # SPC-CO-001.
- **Optional:** Frames, diagonal braces and center channel shall be finished in black enamel. To specify, change "/G" to "/B" in model no., e.g. XT/B-6PW.
- **Optional:** Color choices of Recycled Plastic components. For optional colors choices see Specification Bulletin # SPC-CO-001.

R.J. THOMAS MFG. CO., INC.

P.O. Box 946 • Cherokee, IA 51012-0946 • PH: 712-225-5115 • 800-762-5002 • FAX: 712-225-5796

E-mail: pilotrock@rjthomas.com • Web Site: <http://www.pilotrock.com>

© 2003 R. J. Thomas Mfg. Co., Inc. PILOT ROCK® Park Equipment is a registered trademark of R. J. Thomas Mfg. Co., Inc.

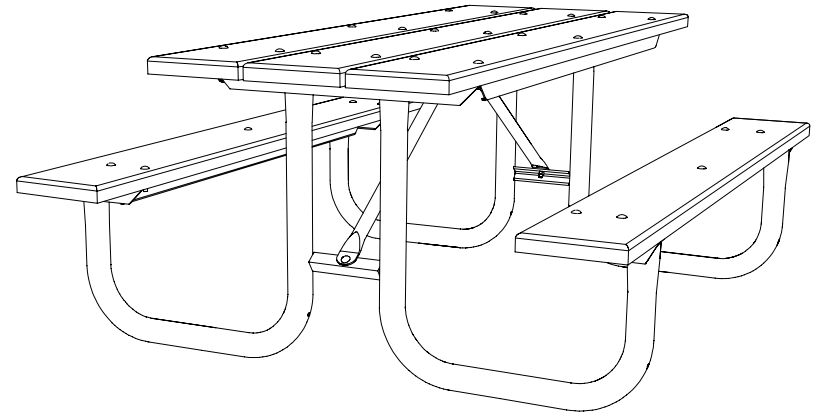
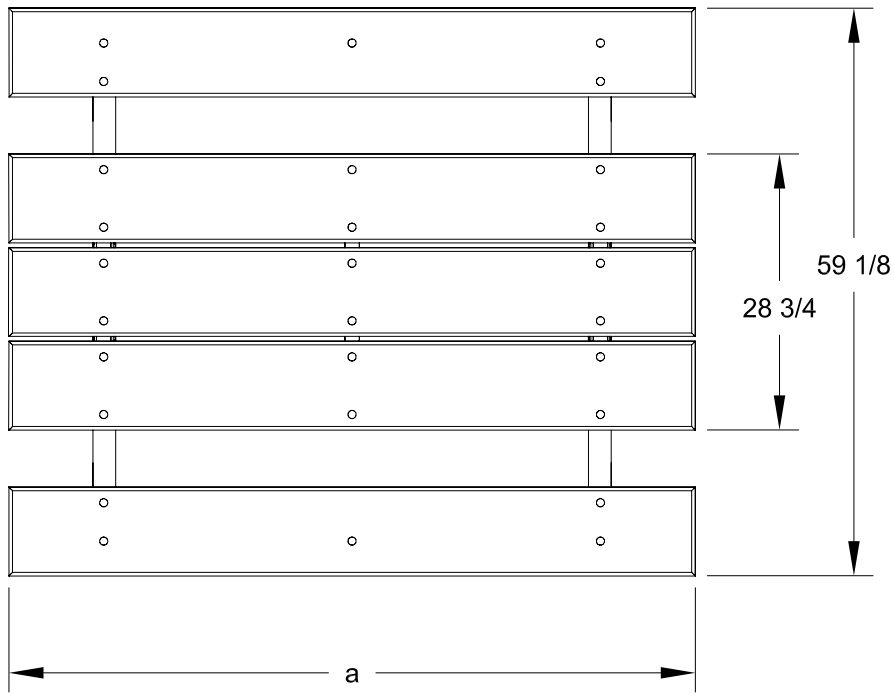

| MODEL NUMBER | DIMENSION | |
|--------------|-----------|--------|
| | a | b |
| XT/G-6 | 71 1/2 | 51 3/4 |
| XT/G-8 | 95 1/2 | 70 |

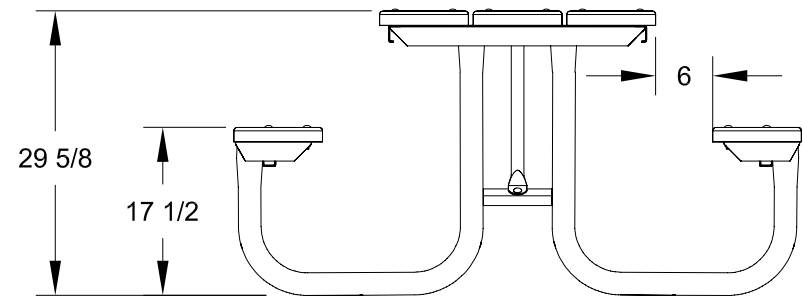
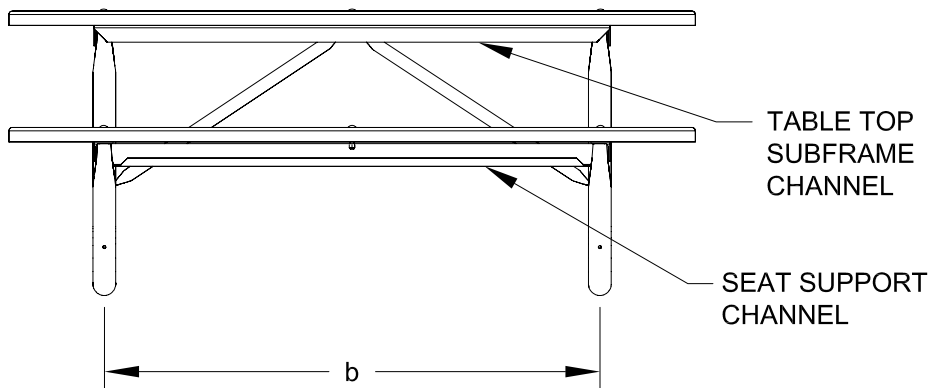

ALL DIMENSIONS IN INCHES

R. J. **THOMAS MFG. Co., Inc.**
P.O. Box 946 • Cherokee, IA 51012

DRAWN BY
WWM

TITLE XT SERIES 6 AND 8 FOOT PORTABLE RECTANGULAR TABLES WITH 100%
RECYCLED PLASTIC TOP AND SEAT PLANKS

DATE 8-20-02

DWG. NO. **AI-1475**