



**Model BTUG-4UP** 4' Bolt Together Portable Rectangular  
Table with Pregalvanized Frame and Untreated Southern  
Yellow Pine Planks

- **Economy of bolt together design**
- **Strong 1-5/8" diameter steel tubing construction**
- **Walk through, nontrip, nontip design**
- **Choice of treated or untreated lumber**
- **Pregalvanized frame components for maintenance-free performance**
- **Diagonal bracing for strength and rigidity**
- **Simple bolt together assembly with all fasteners included**

### **SPECIFICATIONS:**

- **BTUG series** end frames shall be fabricated from 1.660" O.D. (1-5/8" O.D.) pregalvanized steel tubing.
- Table frame design shall incorporate nontip, nontrip, walk-through design features.
- **Model BTUG-4UP** shall be a nom. 4 ft. long.
- **Model BTUG-6UP** shall be a nom. 6 ft. long.
- **Model BTUG-8UP** shall be a nom. 8 ft. long.
- Table tops shall be attached to and supported by 10 ga x 1-3/8" x 2" formed pregalvanized steel angle. Seats shall be attached to and supported by 10 ga x 1-3/4" x 6-1/4" formed pregalvanized steel angle.
- Nominal table height shall be 30". Nominal seat height shall be 18". Length shall be per model number.
- Frames shall be supported by diagonal braces of 1-5/16" O.D. pregalvanized steel pipe.
- All 3/8" dia. galvanized fasteners shall be provided to fasten frames and diagonal braces to lumber.
- **Standard:** Lumber shall be Untreated #1 grade Southern Yellow Pine (denoted by UP in model no.) 2" x 10" nominal sized planks, kiln dried to reduce moisture content. All lumber shall be precision drilled to facilitate assembly and shall have all exposed edges removed to a 3/8" radius.
- **Optional:** Treated #1 Southern Yellow Pine is readily available and shall be pressure treated and kiln dried after treatment (KDAT) to preserve wood against decay. To specify, change UP in model no. to TP; e.g. BTUG-6TP.

### **AVAILABLE OPTIONS**

4, 6', or 8' length  
Treated lumber

**R.J. THOMAS MFG. CO., INC.**

P.O. Box 946 • Cherokee, IA 51012-0946 • PH: 712-225-5115 • 800-762-5002 • FAX: 712-225-5796

E-mail: [pilotrock@rjthomas.com](mailto:pilotrock@rjthomas.com) • Web Site: <http://www.pilotrock.com>

© 2001 R. J. Thomas Mfg. Co., Inc. PILOT ROCK® Park Equipment is a registered trademark of R. J. Thomas Mfg. Co., Inc.

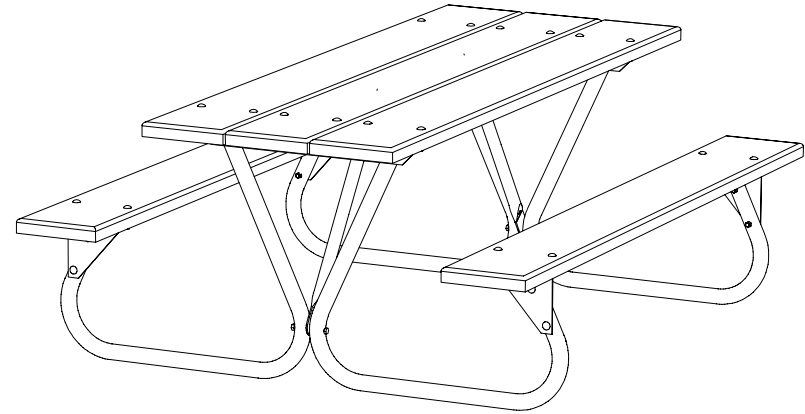
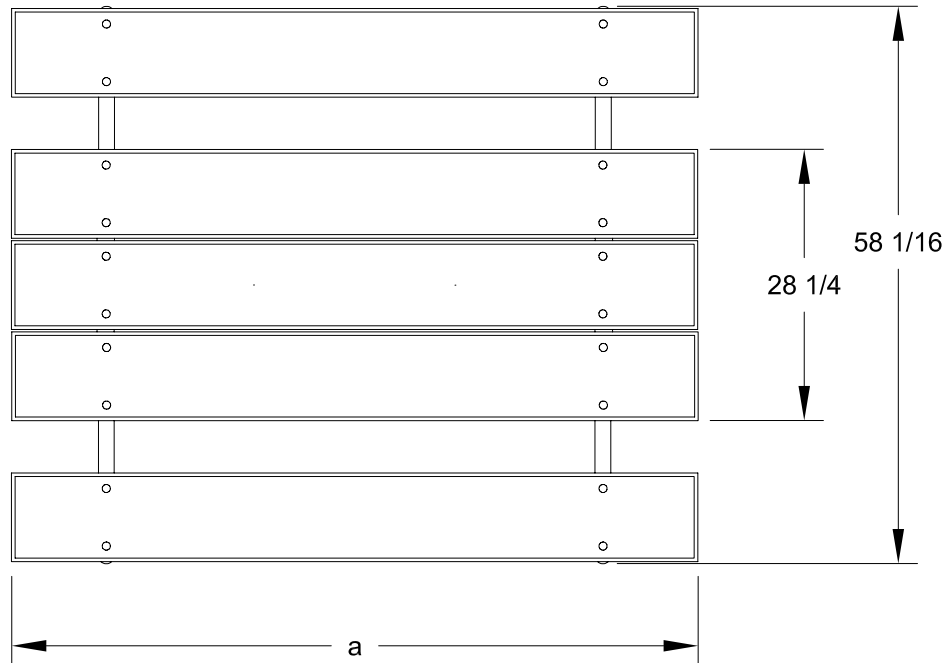

MODEL NUMBER	DIMENSION	
	a	b
BTUG-4	47-1/2	30-1/16
BTUG-6	71-1/2	51-7/8
BTUG-8	95-1/2	70

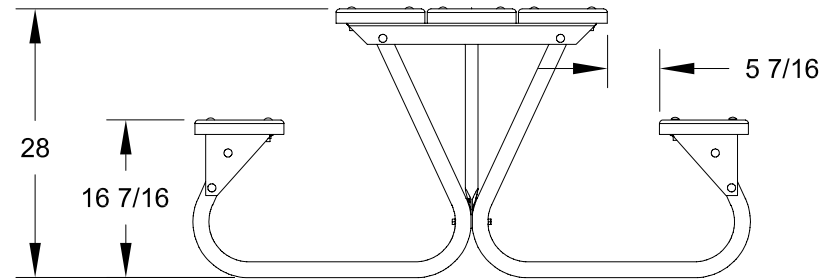
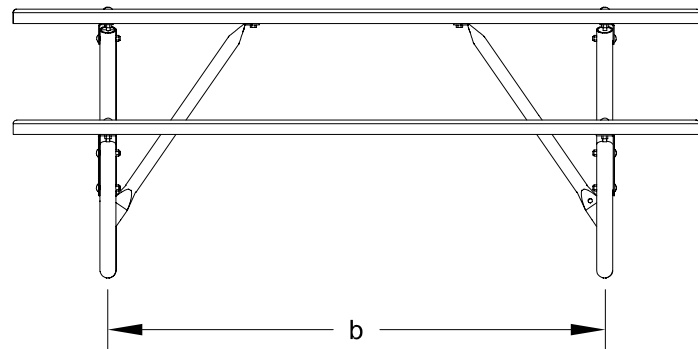

ALL DIMENSIONS IN INCHES

R. J. **THOMAS MFG. Co., Inc.**  
P.O. Box 946 • Cherokee, IA 51012

DRAWN BY  
**WWM**

TITLE MODEL BTUG SERIES 4, 6, AND 8 FOOT BOLT-TOGETHER PORTABLE  
RECTANGULAR TABLE WITH 2" X 10" LUMBER TOP AND SEAT PLANKS

DATE 4-18-05

DWG. NO. **AI-1650**