



Model WXT/CW-8PC 8 Ft. Portable, Universal Rectangular Accessible Table with Brown Powder Coated Frame and Cedar colored 100% Recycled Plastic Planks

- **Nontip, nontrip, walk-through design with wheelchair accessibility at each end**
- **Full capacity seating when wheelchairs are not in place**
- **All welded end frames are fabricated from 2-3/8" diameter steel pipe**
- **Die-formed center channel and diagonal braces align and strengthen entire table**
- **Frames are hot dip galvanized after fabrication for superior corrosion resistance**
- **100% Recycled Plastic Seat and Top Planks with solid color and U.V. stabilizer for ultraviolet protection**
- **Fast, easy assembly using 3/8" dia. galvanized carriage bolts**

AVAILABLE OPTIONS

- **6' or 8' lengths**
- **Black, Green or Brown Powder Coat or Black Enamel Painted steel frame components**
- **Choice of 9 colors of Recycled Plastic**

SPECIFICATIONS:

- **WXT Series** end frames shall be one-piece welded construction, fabricated from 2.375" (2-3/8") O.D. x 10 ga. wall steel pipe to meet 2" nominal steel pipe size specifications with 2" x 2" x 3/16" die-formed steel angle for attaching the seats and tops. Bends shall be tightly formed to prevent tipping when weight is on one side.
- The frame design shall provide the ADA recommended wheelchair clearances under the table top of: 30" wide, 27" high and 24" total knee and toe clearance (19" knee + 5" toe) at each end of the table while maintaining the full seating capacity of the table for common use.
- Table frame design shall incorporate nontip, nontrip, walk-through design features.
- **Model WXT/G-6PC** shall have a nom. 6 ft. length.
- **Model WXT/G-8PC** shall have a nom. 8 ft. length.
- Nominal table height shall be 30". Frame design shall provide a nominal 28" of clearance from ground level to the underside of table. Nominal seat height shall be 18".
- Frames shall be supported by diagonal braces of 1-5/16" O.D. x 14 ga. wall steel pipe that shall connect to a die-formed steel channel designed to align and provide attachment to the table top.
- All 3/8" dia. galvanized carriage bolts and nuts shall be provided to fasten frames to planks.
- **Standard:** Frames, diagonal braces, and center channel shall be hot-dip galvanized after fabrication to ASTM-A123 to maintain an average zinc coating of 2.0 oz. per sq. ft. of surface area (indicated by "/G" in model no.).
- **Standard:** Tops and Seats shall be made of 100% Recycled Plastic molded into 2" x 10" nominal sized planks with solid Cedar color (indicated by "PC" in model no.) formed throughout and a U.V. stabilizer added for ultra-violet protection.
- Recycled Plastic table top and seat planks shall be supported by pregalvanized steel subframe channels.
- **Optional:** Frames shall be finished in Black, Green, or Brown powder coat. To specify, change "/G" in model no. to "/CB" for Black, "/CN" for Green, or "/CW" for Brown, e.g. WXT/CB-6PC.
- **Optional:** Frames, diagonal braces and center channel shall be finished in black enamel paint. To specify, change "/G" to "/B" in model no., e.g. WXT/B-6PC.
- **Optional:** 100% Recycled Plastic planks shall be available in a choice of 8 optional colors. Indicate choice of color by changing "PC" for Cedar color in model no. to: "PA" for Gray; "PW" for Brown; "PN" for Green; "PR" for Red; "PU" for Blue; "PY" for Yellow; "PI" for Ivory; or "PB" for Black; e.g. WXT/G-6PB.

• U.S. Patent Nos. D489,539; D490,992; D493,291; D496,799; D497,262 — Additional U.S. Patents Pending

R.J. THOMAS MFG. CO., INC.

P.O. Box 946 • Cherokee, IA 51012-0946 • PH: 712-225-5115 • 800-762-5002 • FAX: 712-225-5796

E-mail: pilotrock@rjthomas.com • Web Site: <http://www.pilotrock.com>

© 2004 R. J. Thomas Mfg. Co., Inc. PILOT ROCK® Park Equipment is a registered trademark of R. J. Thomas Mfg. Co., Inc.

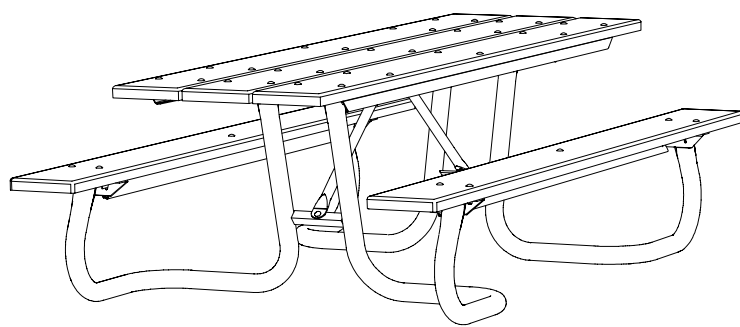
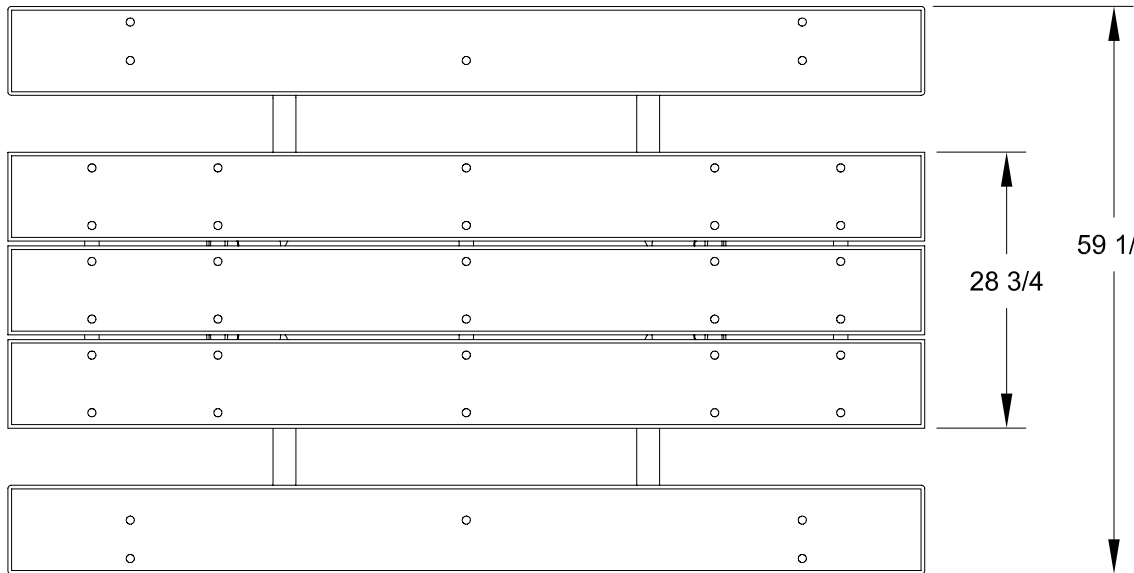

MODEL NUMBER	DIMENSION	
	a	b
WXT-6	71 1/2	19 5/8
WXT-8	95 1/2	37 7/8

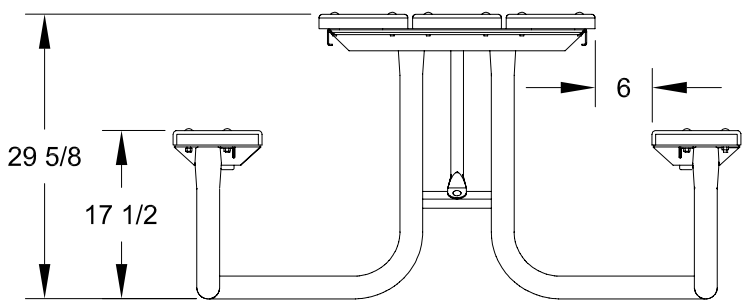
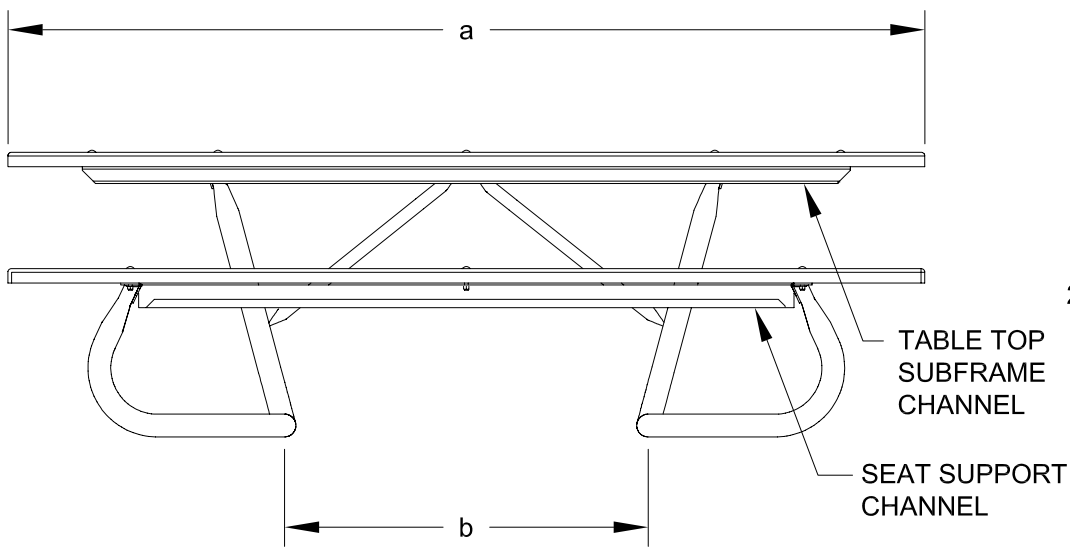

ALL DIMENSIONS IN INCHES

R. J. **THOMAS MFG. Co., Inc.**
 P.O. Box 946 • Cherokee, IA 51012

DRAWN BY
WWM

TITLE **WXT SERIES 6 AND 8 FOOT UNIVERSAL ACCESS TABLES WITH 2" X 10" RECYCLED PLASTIC TOP AND SEAT PLANKS**

DATE **5-10-04**

DWG. NO. **AI-1616**