



*Model UT/G-8PU Portable Rectangular Table
with Hot Dip Galvanized Frames,
8 Ft. long with 2" x 10" Recycled Plastic planks.*

- **Nontip, nontrip, walk-through design**
- **All welded end frames are fabricated from 1-5/8" diameter steel pipe**
- **Die-formed center channel under table top to support and align top planks**
- **Diagonal bracing for strength and rigidity**
- **Frames are hot-dip galvanized after fabrication for superior corrosion resistance**
- **100% Recycled Plastic seat and top planks with solid color and U.V. stabilizer for ultraviolet protection**
- **Steel channel reinforcements under seat and table top planks**
- **Fast, easy assembly using 3/8" dia. galvanized carriage bolts**
- **Limited Lifetime Warranty on frames**

AVAILABLE OPTIONS

6' or 8' models

**Black, Green, or Brown Powder Coated or Black enamel
painted steel frame components**

8 optional colors of Recycled Plastic

SPECIFICATIONS:

- **UT Series** end frames shall be one-piece welded construction, fabricated from 1.660" O.D. x 10 ga. wall steel pipe to meet 1-1/4" nominal pipe size specifications with 2" x 2" x 3/16" A-36 structural grade steel angle for attaching the seats and tops. Bends shall be tightly formed to prevent tipping when weight is on one side.
- Table frame design shall incorporate nontip, nontrip, walk-through design features.
- **Model UT/G-6PC** shall be a nom. 6 ft. in length.
- **Model UT/G-8PC** shall be a nom. 8 ft. in length.
- Nominal table height shall be 30". Frame design shall provide a nominal 28" of clearance from ground level to the underside of table. Nominal seat height shall be 18".
- Frames shall be supported by diagonal braces of 1-5/16" O.D. x 14 ga. wall steel pipe that shall connect to a die-formed steel channel designed to align and provide attachment to the table top.
- All 3/8" dia. galvanized carriage bolts and nuts shall be provided to fasten frames to planks.
- **Standard:** Frames, diagonal braces, and center channel shall be hot-dip galvanized after fabrication to ASTM-A123 to maintain an average zinc coating of 2.0 oz. per sq. ft. of surface area (indicated by "/G" in model no.).
- **Standard:** Top and seats shall be made of 100% Recycled Plastic molded into 2" x 10" nominal sized planks with solid Cedar color (indicated by "PC" in model no.) formed throughout and a U.V. stabilizer added for ultra-violet protection.
- Recycled Plastic table top and seat planks shall be supported by pregalvanized steel subframe channels.
- **Optional:** Frames, diagonal braces and center channel shall be finished in black enamel. (To specify, change "/G" to "/B" in model no., e.g. UT/B-6PC.)
- **Optional:** Frames, diagonal braces and center channel shall be finished in black, brown or green polyester powder coat. (To specify, change "/G" to "/CB" for black, "/CW" for brown, or "/CN" for green in model no., e.g. UT/CB-6PC.)
- **Optional:** 100% Recycled Plastic planks shall be available in a choice of 8 optional colors. Indicate choice of color by changing "PC" for Cedar color in model no. to: "PA" for Gray; "PW" for Brown; "PN" for Green; "PR" for Red; "PU" for Blue; "PY" for Yellow; "PI" for Ivory; or "PB" for Black, (e.g. UT/G-6PB).

R.J. THOMAS MFG. CO., INC.

P.O. Box 946 • Cherokee, IA 51012-0946 • PH: 712-225-5115 • 800-762-5002 • FAX: 712-225-5796

E-mail: pilotrock@rjthomas.com • Web Site: <http://www.pilotrock.com>

© 2004 R. J. Thomas Mfg. Co., Inc. PILOT ROCK® Park Equipment is a registered trademark of R. J. Thomas Mfg. Co., Inc.

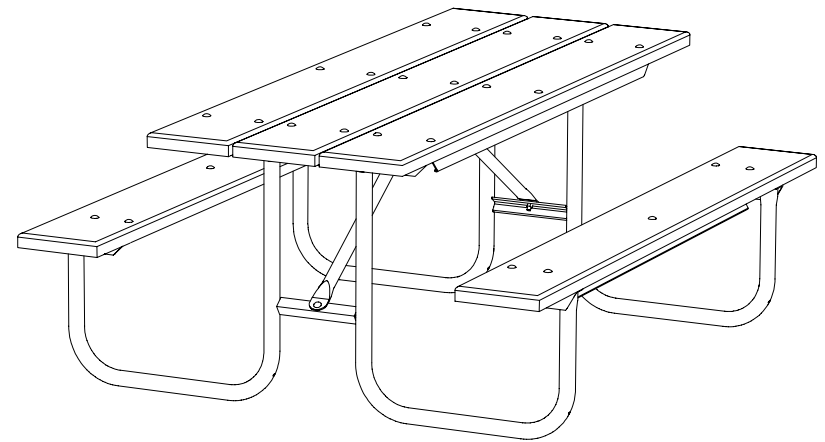
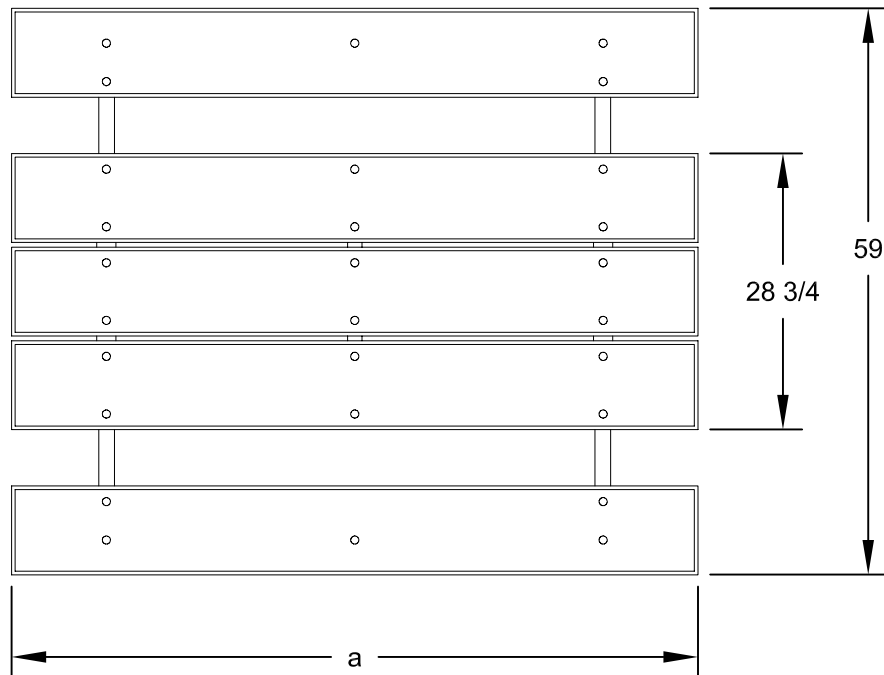

MODEL NUMBER	DIMENSION	
	a	b
UT-6	71-1/2	51-3/4
UT-8	95-1/2	70

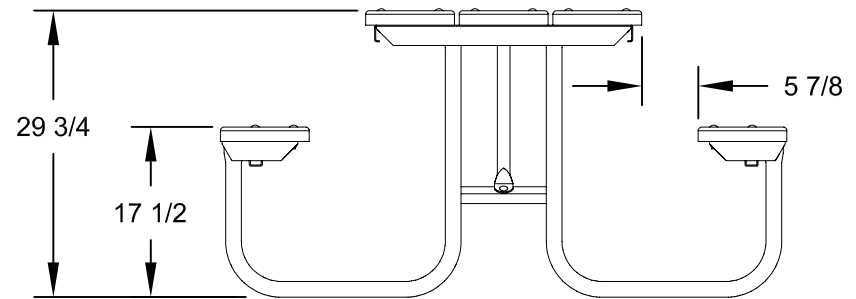
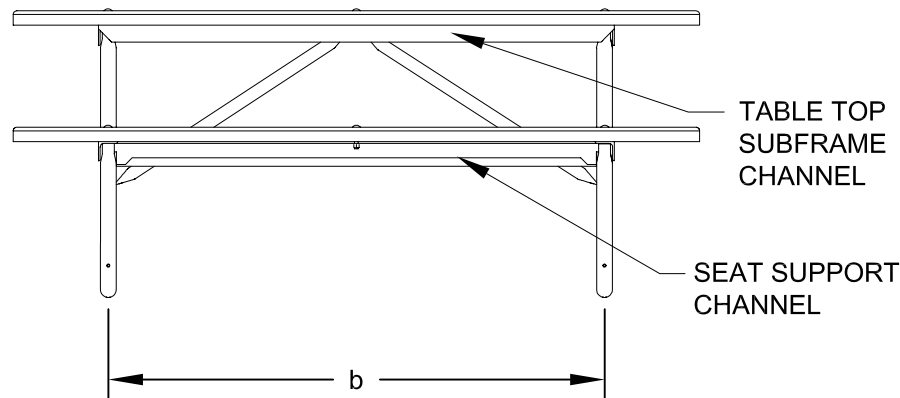

ALL DIMENSIONS IN INCHES

R. J. **THOMAS MFG. Co., Inc.**
P.O. Box 946 • Cherokee, IA 51012

DRAWN BY
WWM

TITLE UT SERIES 6 AND 8 FOOT PORTABLE RECTANGULAR TABLE WITH 100% RECYCLED PLASTIC TOP AND SEAT PLANKS

DATE 12-21-04

DWG. NO. **AI-1622**