



Model WXTH/G-8HN 8 Ft. Raised Top, Portable, Universal Accessible Table with Hot Dip Galvanized Frames, and Green H-Type Plastisol Coated Perforated Steel Top and Seats

- **Raised table top for greater wheelchair clearance**
- **Nontip, nontrip, walk-through design, wheelchair accessibility at each end**
- **Full capacity seating when wheelchairs are not in place**
- **All welded end frames are fabricated from 2-3/8" diameter steel pipe**
- **Diagonal braces align and strengthen entire table**
- **Frames are hot dip galvanized after fabrication for superior corrosion resistance**
- **Plastisol Coating heat fused to Perforated Steel Seats and Top for durability**
- **Fast, easy assembly using 3/8" dia. galvanized carriage bolts**

AVAILABLE OPTIONS

- **6' or 8' lengths**
- **Black, Green or Brown Powder Coated or Black Enamel Painted steel frame components**
- **Plastisol Coated Perforated Steel available in choice of 5 colors)**

SPECIFICATIONS:

- **WXTH Series** end frames shall be one-piece welded construction, fabricated from 2.375" (2-3/8") O.D. x 10 ga. wall steel pipe to meet 2" nominal steel pipe size specifications with 2" x 2" x 3/16" die-formed steel angle for attaching seats and tops. Bends shall be tightly formed to prevent tipping when weight is on one side.
- Frame design shall exceed the ADA recommended wheelchair clearances under the table top of: 30" wide, 27" high and 24" total knee and toe clearance (19" knee + 5" toe) at each end of the table while maintaining full seating capacity of the table.
- Frame design incorporates nontip, nontrip, walk-through features.
- **Model WXTH/G-6HW** shall be a nom. 6 ft. in length.
- **Model WXTH/G-8HW** shall be a nom. 8 ft. in length.
- Nominal table height shall be 33". Frame design shall provide a nominal 31" of clearance from ground level to the underside of table. Nominal seat height shall be 20".
- Frames shall be supported by diagonal braces of 1-5/16" O.D. x 14 ga. wall steel pipe connected to the table top.
- All 3/8" dia. galvanized carriage bolts and nuts shall be provided to fasten frames to top and seats.
- **Standard:** Frames and diagonal braces shall be hot-dip galvanized after fabrication to ASTM-A123 to maintain an average zinc coating of 2.0 oz. per sq. ft. of surface area (indicated by "/G" in model no.).
- **H-Type** table top and seats shall each be one-piece welded construction, fabricated from a 14 ga. perforated steel surface with 9/16" dia. holes in a 13/16" center to center in-line pattern and 2-1/2" x 10 ga. roll-formed vertical edges on all sides reinforced by a 10 ga. die-formed angle substructure. Substructure shall include all mounting holes for easy assembly of table.
- **Standard:** All steel surfaces of the top and seats shall be covered with a 125 mil (1/8") average coating for an overall average thickness, including top and bottom coatings, of 250 mils (1/4") of permanently heat-fused Brown (indicated by "HW" in model number) vinyl Plastisol formulated with high impact additives and UV inhibitors.
- **Optional:** Frames and diagonal braces shall be finished in Black, Green, or Brown powder coat. To specify, change "/G" in model no. to "/CB" for Black, "/CN" for Green, or "/CW" for Brown, e.g. WXTH/CB-6HW.
- **Optional:** Frames and diagonal braces shall be finished in black enamel paint. To specify, change "/G" to "/B" in model no., e.g. WXTH/B-6HW.
- **Optional:** Vinyl Plastisol coating shall be available in a choice of four colors. Indicate choice of color by changing "VW" in model number to; "HR" for Red, "HU" for Blue, "HI" for Ivory, or "HN" for Green; e.g. WXTH/B-6HN.

U.S. Patent Nos. D489,539; D490,992; D493,291; D496,799; D497,262; 6,918,630

R.J. THOMAS MFG. CO., INC.

P.O. Box 946 • Cherokee, IA 51012-0946 • PH: 712-225-5115 • 800-762-5002 • FAX: 712-225-5796

E-mail: pilotrock@rjthomas.com • Web Site: <http://www.pilotrock.com>

© 2005 R. J. Thomas Mfg. Co., Inc. PILOT ROCK® Park Equipment is a registered trademark of R. J. Thomas Mfg. Co., Inc.

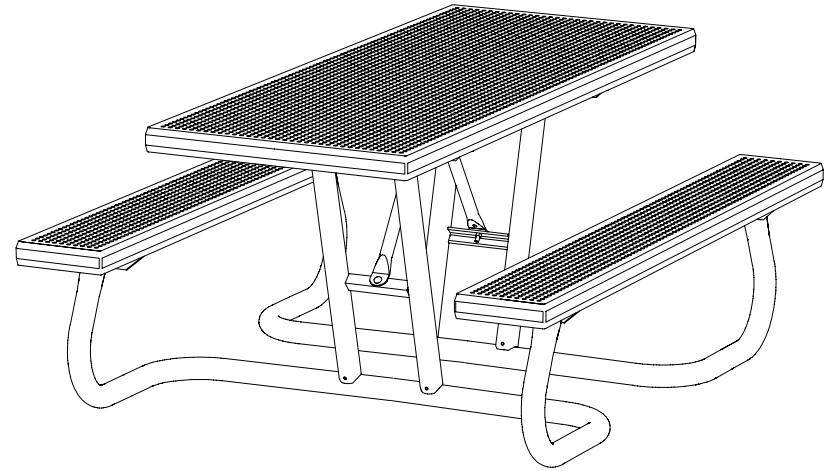
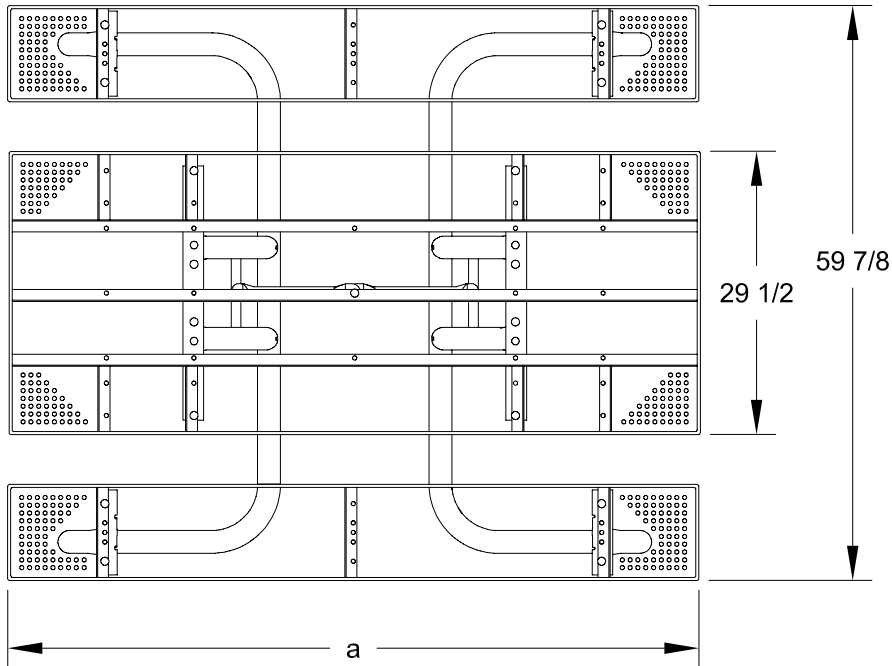

MODEL NUMBER	DIMENSION	
	a	b
WXTH-6	72	18
WXTH-8	96	36-1/4

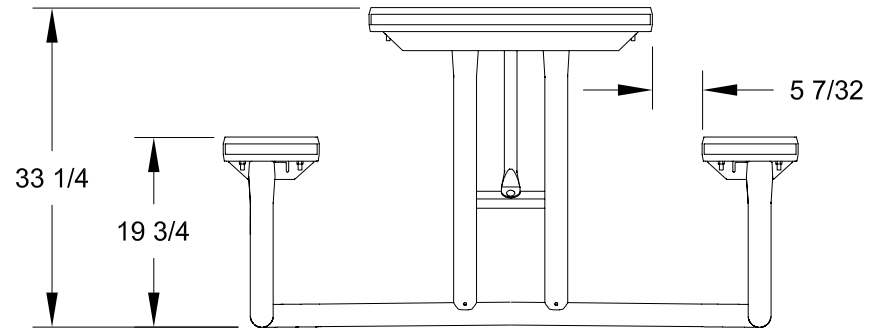
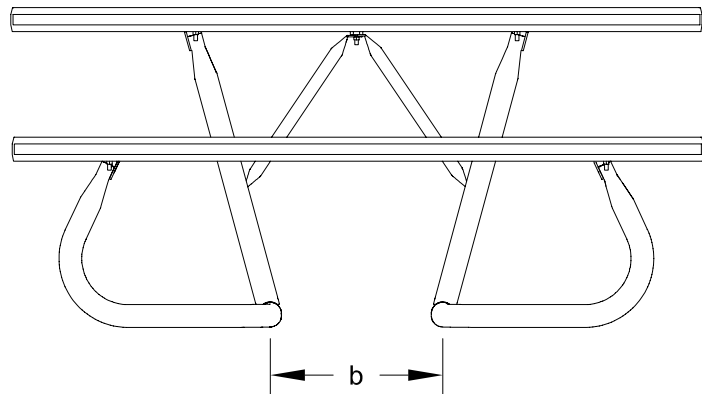

ALL DIMENSIONS IN INCHES

R. J. **THOMAS MFG. Co., INC.**
P.O. Box 946 • Cherokee, IA 51012

DRAWN BY
WWM

TITLE **WXTH SERIES 6 AND 8 FOOT RAISED TOP UNIVERSAL ACCESS TABLE
WITH H-TYPE PLASTISOL COATED PERFORATED STEEL TOP AND SEATS**

DATE **04-12-06**

DWG. NO. **AI-1648**