



(Above) Model LH/G-1/A Lantern Holder with galvanized finish and Optional Wheelchair Accessible hook.
 (Left) Model LH/G-1 Lantern Holder with galvanized finish.

SPECIFICATIONS:

- **Model LH-1** Series lantern holders shall be constructed of 2-3/8" OD x 11 ga. wall tube with a 90 degree radius bend forming a overhang to provide clearance for campsite lighting devices to hang from an open hook made of 1/2" dia. round steel rod.
- Lantern holder is designed to be anchored 28" into a concrete footing which places the lantern hook 76" above ground surface.
- **Standard:** Lantern holder shall be hot dip galvanized after fabrication to ASTM-A123 to maintain an average zinc coating of 2.0 oz. per sq. ft. of surface area (indicated by "/G" in model no.).
- **Optional:** Lantern holder shall be finished in black enamel paint. To specify, change "/G" to "/B" in model no., e.g. LH/B-1.
- **Optional:** An additional wheelchair accessible hook (indicated by "/A" in model no.) shall be welded to the lantern holder before galvanizing, extending from the pole 54" above ground surface level to provide a handicap accessible position for hanging campsite lighting devices. Model no. becomes LH/G-1/A.
- **Optional Rules Plate:** A hot dip galvanized, 6" x 12" x 7 ga. steel plate with screws for attachment to lantern holder pole shall provide a surface for attachment of decals or adhesive signs posting park regulations, notices, and fees. Add "/RP" to end of model no. e.g. LH/G-1/RP.
- **Optional Shelf:** A one-piece welded 14" x 20" x 10 ga. utility shelf with reinforcing gussets and a "U" clamp for attachment to the lantern holder pole shall be available. All galvanized 3/8" fasteners shall be included. To order with on a new lantern holder, add "/S" to the end of model no., e.g. LH/G-1/S or LH/G-1/A/S. To order only the shelf to retro fit to an existing 2-3/8" OD round tube pole, order **Model LHS/G-1**.
- **Optional:** Color choices of powder coated finish for lantern holder and optional accessories. For optional colors choices see Specification Bulletin # SPC-CO-001.

- **Heavy 2-3/8" diameter 11 ga. wall steel tubing**
- **1/2" diameter steel hook**
- **Hot dip galvanized finish**
- **Accessible model available**
- **Optional Utility Shelf**
- **Optional Rules Plate**

AVAILABLE OPTIONS

Black enamel painted finish

Optional
 Bolt-on
 Rules Plate



Optional
 Bolt-on
 Utility Shelf



R.J. THOMAS MFG. CO., INC.

P.O. Box 946 • Cherokee, IA 51012-0946 • PH: 712-225-5115 • 800-762-5002 • FAX: 712-225-5796

E-mail: pilotrock@rjthomas.com • Web Site: <http://www.pilotrock.com>

© 2006 R. J. Thomas Mfg. Co., Inc. PILOT ROCK® Park Equipment is a registered trademark of R. J. Thomas Mfg. Co., Inc.

MODEL
LH/G-1

MODEL
LH/G-1/A

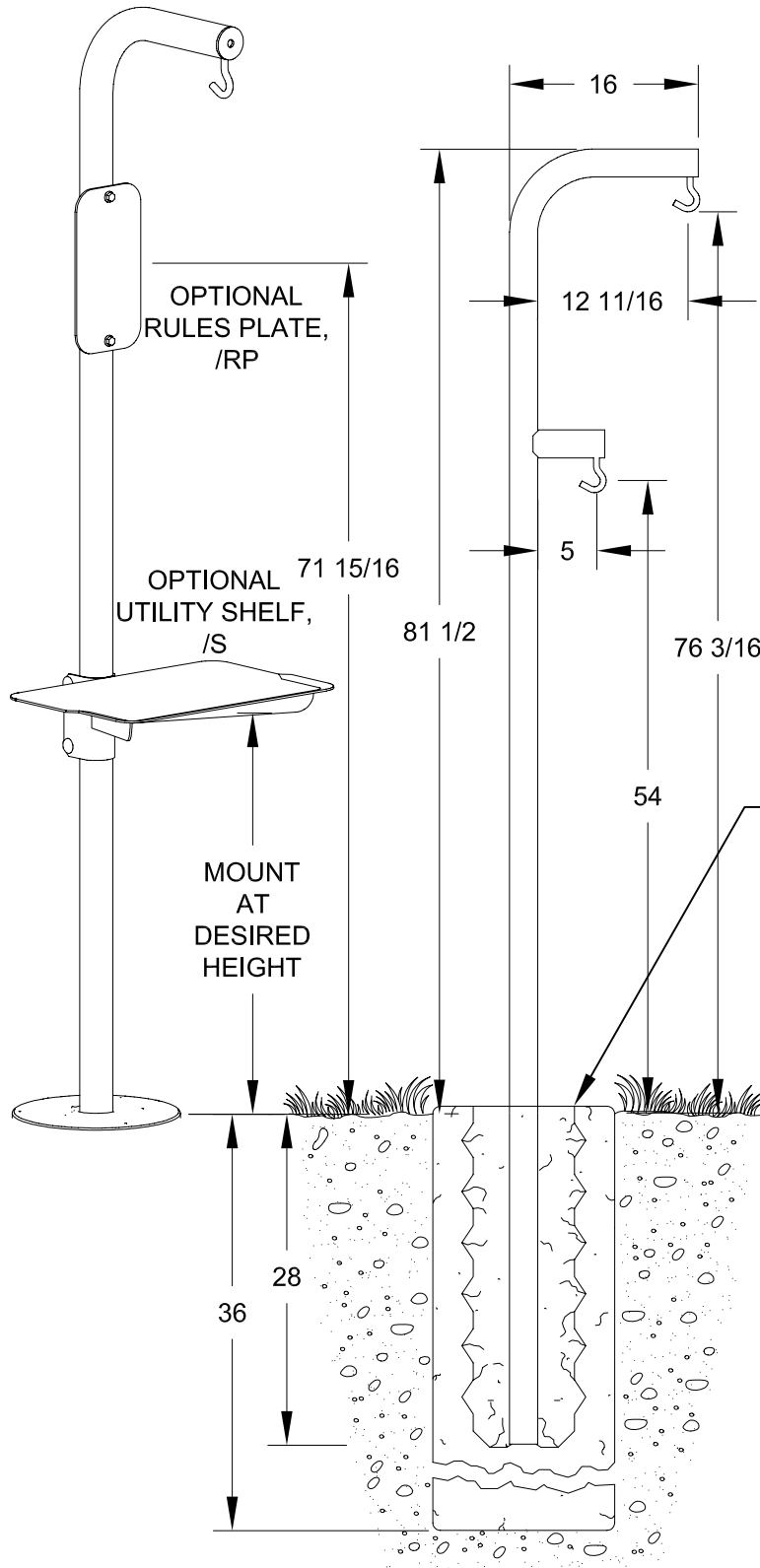

12" DIA.
MIN.
NOTE:
LOCAL SOIL
CONDITIONS
MAY REQUIRE
A LARGER
FOOTING
(CHECK LOCAL
CODES)

ALL DIMENSIONS IN INCHES

R.J. **THOMAS MFG.**
Co., Inc.
P.O. Box 946
Cherokee, IA 51012

TITLE MODEL LH-1 SERIES LANTERN HOLDERS. LH-1 SHOWN WITH
OPTIONAL UTILITY SHELF AND RULES PLATE. MODEL LH-1/A
WHEEL CHAIR ACCESSIBLE LANTERN HOLDER ALSO SHOWN

DRAWN BY **WWM**

DATE 10-31-06

DWG. NO. **AI-1742**