



*Model B42/CB-4IB34 4 Ft. Surface Mount Bench  
with Black Powder Coat Frames  
and Indonesian Balau Wood 3" x 4" Timbers.*

- **Comfortable contoured full back and seat design**
- **Design offers extensions to make longer benches with additional armrests**
- **Stylish armrest loops integrated into end frames**
- **Sturdy, formed and welded steel frame construction**
- **Powder Coat frame finish**
- **Precision drilled Hardwood 3" x 4" Timbers**
- **Quality construction throughout**

#### **AVAILABLE OPTIONS**

- 3', 4', or 6' models
- Choice of colors of Powder Coat Finish on steel frame components
- Treated #1 Southern Yellow Pine or Construction Heart Redwood lumber
- Bench Extensions for 3' and 4' benches
- Custom Lettering and Plaques available (call for details)

### **3, 4, and 6 Ft. Models**

#### **SPECIFICATIONS:**

- **Model B42-3** shall be a nom. 3 ft. in length.
- **Model B42-4** shall be a nom. 4 ft. in length.
- **Model B42-6** shall be a nom. 6 ft. in length.
- **Model B42** end frames shall be one-piece welded construction with frame leg and foot to meet 1-1/2" nominal steel pipe size specifications (1-7/8" O.D.). Frame foot shall be die-formed with flattened and rounded ends, with a 9/16" dia. anchor hole in each end. Back and seat bracket shall be constructed of 2-3/8" x 1-1/2" x 1/8" nominal sized, die-formed channel, with holes to mount eight 3" x 4" timbers. The end frames shall include a welded-on circular armrest formed from 1.66" O.D. steel tubing.
- Benches shall be permanently surface mounted using 9/16" dia. holes provided in each frame foot for use with concrete anchors (anchors not included).
- **Standard:** Frames shall be finished in Black powder coat (indicated by "/CB" in model no.).
- **Standard:** Lumber shall be Indonesian Balau Wood 3" x 4" nominal sized timbers (indicated by "IB" in model no.). All timbers shall be precision drilled for fast, easy assembly and shall have all exposed edges removed to a 3/8" radius with a bullnose profile timber used on top and front positions.
- All 3/8" dia. galvanized carriage bolts and nuts shall be provided to fasten frames to lumber.
- **Optional:** Color choices of powder coated steel frame components. For optional colors choices see Specification Bulletin # SPC-CO-001.
- **Optional:** Lumber shall be #1 grade Southern Yellow Pine, pressure treated and kiln dried after treatment (KDAT) to preserve wood against decay, or Construction Heart Redwood. (To specify, change "IB" in model no. to "TP" for Treated Pine, e.g. B42/CB-3TP34, or to "CO" for Construction Heart Redwood, e.g. B42/CB-3CO34.)
- Bench extensions of a matching design shall be available on 3 and 4 ft. bench models. For additional information please refer to Specification Bulletin #SPC-BC-041.

**R.J. THOMAS MFG. CO., INC.**

**P.O. Box 946 • Cherokee, IA 51012-0946 • PH: 712-225-5115 • 800-762-5002 • FAX: 712-225-5796**

**E-mail: [pilotrock@rjthomas.com](mailto:pilotrock@rjthomas.com) • Web Site: <http://www.pilotrock.com>**

© 2004 R. J. Thomas Mfg. Co., Inc. PILOT ROCK® Park Equipment is a registered trademark of R. J. Thomas Mfg. Co., Inc.

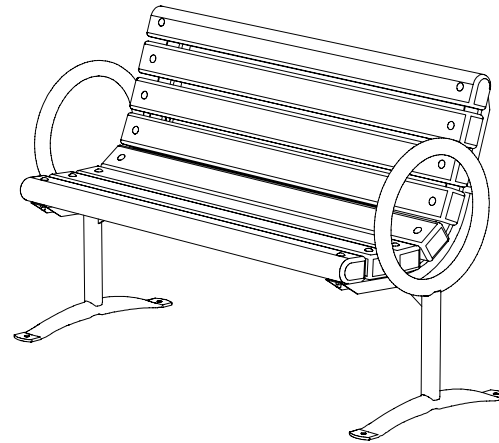
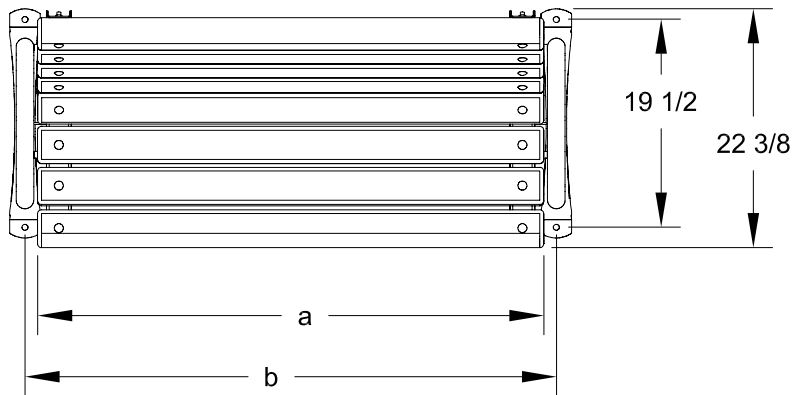

MODEL NUMBER	DIMENSION		
	a	b	c
B42-3	35 1/2	37 7/8	40 3/4
B42-4	47 1/2	49 7/8	52 3/4
B42-6	71 1/2	73 7/8	76 3/4

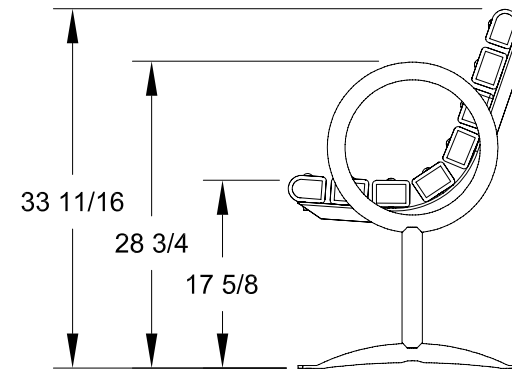
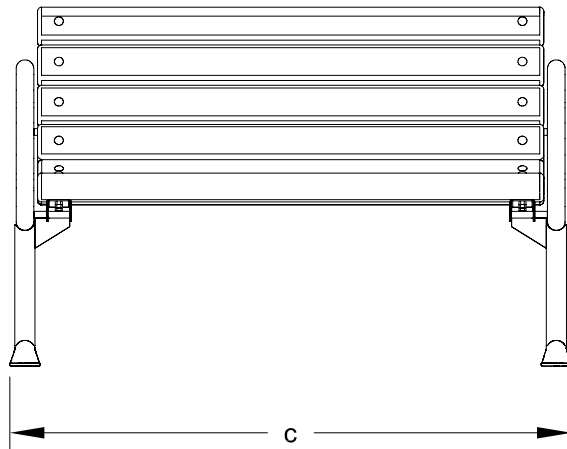

ALL DIMENSIONS IN INCHES

R. J. **THOMAS MFG. Co., INC.**  
P.O. Box 946 • Cherokee, IA 51012

DRAWN BY  
**WWM**

TITLE **SIVER SIOUX SERIES MODEL B42 3, 4, AND 6 FOOT CONTOUR SURFACE MOUNT BENCHES WITH 3" X 4" LUMBER TIMBERS**

DATE 1-14-04

DWG. NO. **AI-1532**