



Model BE42/CB-3IB34 3 Ft. Surface Mount Bench Extension
with Black Powder Coat Frames
and Indonesian Balau Wood 3" x 4" Timbers.
(Shown with Model B42/CB-3IB4 Bench.)

- **Comfortable contoured full back and seat design**
- **Designed to join easily with Model B42 benches to make longer benches with additional armrests**
- **Stylish armrest loops integrated into extension frames**
- **Sturdy, formed and welded steel frame construction**
- **Powder Coat frame finish**
- **Precision drilled Hardwood 3" x 4" Timbers**
- **Quality construction throughout**

AVAILABLE OPTIONS

- 3' or 4' models
- Choice of colors of Powder Coat Finish on steel frame components
- Treated #1 Southern Yellow Pine or Construction Heart Redwood lumber
- Custom Lettering and Plaques available (call for details)

3 and 4 Ft. Models

SPECIFICATIONS:

- **Model BE42-3** shall be a nom. 3 ft. in length.
- **Model BE42-4** shall be a nom. 4 ft. in length.
- **Model BE42** bench extensions shall be used with Model B42 3 and 4 ft. benches. Multiple extensions can be added to create any length of bench in 3 and 4 ft. increments. The extension frame replaces one bench end frame which is then moved to the end of the extension. (For information on Model B42 benches refer to Specification Bulletin SPC-BC-037.)
- **Model BE42** extension frame shall be one-piece welded construction with 3/8" x 2-1/2" A-36 flat steel bar legs and die-formed feet with 9/16" dia. anchor holes. Two back and seat brackets shall be constructed of 3/8" x 2-1/2" A-36 flat steel bar, die-formed for shape and reinforcement, with holes to mount eight 3" x 4" timbers. The extension frame shall include a welded-on circular armrest formed from 1.66" O.D. steel tubing.
- Extensions shall be permanently surface mounted using 9/16" dia. holes provided in each frame foot for use with concrete anchors (anchors not included).
- **Standard:** Frames shall be finished in Black powder coat (indicated by "/CB" in model no.).
- **Standard:** Lumber shall be Indonesian Balau Wood 3" x 4" nominal sized timbers (indicated by "IB" in model no.). All timbers shall be precision drilled for fast, easy assembly and shall have all exposed edges removed to a 3/8" radius with a bullnose profile timber used on top and front positions.
- All 3/8" dia. galvanized carriage bolts and nuts shall be provided to fasten frames to lumber.
- **Optional:** Color choices of powder coated steel frame components. For optional colors choices see Specification Bulletin # SPC-CO-001.
- **Optional:** Lumber shall be #1 grade Southern Yellow Pine, pressure treated and kiln dried after treatment (KDAT) to preserve wood against decay, or Construction Heart Redwood. (To specify, change "IB" in model no. to "TP" for Treated Pine, e.g. BE42/CB-3TP34, or to "CO" for Construction Heart Redwood, e.g. BE42/CB-3CO34).

R.J. THOMAS MFG. CO., INC.

P.O. Box 946 • Cherokee, IA 51012-0946 • PH: 712-225-5115 • 800-762-5002 • FAX: 712-225-5796

E-mail: pilotrock@rjthomas.com • Web Site: <http://www.pilotrock.com>

© 2004 R. J. Thomas Mfg. Co., Inc. PILOT ROCK® Park Equipment is a registered trademark of R. J. Thomas Mfg. Co., Inc.

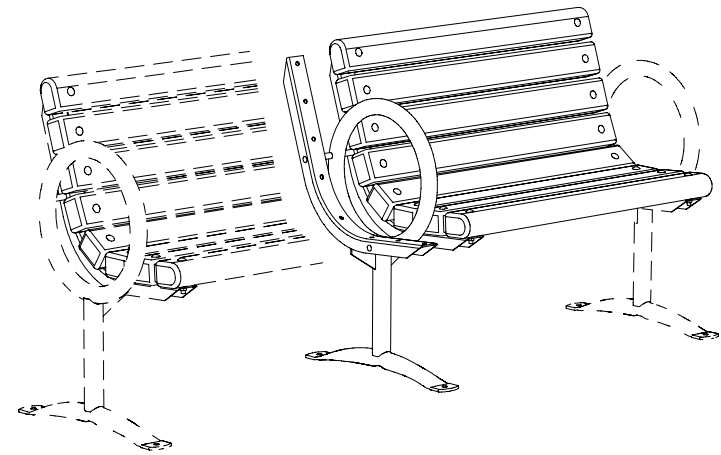
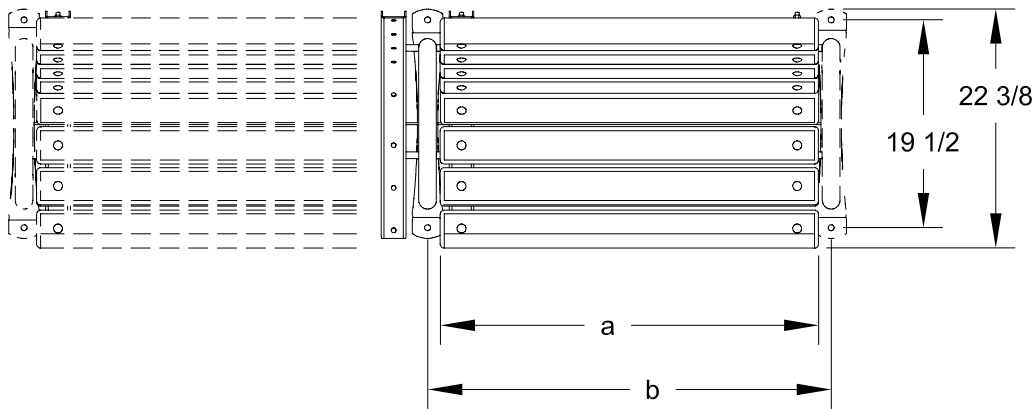

MODEL NUMBER	DIMENSION		
	a	b	c
BE42-3	35 1/2	37 7/8	37 7/8
BE42-4	47 1/2	49 7/8	49 7/8

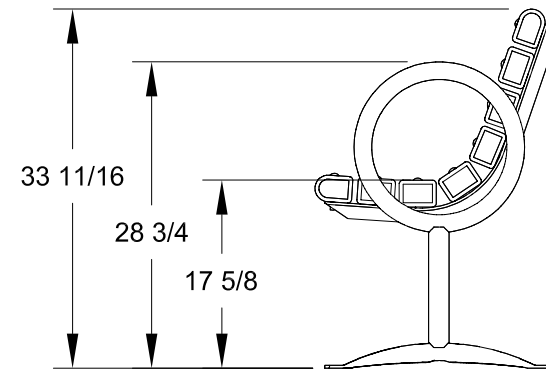
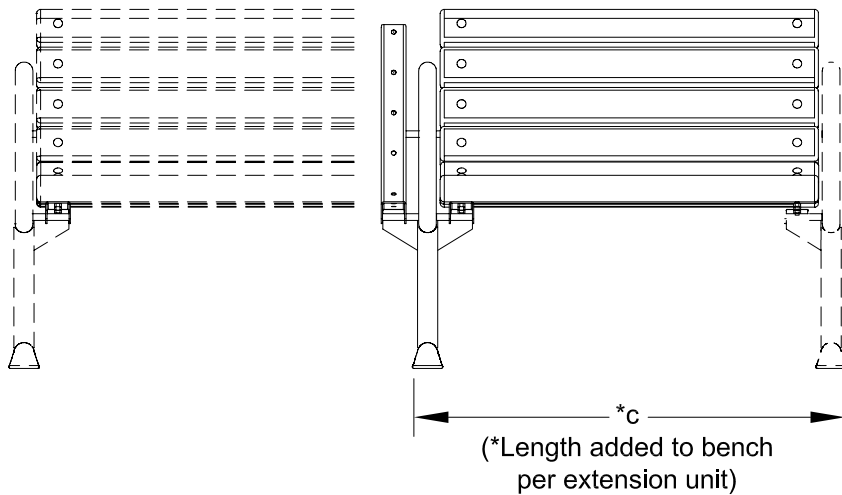

ALL DIMENSIONS IN INCHES

R. J. **THOMAS MFG. CO., INC.**
P.O. Box 946 • Cherokee, IA 51012

DRAWN BY
WWM

TITLE SILVER SIOUX SERIES MODEL BE42 3 AND 4 FOOT CONTOUR SURFACE MOUNT
BENCH EXTENSION WITH 3" X 4" LUMBER TIMBERS

DATE 1-15-04

DWG. NO. **AI-1537**