



*Model B63/CB-4IB34 Embedded Mount Bench
with Black Powder Coat Frames,
4 Ft. long with Indonesian Balau Wood 3" x 4" Timbers.*

- **Comfortable contoured full back and seat design**
- **Design offers extensions to make longer benches with additional armrests**
- **Wide curves at the corners of the frames also serve as comfortable armrests**
- **Sturdy, formed and welded steel frame construction**
- **Powder Coat frame finish**
- **Precision drilled Hardwood 3" x 4" Timbers**
- **Quality construction throughout**

3, 4, and 6 Ft. Models

SPECIFICATIONS:

- **Model B63-3** shall be a nom. 3 ft. in length.
- **Model B63-4** shall be a nom. 4 ft. in length.
- **Model B63-6** shall be a nom. 6 ft. in length.
- **Model B63** end frames shall be one-piece welded construction with frame to meet 2" nominal steel pipe size specifications (2-3/8" O.D.) with each corner to be formed on a nominal 6" centerline radius. Back and seat bracket shall be constructed of 2-3/8" x 1-1/2" x 1/8" nominal sized, die-formed channel, with holes to mount eight 3" x 4" timbers.
- Benches shall be permanently anchored by embedding bench legs in concrete footings.
- **Standard:** Frames shall be finished in Black powder coat (indicated by "/CB" in model no.).
- **Standard:** Lumber shall be Indonesian Balau Wood 3" x 4" nominal sized timbers (indicated by "IB" in model no.). All timbers shall be precision drilled for fast, easy assembly and shall have all exposed edges removed to a 3/8" radius with a bullnose profile timber used on top and front positions.
- All 3/8" dia. galvanized carriage bolts and nuts shall be provided to fasten frames to lumber.
- **Optional:** Color choices of powder coated steel frame components. For optional colors choices see Specification Bulletin # SPC-CO-001.
- **Optional:** Lumber shall be #1 grade Southern Yellow Pine, pressure treated and kiln dried after treatment (KDAT) to preserve wood against decay, or Construction Heart Redwood. (To specify, change "IB" in model no. to "TP" for Treated Pine, e.g. B63/CB-3TP34, or to "CO" for Construction Heart Redwood, e.g. B63/CB-3CO34.)
- Bench extensions of a matching design shall be available on 3 and 4 ft. bench models. For additional information please refer to Specification Bulletin #SPC-BC-087.

AVAILABLE OPTIONS

- 3', 4', or 6' models
- Choice of colors of Powder Coat Finish on steel frame components
- Treated #1 Southern Yellow Pine or Construction Heart Redwood lumber
- Bench Extensions for 3' and 4' benches
- Custom Lettering and Plaques available (call for details)

R.J. THOMAS MFG. CO., INC.

P.O. Box 946 • Cherokee, IA 51012-0946 • PH: 712-225-5115 • 800-762-5002 • FAX: 712-225-5796

E-mail: pilotrock@rjthomas.com • Web Site: <http://www.pilotrock.com>

© 2004 R. J. Thomas Mfg. Co., Inc. PILOT ROCK® Park Equipment is a registered trademark of R. J. Thomas Mfg. Co., Inc.

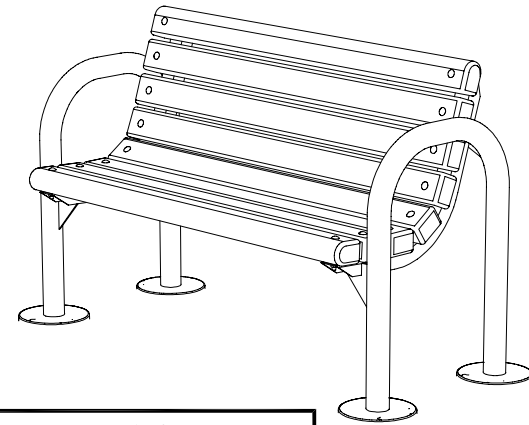
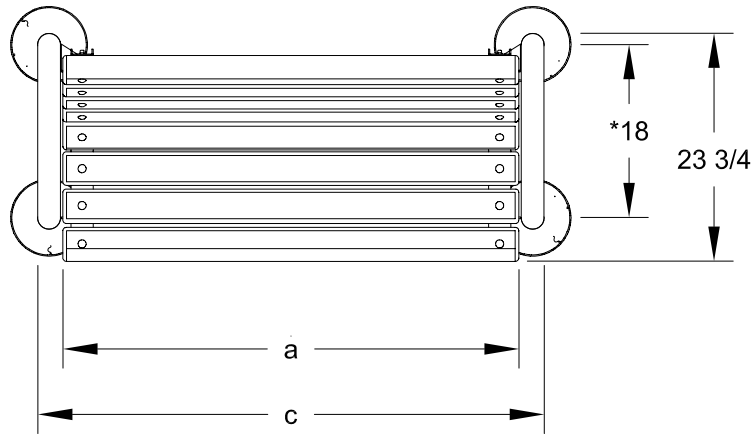

MODEL NUMBER	DIMENSION		
	a	*b	c
B63-3	35 1/2	38 3/8	40 3/4
B63-4	47 1/2	50 3/8	52 3/4
B63-6	71 1/2	74 3/8	76 3/4

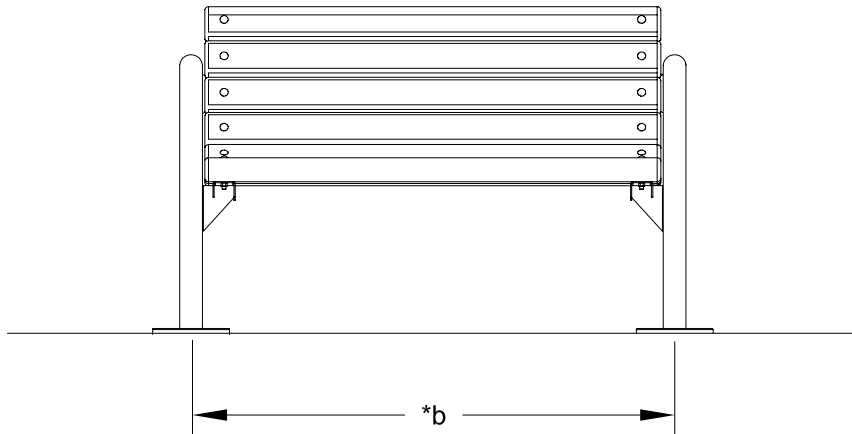

*CTR TO CTR
OF FRAME POSTS

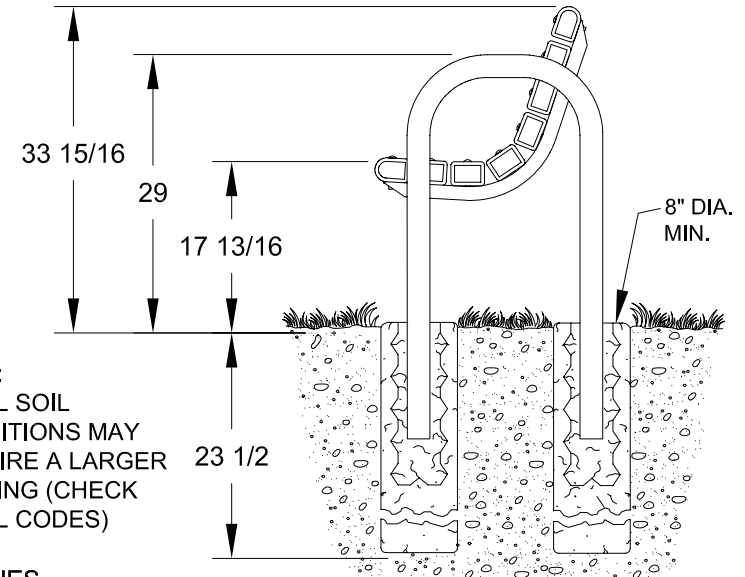

NOTE:
LOCAL SOIL
CONDITIONS MAY
REQUIRE A LARGER
FOOTING (CHECK
LOCAL CODES)

ALL DIMENSIONS IN INCHES

R. J. **THOMAS MFG. Co., INC.**
P.O. Box 946 • Cherokee, IA 51012

DRAWN BY
WWM

TITLE RIVERVIEW SERIES MODEL B63 3, 4, AND 6 FOOT CONTOUR EMBEDDED MOUNT
BENCH WITH 3" X 4" LUMBER TIMBERS

DATE 3-19-04

DWG. NO. **AI-1604**