



*Model BE64/CW-3IB34 Surface Mount Bench Extension
with Brown Powder Coat Frames,
3 Ft. long with Indonesian Balau Wood 3" x 4" Timbers.
(Shown with Model B64/CW-3IB34 Bench.)*

- **Comfortable contoured full back and seat design may be accessed from either side**
- **Designed to join easily with Model B64 benches to make longer benches with additional armrests**
- **Wide curves at the corners of the frames also serve as comfortable armrests**
- **Sturdy, formed and welded steel frame construction**
- **Powder Coat frame finish**
- **Precision drilled Hardwood 3" x 4" Timbers**
- **Quality construction throughout**

AVAILABLE OPTIONS

- 3' or 4' models
- Choice of colors of Powder Coat Finish on steel frame components
- Treated #1 Southern Yellow Pine or Construction Heart Redwood lumber
- Custom Lettering and Plaques available (call for details)

3 and 4 Ft. Models

SPECIFICATIONS:

- **Model BE64-3** shall be a nom. 3 ft. in length.
- **Model BE64-4** shall be a nom. 4 ft. in length.
- **Model BE64** bench extensions shall be used with Model B64 3 and 4 ft. benches. Multiple extensions can be added to create any length of bench in 3 and 4 ft. increments. The extension frame replaces one bench end frame which is then moved to the end of the extension. (For information on Model B64 benches refer to Specification Bulletin SPC-BC-089.)
- **Model BE64** extension frames shall be one-piece welded construction with frame to meet 2" nominal steel pipe size specifications (2-3/8" O.D.) and each corner to be formed on a nominal 6" centerline radius. Two back and seat brackets shall be constructed of 2-3/8" x 1-1/2" x 1/8" nominal sized, die-formed channel, with holes to mount a total of (16) 3" x 4" timbers, and welded in a back-to-back configuration.
- Benches shall be permanently surface mounted using 9/16" dia. holes provided in each base plate for use with concrete anchors (anchors not included).
- **Standard:** Frames shall be finished in Black powder coat (indicated by "/CB" in model no.).
- **Standard:** Lumber shall be Indonesian Balau Wood 3" x 4" nominal sized timbers (indicated by "IB" in model no.). All timbers shall be precision drilled for fast, easy assembly and shall have all exposed edges removed to a 3/8" radius with a bullnose profile timber used on top and front positions.
- All 3/8" dia. galvanized carriage bolts and nuts shall be provided to fasten frames to lumber.
- **Optional:** Color choices of powder coated steel frame components. For optional colors choices see Specification Bulletin # SPC-CO-001.
- **Optional:** Lumber shall be #1 grade Southern Yellow Pine, pressure treated and kiln dried after treatment (KDAT) to preserve wood against decay, or Construction Heart Redwood. (To specify, change "IB" in model no. to "TP" for Treated Pine, e.g. BE64/CB-3TP34, or to "CO" for Construction Heart Redwood, e.g. BE64/CB-3CO34).

R.J. THOMAS MFG. CO., INC.

P.O. Box 946 • Cherokee, IA 51012-0946 • PH: 712-225-5115 • 800-762-5002 • FAX: 712-225-5796

E-mail: pilotrock@rjthomas.com • Web Site: <http://www.pilotrock.com>

© 2004 R. J. Thomas Mfg. Co., Inc. PILOT ROCK® Park Equipment is a registered trademark of R. J. Thomas Mfg. Co., Inc.

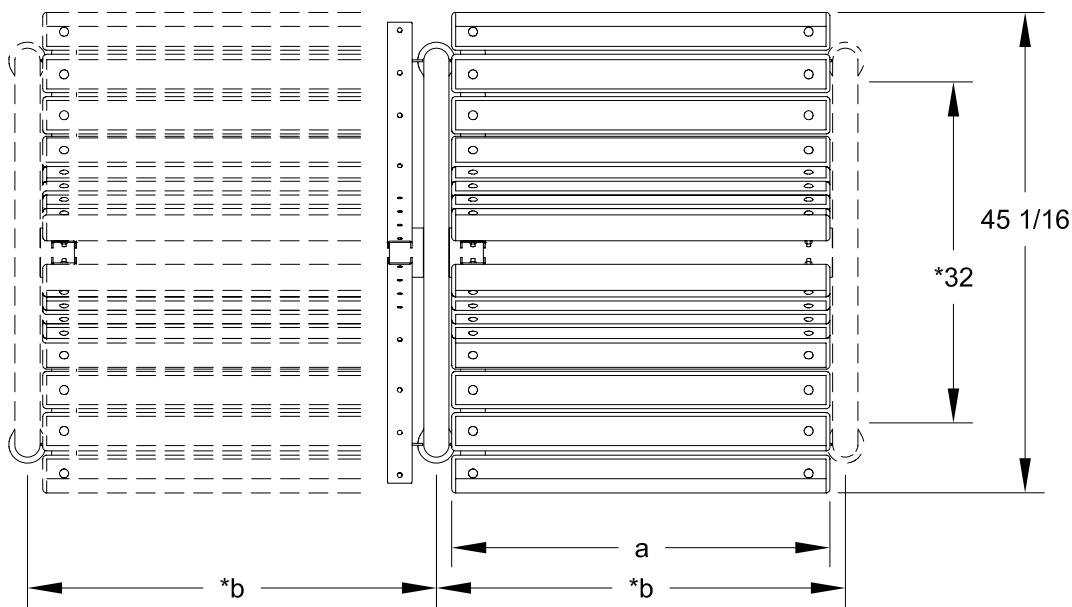

*CTR TO CTR OF MOUNTING HOLES

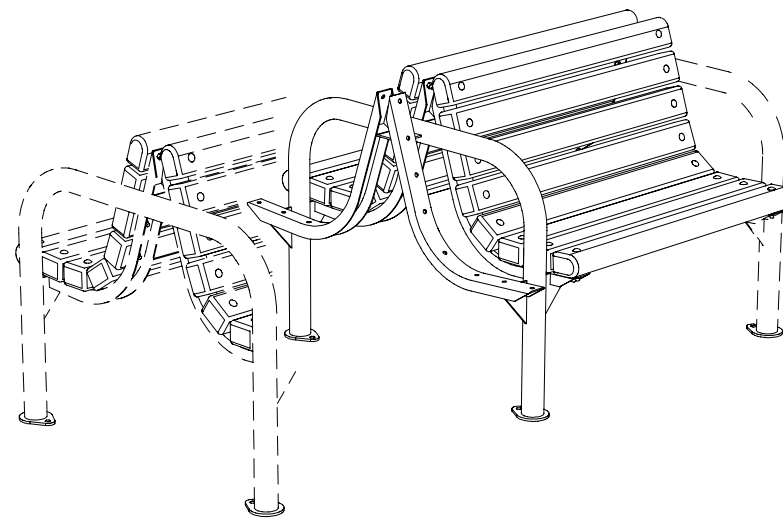

MODEL NUMBER	DIMENSION		
	a	*b	c
BE64-3	35 1/2	38 3/8	38 3/8
BE64-4	47 1/2	50 3/8	50 3/8

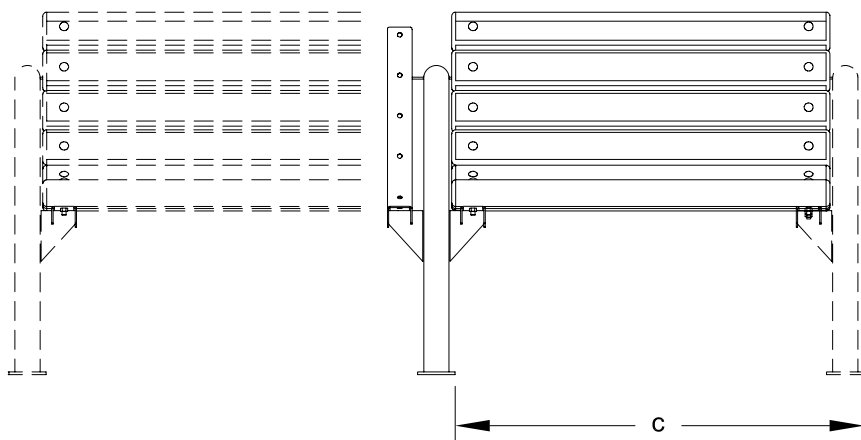

(Length added to bench per extension unit)

ALL DIMENSIONS IN INCHES

R. J. **THOMAS MFG. CO., INC.**
P.O. Box 946 • Cherokee, IA 51012

DRAWN BY
WWM

TITLE RIVERVIEW SERIES MODEL BE64 3 AND 4 FOOT BACK TO BACK CONTOUR
SURFACE MOUNT BENCH EXTENSIONS WITH 3" X 4" LUMBER TIMBERS (SHOWN
WITH RIVERVIEW SERIES MODEL B64 BENCH IN PHANTOM)

DATE 2-16-04

DWG. NO. **AI-1563**