



*Model BE65/CN-3IB34 Embedded Mount Bench Extension
with Green Powder Coat Frames,
3 Ft. long with Indonesian Balau Wood 3" x 4" Timbers.
(Shown with Model B65/CN-3IB34 Bench.)*

- **Comfortable contoured full back and seat design may be accessed from either side**
- **Designed to join easily with Model B65 benches to make longer benches with additional armrests**
- **Wide curves at the corners of the frames also serve as comfortable armrests**
- **Sturdy, formed and welded steel frame construction**
- **Powder Coat frame finish**
- **Precision drilled Hardwood 3" x 4" Timbers**
- **Quality construction throughout**

AVAILABLE OPTIONS

- 3' or 4' models
- Choice of colors of Powder Coat Finish on steel frame components
- Treated #1 Southern Yellow Pine or Construction Heart Redwood lumber
- Custom Lettering and Plaques available (call for details)

3 and 4 Ft. Models

SPECIFICATIONS:

- **Model BE65-3** shall be a nom. 3 ft. in length.
- **Model BE65-4** shall be a nom. 4 ft. in length.
- **Model BE65** bench extensions shall be used with Model B65 3 and 4 ft. benches. Multiple extensions can be added to create any length of bench in 3 and 4 ft. increments. The extension frame replaces one bench end frame which is then moved to the end of the extension. (For information on Model B65 benches refer to Specification Bulletin SPC-BC-093.)
- **Model BE65** extension frames shall be one-piece welded construction with frame to meet 2" nominal steel pipe size specifications (2-3/8" O.D.) with each corner to be formed on a nominal 6" centerline radius. Two back and seat brackets shall be constructed of 2-3/8" x 1-1/2" x 1/8" nominal sized, die-formed channel, with holes to mount a total of (16) 3" x 4" timbers and welded in a back-to-back configuration.
- Benches shall be permanently anchored by embedding bench legs in concrete footings.
- **Standard:** Frames shall be finished in Black powder coat (indicated by "/CB" in model no.).
- **Standard:** Lumber shall be Indonesian Balau Wood 3" x 4" nominal sized timbers (indicated by "IB" in model no.). All timbers shall be precision drilled for fast, easy assembly and shall have all exposed edges removed to a 3/8" radius with a bullnose profile timber used on top and front positions.
- All 3/8" dia. galvanized carriage bolts and nuts shall be provided to fasten frames to lumber.
- **Optional:** Color choices of powder coated steel frame components. For optional colors choices see Specification Bulletin # SPC-CO-001.
- **Optional:** Lumber shall be #1 grade Southern Yellow Pine, pressure treated and kiln dried after treatment (KDAT) to preserve wood against decay, or Construction Heart Redwood. (To specify, change "IB" in model no. to "TP" for Treated Pine, e.g. BE65/CB-3TP34, or to "CO" for Construction Heart Redwood, e.g. BE65/CB-3CO34).

R.J. THOMAS MFG. CO., INC.

P.O. Box 946 • Cherokee, IA 51012-0946 • PH: 712-225-5115 • 800-762-5002 • FAX: 712-225-5796

E-mail: pilotrock@rjthomas.com • Web Site: <http://www.pilotrock.com>

© 2004 R. J. Thomas Mfg. Co., Inc. PILOT ROCK® Park Equipment is a registered trademark of R. J. Thomas Mfg. Co., Inc.

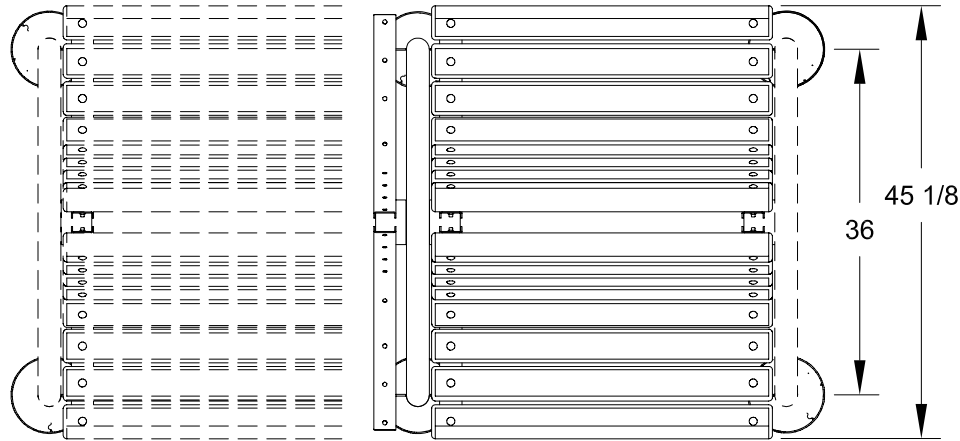

c
 (Length added to bench
 per extension unit)

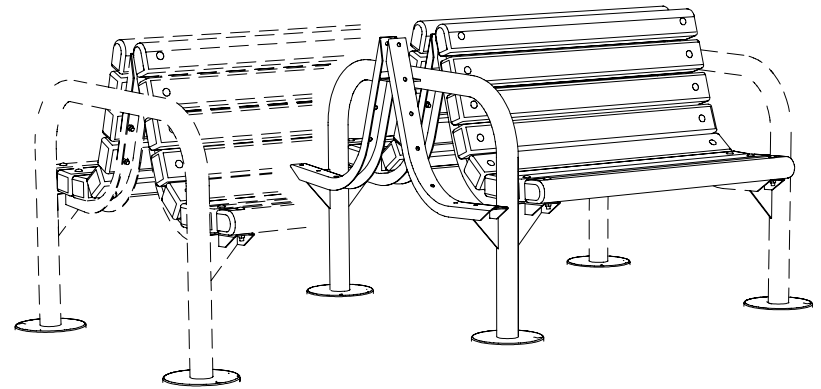

MODEL NUMBER	DIMENSION		
	a	*b	c
BE65-3	35 1/2	38 3/8	38 3/8
BE65-4	47 1/2	50 3/8	50 3/8

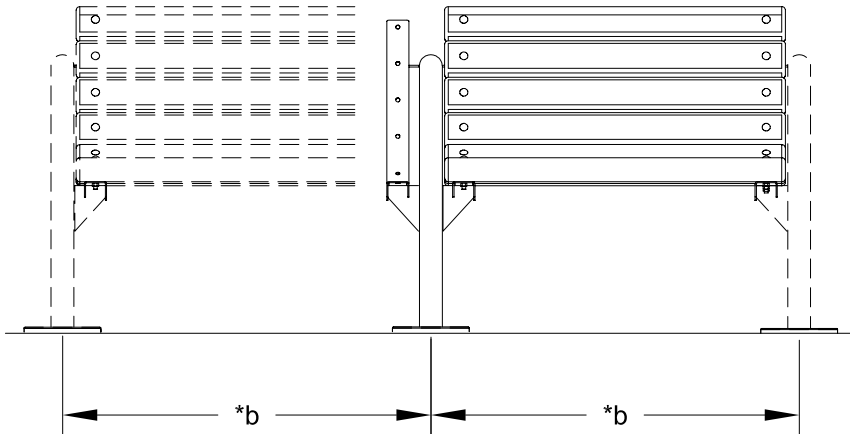

*CTR TO CTR
OF FRAME POSTS

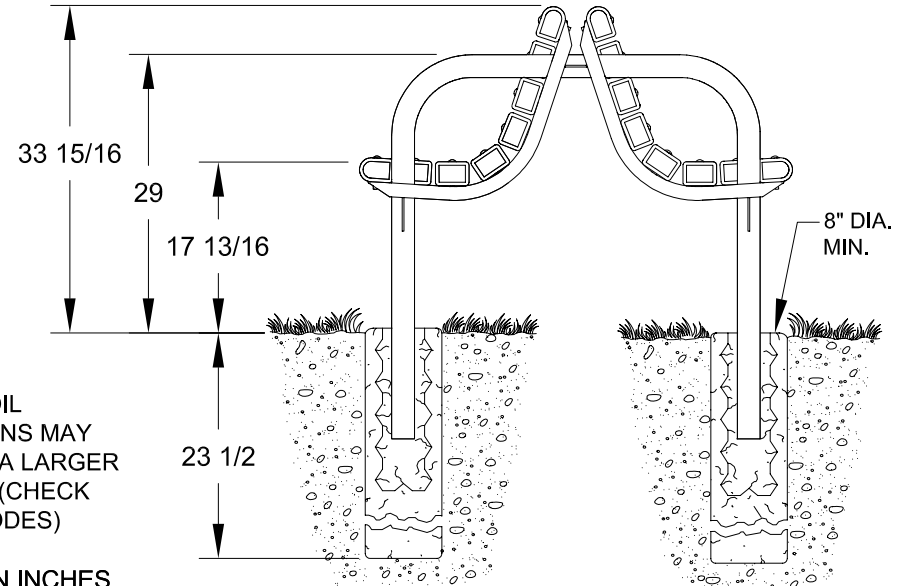

NOTE:
LOCAL SOIL
CONDITIONS MAY
REQUIRE A LARGER
FOOTING (CHECK
LOCAL CODES)

ALL DIMENSIONS IN INCHES

R. J. **THOMAS MFG. CO., INC.**
P.O. Box 946 • Cherokee, IA 51012

DRAWN BY
WWM

TITLE RIVerview SERIES MODEL BE65 3 AND 4 FOOT BACK TO BACK CONTOUR
EMBEDDED MOUNT BENCH EXTENSION WITH 3" X 4" LUMBER TIMBERS (SHOWN
WITH RIVerview SERIES MODEL B65 BENCH IN PHANTOM)

DATE 3-25-04

DWG. NO. AI-1609