



*Model SCXB/G-6TP24 Embedded Mount Bench
with Hot-Dip Galvanized Frames,
6 Ft. long with Treated Southern Yellow Pine 2" x 4" Slats.*

- **Extra heavy design to be stronger and more stable with a simple, clean style**
- **Sturdy, formed and welded steel frame construction**
- **Frames are Hot-Dip Galvanized after fabrication for superior corrosion resistance**
- **Precision drilled lumber**
- **Quality construction throughout**

SPECIFICATIONS:

- **Model SCXB** end frames shall be one-piece, welded construction with a back and seat bracket of 2-3/8" x 1-1/2" x 1/8" nominal sized, die-formed channel, and a 2.375" (2-3/8") O.D. post to meet 2" nominal steel pipe size specifications. Bench leg shall be permanently embedded in concrete footings.
- **Model SCXB/G-4TP24** shall be 4 ft. long (nom.).
- **Model SCXB/G-6TP24** shall be 6 ft. long (nom.).
- **Model SCXB/G-8TP24** shall be 8 ft. long (nom.).
- **Standard:** Frames shall be hot-dip galvanized after fabrication to ASTM-A123 to maintain an average zinc coating of 2.0 oz. per sq. ft. of surface area (indicated by "/G" in model no.).
- **Standard:** Seat and back shall be (6) 2" x 4" (nom.) Treated #1 Southern Yellow Pine slats, pressure treated and kiln dried after treatment (KDAT) to preserve wood against decay (indicated by "TP24" at end of the model no.).
- All 3/8" dia. galvanized carriage bolts and nuts shall be provided to fasten frames and center channel to lumber.
- **Optional:** Frames shall be finished in black enamel paint. (To specify, change "/G" to "/B" in model no., e.g. SCXB/B-6TP24.)
- **Optional:** Color choices of powder coated steel frame components. For optional colors choices see Specification Bulletin # SPC-CO-001.
- **Optional:** Seat and back shall be Untreated #1 Southern Yellow Pine is readily available (To specify, change "TP" in model no. to "UP", e.g. SCXB/G-6UP24). (Cedar, Fir, and Redwood are available when in stock – please inquire.)
- **Optional:** Seat and back shall be available with (2) 2" x 10" (nom.) planks (specify by changing "24" in model no. to "21", e.g. SCXB/G-6TP21).

AVAILABLE OPTIONS

- 4', 6' or 8' models
- Powder Coat Finish in choice of colors or Black Enamel
- Painted steel frame components
- Untreated #1 Southern Yellow Pine, Cedar, Fir, or Redwood lumber
- Custom Lettering and Plaques available (call for details)
- Armrests

R.J. THOMAS MFG. CO., INC.

P.O. Box 946 • Cherokee, IA 51012-0946 • PH: 712-225-5115 • 800-762-5002 • FAX: 712-225-5796
E-mail: pilotrock@rjthomas.com • Web Site: <http://www.pilotrock.com>

© 2005 R. J. Thomas Mfg. Co., Inc. PILOT ROCK® Park Equipment is a registered trademark of R. J. Thomas Mfg. Co., Inc.

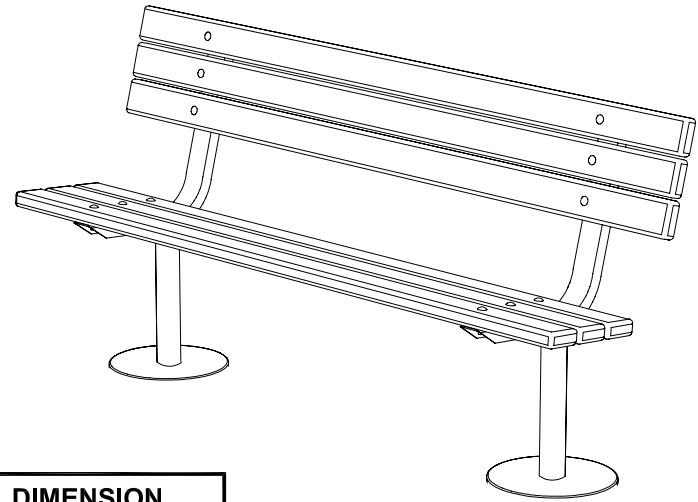
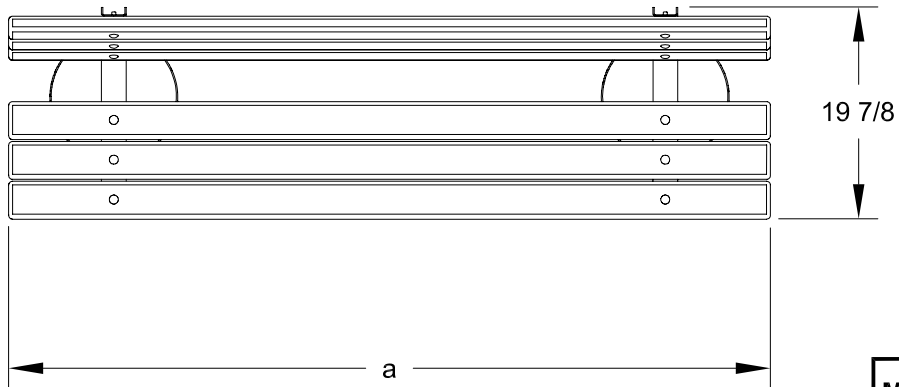

MODEL NUMBER	DIMENSION	
	a	b
SCXB-4	47-1/2	36
SCXB-6	71-1/2	51-3/4
SCXB-8	95-1/2	70

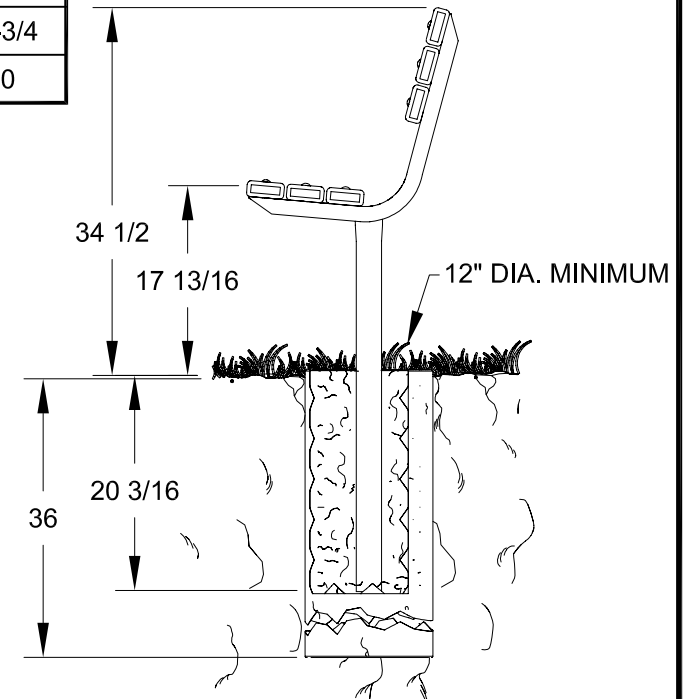
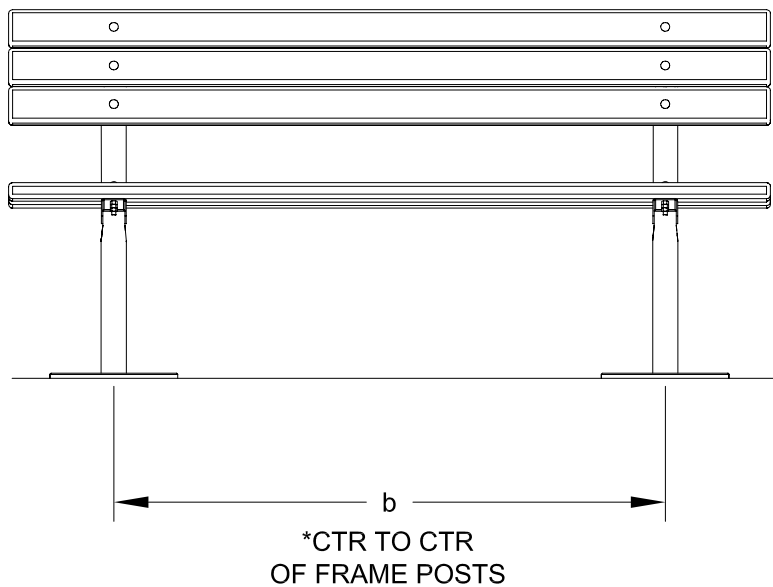

NOTE:
LOCAL SOIL
CONDITIONS
MAY REQUIRE
A LARGER
FOOTING
(CHECK LOCAL
CODES)

ALL DIMENSIONS IN INCHES

R. J. **THOMAS MFG. Co., Inc.**
P.O. Box 946 • Cherokee, IA 51012

DRAWN BY
WWM

TITLE MODEL SCXB EXTRA HEAVY DUTY 4, 6, AND 8 FOOT EMBEDDED MOUNT BENCH
WITH 2" X 4" LUMBER SLATS

DATE 1-18-05

DWG. NO. **AI-1627**