



Model SWB/G-6TP 6 Ft. Embedded Mount Bench
with Hot Dip Galvanized Frames
and Pressure Treated Southern Yellow Pine 3" x 4" timbers.

- **Sturdy welded steel construction**
- **Flat design with Bull-nosed outside timbers**
- **Pressure Treated Lumber resists decay**
- **Precision drilled 3" x 4" Timbers**
- **Fast, easy assembly using 3/8" dia. galvanized carriage bolts**
- **Quality construction throughout**

SPECIFICATIONS:

- **Model SWB** end frames shall be one-piece welded construction with 2-1/2" x 2-1/2" square steel post. Seat bracket shall be constructed of 3/8" x 4" A-36 flat steel bar to mount four 3" x 4" timbers.
- Benches shall be permanently anchored by embedding bench legs in concrete footings.
- **Model SWB-4TP** shall be a nom. 4 ft. in length.
- **Model SWB-6TP** shall be a nom. 6 ft. in length.
- **Model SWB-8TP** shall be a nom. 8 ft. in length.
- **Standard:** Finish shall be hot-dip galvanized after fabrication to ASTM-A123 to maintain an average zinc coating of 2.0 oz. per sq. ft. of surface area (indicated by "/G" in model no.).
- 3/8" galvanized carriage bolts and nuts shall be provided for timber connections.
- **Standard:** Lumber shall be #1 grade Southern Yellow Pine 3" x 4" nominal sized timbers pressure treated (KDAT) to preserve wood against decay (indicated by "TP" in model no.). All lumber shall be surface planed on all four sides; precision drilled for fast, easy assembly; and shall have all exposed edges removed to a 3/8" radius. Outside timbers shall have a bull-nose radius on outside edges.
- **Optional:** Color choices of powder coated steel frame components. For optional colors choices see Specification Bulletin # SPC-CO-001.
- **Optional:** Frame shall be finished in Black enamel paint. To specify, change "/G" in model no. to "/B", e.g. SWB/B-6TP.
- **Optional:** Construction Heart Redwood timbers are available. To specify, change "TP" in model no. to "CO", e.g. SWB/G-6CO. Other lumber species are available when in stock — please inquire.
- **Optional:** In lieu of carriage bolts, zinc plated lag screws shall be provided for timber connections — please specify when ordering.

AVAILABLE OPTIONS

- 4', 6', or 8' models
- Powder Coat Finish in choice of colors or Black Enamel
- Painted steel frame components
- Construction Heart Redwood lumber
- Armrests

R.J. THOMAS MFG. CO., INC.

P.O. Box 946 • Cherokee, IA 51012-0946 • PH: 712-225-5115 • 800-762-5002 • FAX: 712-225-5796

E-mail: pilotrock@rjthomas.com • Web Site: <http://www.pilotrock.com>

© 2005 R. J. Thomas Mfg. Co., Inc. PILOT ROCK® Park Equipment is a registered trademark of R. J. Thomas Mfg. Co., Inc.

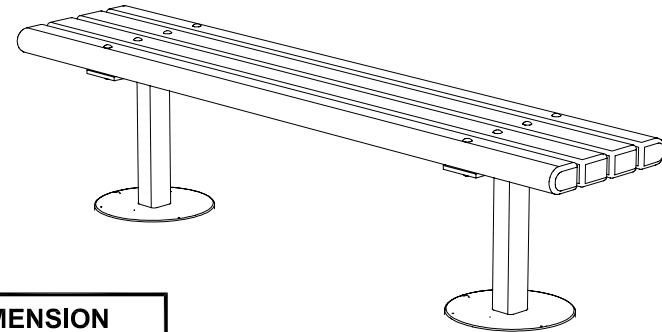

MODEL NUMBER	DIMENSION	
	a	b
SWB-4	47-1/2	36
SWB-6	71-1/2	48
SWB-8	95-1/2	68

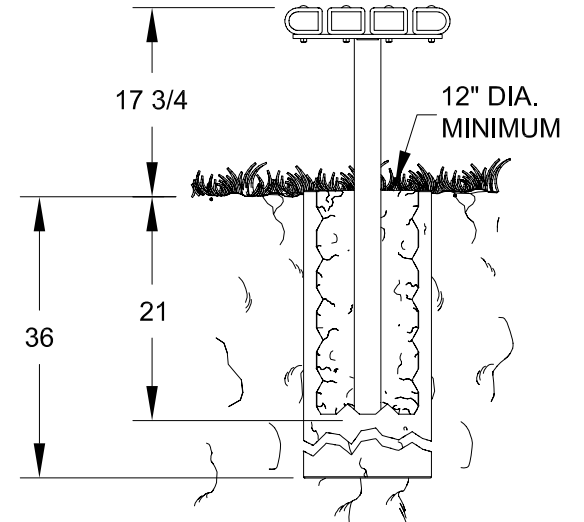
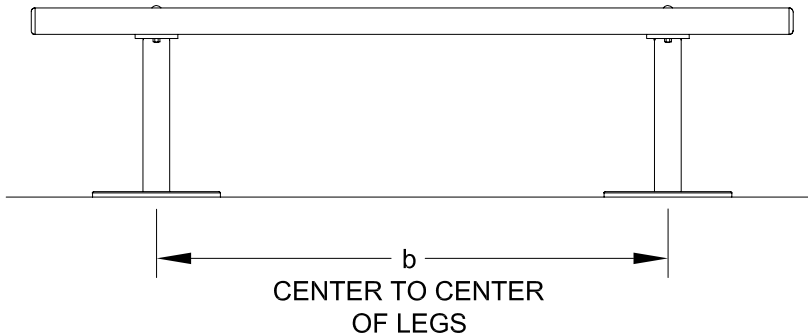

NOTE:
LOCAL SOIL
CONDITIONS
MAY REQUIRE
A LARGER
FOOTING
(CHECK LOCAL
CODES)

ALL DIMENSIONS IN INCHES

R. J. **THOMAS MFG. Co., INC.**
P.O. Box 946 • Cherokee, IA 51012

DRAWN BY
WWM

TITLE MODEL SWB 4, 6, AND 8 FOOT EMBEDDED MOUNT FLAT BENCH
WITH 3" X 4" LUMBER TIMBERS

DATE 4-19-05

DWG. NO. **AI-1652**