



*Model B92/CN-4IB34 Surface Mount Bench  
with Green Powder Coat Frames, 4 Ft. long  
with Indonesian Balau Wood seat timbers.*

- **Comfortable contour seat design**
- **Frame design includes comfortable armrests**
- **Sturdy cast iron end frames. Formed and welded steel seat and brace components**
- **Powder Coat frame finish**
- **Indonesian Balau Wood 3" x 4" Timbers**
- **Easy bolt together assembly**
- **Quality construction throughout**

### **SPECIFICATIONS:**

- **Model B92** end frames shall be one-piece molded cast iron construction.
- **Model B92-4** shall be a nom. 4 ft. in length.
- **Model B92-6** shall be a nom. 6 ft. in length.
- **Model B92-8** shall be a nom. 8 ft. in length.
- Seat timbers shall attach to end frame by means of a 7 ga. formed and welded steel bracket.
- Frames shall be supported by a horizontal brace of 1.9" O.D. x 11 ga. wall steel pipe.
- 6 and 8 foot models shall include a center vertical support that connects all seat timbers and the horizontal brace to prevent deflection of timbers.
- Benches shall be permanently surface mounted using 9/16" dia. holes provided in each leg foot for use with anchors (anchors not included).
- **Standard:** Frames and brace shall be finished in Black powder coat (indicated by "/CB" in model no.).
- **Standard:** Lumber shall be Indonesian Balau Wood 3" x 4" nominal sized timbers (indicated by "IB" in model no.). All timbers shall be precision drilled for fast, easy assembly and shall have all exposed edges removed to a 3/8" radius with a bullnose profile timber used on outside positions.
- All 1/2" dia. black zinc coated stainless steel bolts and nuts for frame assembly, and 3/8" stainless steel lag screws for attachment of seat timbers shall be provided to fasten frames to seat.
- **Optional:** Color choices of powder coated frame components. For optional colors choices see Specification Bulletin # SPC-CO-001.

### **AVAILABLE OPTIONS**

- 4', 6', or 8' models
- Choice of colors of Powder Coat Finish on frame components

**R.J. THOMAS MFG. CO., INC.**

P.O. Box 946 • Cherokee, IA 51012-0946 • PH: 712-225-5115 • 800-762-5002 • FAX: 712-225-5796

E-mail: [pilotrock@rjthomas.com](mailto:pilotrock@rjthomas.com) • Web Site: <http://www.pilotrock.com>

© 2006 R. J. Thomas Mfg. Co., Inc. PILOT ROCK® Park Equipment is a registered trademark of R. J. Thomas Mfg. Co., Inc.

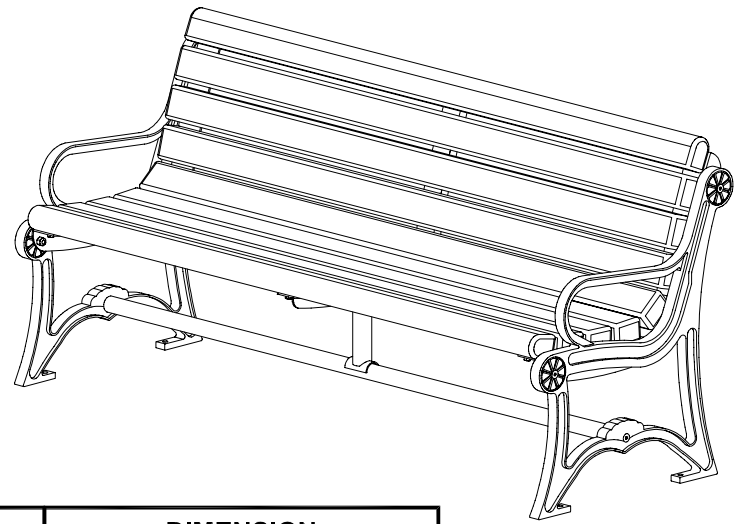
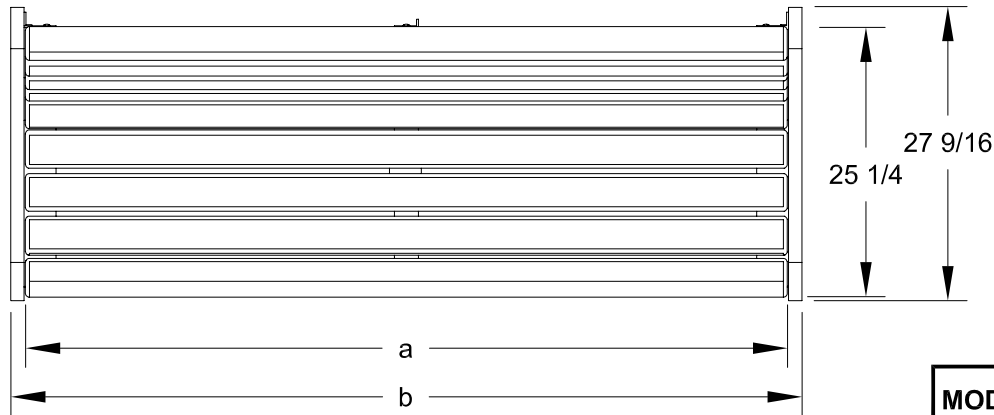

MODEL NUMBER	DIMENSION		
	a	b	c
B92-4	47 1/2	50 1/4	49
B92-6	71 1/2	74 1/4	73
B92-8	95 1/2	98 1/4	97

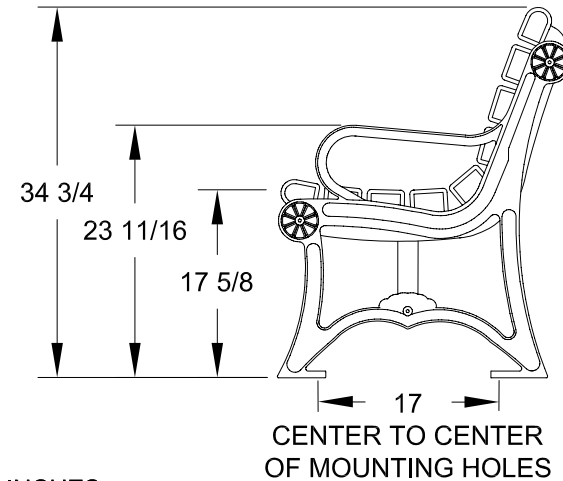
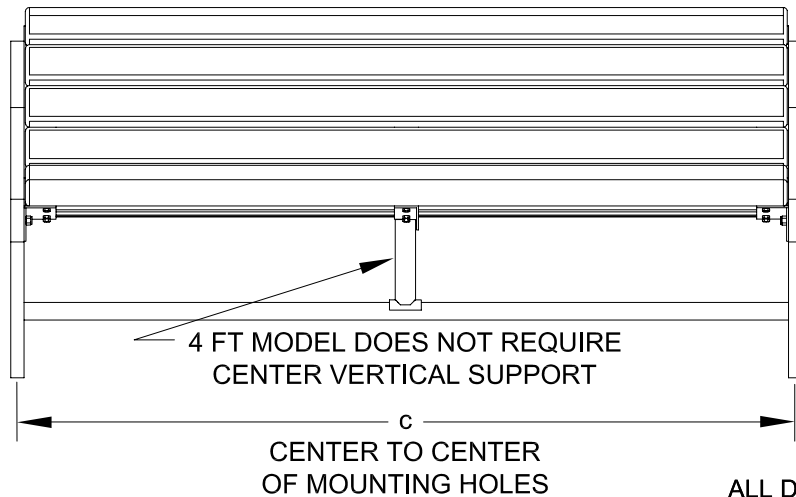

ALL DIMENSIONS IN INCHES

R. J. **THOMAS MFG. CO., INC.**  
P.O. Box 946 • Cherokee, IA 51012

DRAWN BY  
**WWM**

TITLE OAK KNOLL SERIES MODEL B92 4, 6, AND 8 FOOT CONTOUR SURFACE MOUNT BENCH WITH CAST IRON END FRAMES AND 3" X 4" LUMBER SEAT AND BACK TIMBERS

DATE 10-03-06

DWG. NO. **AI-1736**