



*Model B90/CN-6SS Surface Mount Bench
with Red Powder Coat Frames, 6 Ft. long
with Red Powder Coat Steel Strap seat.*

- **Comfortable seat design may be accessed from either side**
- **Sturdy cast iron end frames. Formed and welded steel seat and brace components**
- **Powder Coat frame finish**
- **Powder Coated finish on Steel Strap seat**
- **Easy bolt together assembly**
- **Quality construction throughout**

SPECIFICATIONS:

- **Model B90** end frames shall be one-piece molded cast iron construction.
- **Model B90-4** shall be a nom. 4 ft. in length.
- **Model B90-6** shall be a nom. 6 ft. in length.
- **Model B90-8** shall be a nom. 8 ft. in length.
- Frames shall be supported by a horizontal brace of 1.9" O.D. x 11 ga. wall steel pipe.
- **Standard:** Seats shall be a one piece welded assembly made of 2" wide by 1/8" thick steel straps welded to 2-3/8" dia. x .120 wall steel tubes and 7 ga. end plates. Straps shall be wrapped around tubes to form a smooth curved outer edge of seat.
- Benches shall be permanently surface mounted using 9/16" dia. holes provided in each leg foot for use with anchors (anchors not included).
- **Standard:** Frames, braces, and seat shall be finished in Black powder coat (indicated by "/CB" in model no.).
- All 1/2" dia. black zinc coated stainless steel bolts and nuts shall be provided to fasten frames to seat.
- **Optional:** Color choices of powder coated steel finish. For optional colors choices see Specification Bulletin # SPC-CO-001.

AVAILABLE OPTIONS

- 4', 6', or 8' models
- Choice of colors of Powder Coat Finish

R.J. THOMAS MFG. CO., INC.

P.O. Box 946 • Cherokee, IA 51012-0946 • PH: 712-225-5115 • 800-762-5002 • FAX: 712-225-5796

E-mail: pilotrock@rjthomas.com • Web Site: <http://www.pilotrock.com>

© 2006 R. J. Thomas Mfg. Co., Inc. PILOT ROCK® Park Equipment is a registered trademark of R. J. Thomas Mfg. Co., Inc.

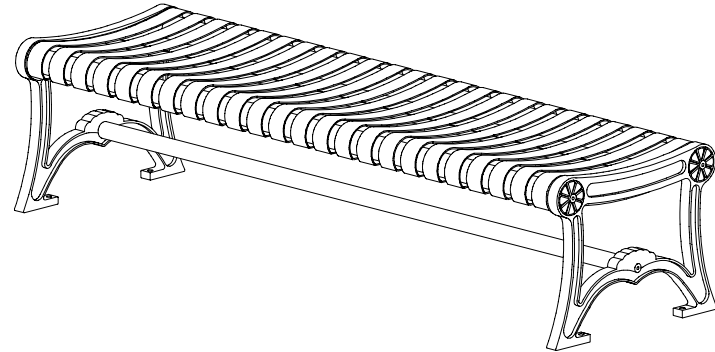
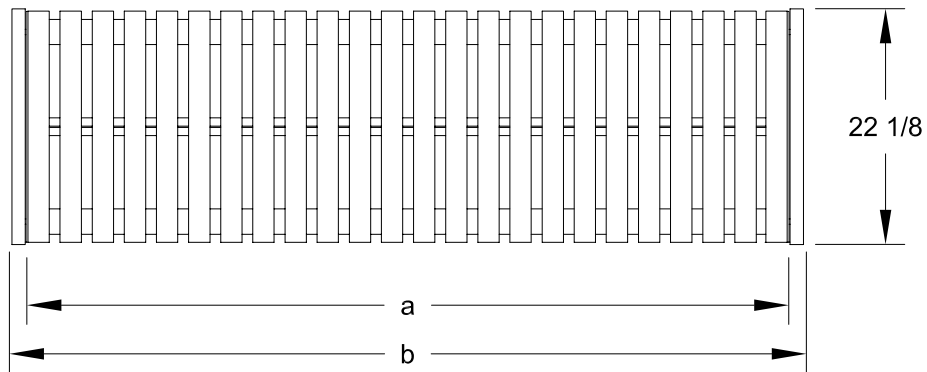

MODEL NUMBER	DIMENSION		
	a	b	c
B90-4	47 1/2	50 1/4	49
B90-6	71 1/2	74 1/4	73
B90-8	95 1/2	98 1/4	97

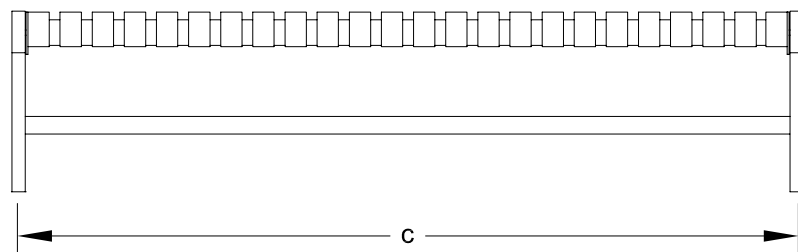

CENTER TO CENTER
OF MOUNTING HOLES

ALL DIMENSIONS IN INCHES

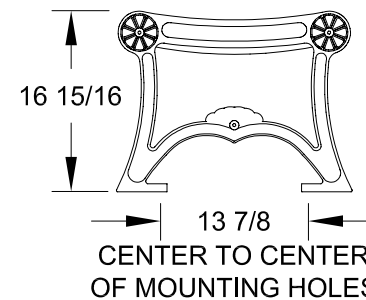

R. J. **THOMAS MFG. Co., INC.**
P.O. Box 946 • Cherokee, IA 51012

DRAWN BY
WWM

TITLE OAK KNOLL SERIES MODEL B90 4, 6, AND 8 FOOT FLAT SURFACE MOUNT BENCH
WITH CAST IRON END FRAMES AND STEEL STRAP SEAT

DATE 10-04-06

DWG. NO. **AI-1741**