



**Model SQT/G-4PC** 5 Plank, 48" Square Top, Portable Square Table with Hot-Dip Galvanized Frame and Green 100% Recycled Plastic Planks

- **Square design optimizes table top usage and creates a more intimate setting**
- **Square table fits into more compact areas**
- **Nontip, nontrip, walk-through design**
- **All welded corner frames are fabricated from 1-1/2" diameter steel pipe**
- **Cross braces square up the corner frames and strengthen the table**
- **100% Recycled Plastic Seat and Top Planks with solid color and U.V. stabilizer for ultraviolet protection**
- **Fast, easy assembly using 3/8" dia. galvanized carriage bolts**
- **Quality construction throughout**

#### AVAILABLE OPTIONS

- 3' or 4' square models
- Powder Coat Finish in choice of colors or Black Enamel Painted steel frame components
- Choice of colors of Recycled Plastic
- Umbrellas

### 3 and 4 Ft. Square Models

#### SPECIFICATIONS:

- Model **SQT-3** shall have a nominal 38" square table top utilizing (4) top planks.
- Model **SQT-4** shall have a nominal 48" square table top utilizing (5) top planks.
- Table frame design shall incorporate the nontip, nontrip, walk-through features. Bends shall be tightly formed to prevent tipping when weight is on one side.
- Four **SQT series** corner frames shall each be of one-piece welded construction made from 1-1/2" dia. x 1/8" wall structural steel tubing and 1-3/4" x 1-3/4" x 1/8" A-36 structural steel angle.
- Nominal table height shall be 30". Nominal seat height shall be 18".
- Top planks shall be supported and attached to corner frames by two 1-3/4" x 1-3/4" x 1/8" structural steel top angles.
- Corner frames shall be connected by two cross braces constructed of 1-5/16" O.D. steel pipe.
- All galvanized carriage bolts and nuts shall be provided for table assembly.
- **Standard:** Frames, top angles, and cross braces shall be hot-dip galvanized after fabrication to ASTM-A123 to maintain an average zinc coating of 2.0 oz. per sq. ft. of surface area (indicated by "/G" following the SQT in model no.).
- **Standard:** Tops and Seats shall be made of 100% Recycled Plastic molded into 2" x 10" nominal sized planks with solid Cedar color (indicated by "PC" in model no.) formed throughout and a U.V. stabilizer added for ultra-violet protection.
- **Optional:** Color choices of powder coated steel frame components. For optional colors choices see Specification Bulletin # SPC-CO-001.
- **Optional:** Frames, top angles, and cross braces shall be finished in black enamel. To specify, change "/G" following the SQT to "/B" in model no., e.g. SQT/B-4PW.
- **Optional:** Color choices of Recycled Plastic components. For optional colors choices see Specification Bulletin # SPC-CO-001.
- **Optional:** Tables shall be provided with umbrella holes in table tops and cup and collar sets for mounting umbrellas. To specify, add "/U" to the end of the model no., e.g. SQT/G-3PW/U.

**R.J. THOMAS MFG. CO., INC.**

P.O. Box 946 • Cherokee, IA 51012-0946 • PH: 712-225-5115 • 800-762-5002 • FAX: 712-225-5796

E-mail: [pilotrock@rjthomas.com](mailto:pilotrock@rjthomas.com) • Web Site: <http://www.pilotrock.com>

© 2003 R. J. Thomas Mfg. Co., Inc. PILOT ROCK® Park Equipment is a registered trademark of R. J. Thomas Mfg. Co., Inc.

**NOTE: SQT-3 TABLES HAVE (4) TOP PLANKS  
SQT-4 TABLES HAVE (5) TOP PLANKS**

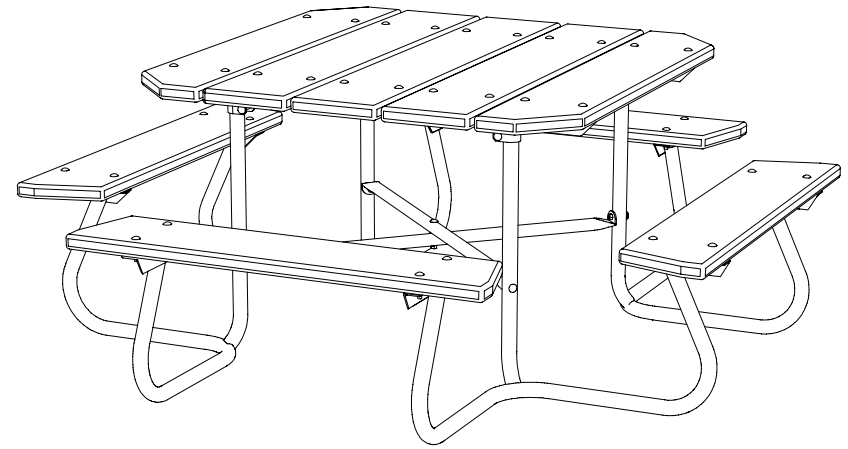
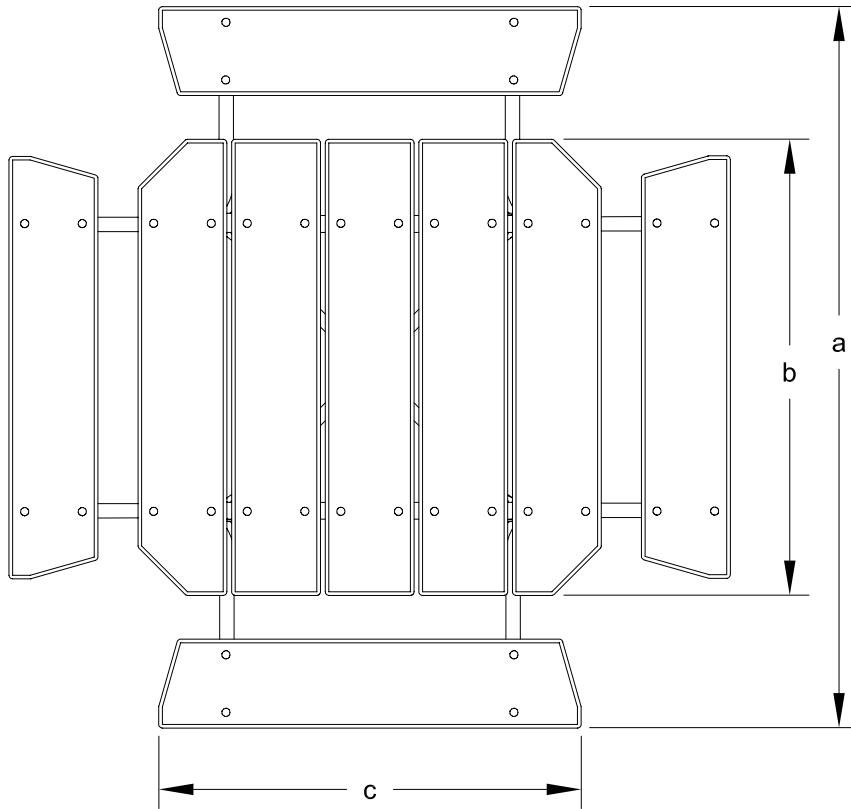

MODEL NUMBER	DIMENSION			
	a	b	c	d
SQT-3	65 1/8	38	33 3/8	4 1/16
SQT-4	75 1/8	47 1/2	44	4 3/16

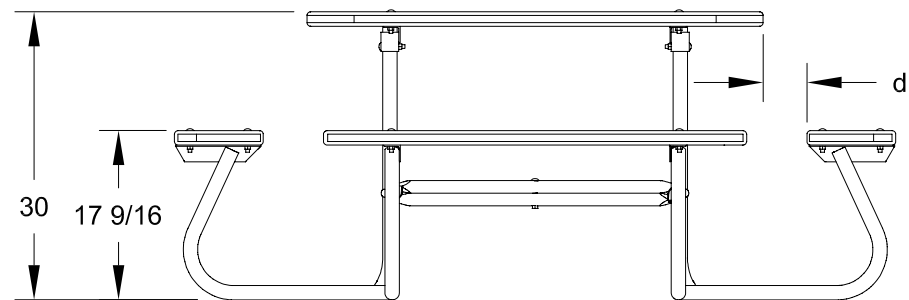
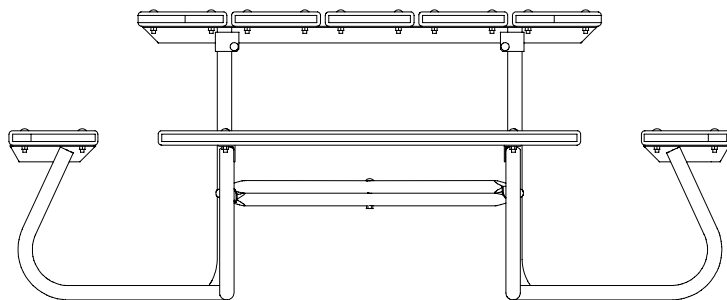

ALL DIMENSIONS IN INCHES

R. J. **THOMAS MFG. Co., Inc.**  
P.O. Box 946 • Cherokee, IA 51012

DRAWN BY  
**WWM**

TITLE SQT SERIES 3 AND 4 FOOT PORTABLE SQUARE TABLES WITH RECYCLED PLASTIC  
TOP AND SEAT PLANKS

DATE 7-13-06

DWG. NO. **AI-1497**