

PQT Series Pedestal Square Table with Recycled Plastic Planks

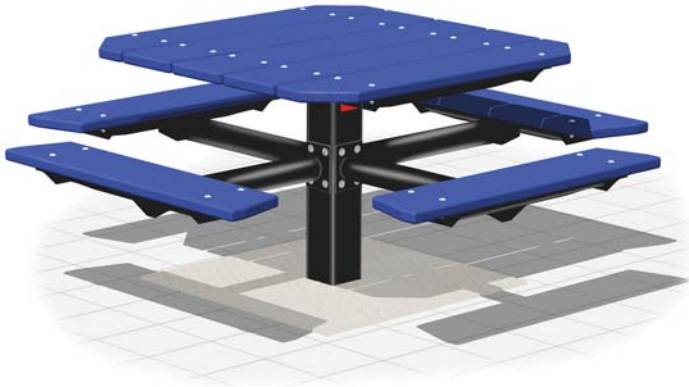

Model PQT/CB-4PU 5 Plank, 48" Square Top, Embedded Mount Table with Black Powder Coat Frame and Blue Recycled Plastic Planks

- **Square design optimizes table top usage and creates a more intimate setting**
- **Square table fits into more compact areas**
- **Permanent embedded mounting**
- **Sturdy 5-3/8" square center pedestal, 3-1/2" diameter round radial seat supports**
- **100% recycled plastic seat and top planks with solid color and U.V. stabilizer for ultraviolet protection**
- **Quality construction throughout**

AVAILABLE OPTIONS

- **3' or 4' square models**
- **Powder Coat Finish in choice of colors or Black Enamel Painted steel frame components**
- **Choice of colors of Recycled Plastic**
- **Umbrellas**
- **Surface mount base plate**

SPECIFICATIONS:

- **PQT Series** table frame shall incorporate a 5-3/8" square single center pedestal post designed to be embedded in a concrete footing.
- Four seat support frames shall each be a one-piece welded construction of 3-1/2" dia. x 11 ga. wall structural steel tubing, a 2-3/8" dia. 10 ga. wall tube, and 1-3/4" x 1-3/4" x 1/8" A-36 structural steel angles designed to resist lateral torsion and deflection when loaded.
- Frame shall assemble in a theft-proof manner with all fasteners extending into the central post to prevent removal once the table is assembled.
- Model **PQT/G-3PC** shall have a nominal 38" square table top utilizing (4) top planks.
- Model **PQT/G-4PC** shall have a nominal 48" square table top utilizing (5) top planks.
- Nominal table height shall be 31-13/16". Nominal seat height shall be 19-7/8".
- Top planks shall be supported by a subframe of 1-3/4" x 1-3/4" x 1/8" A-36 structural steel angle, 10 ga. steel channel, and 2-3/8" round tubing.
- All galvanized carriage bolts and nuts shall be provided for table assembly.
- **Standard:** All frame components shall be hot-dip galvanized after fabrication to ASTM-A123 to maintain an average zinc coating of 2.0 oz. per sq. ft. of surface area (indicated by "/G" in model no.).
- **Standard:** Tops and Seats shall be made of 100% Recycled Plastic molded into 2" x 10" nominal sized planks with solid Cedar color (indicated by "PC" in model no.) formed throughout and a U.V. stabilizer added for ultra-violet protection.
- **Optional:** All frame components shall be finished in black enamel. To specify, change "/G" to "/B" in model no., e.g. PQT/B-4PC.
- **Optional:** Color choices of Recycled Plastic components. For optional colors choices see Specification Bulletin # SPC-CO-001.
- **Optional:** Color choices of powder coated steel frame components. For optional colors choices see Specification Bulletin # SPC-CO-001.
- **Optional:** Tables shall be provided with umbrella holes in table tops and cup and collar sets for mounting umbrellas. To specify, add "/U" to the end of the model no., e.g. PQT/G-3PC/U.
- **Optional:** Frame shall be provided with a 3/8" x 15-3/4" x 15-3/4" steel base plate to bolt table to existing concrete pad. To specify add "/P" after the "PQT" in the model no., e.g. PQT/P/G-4PC. (Anchor bolts not included.)

R.J. THOMAS MFG. CO., INC.

P.O. Box 946 • Cherokee, IA 51012-0946 • PH: 712-225-5115 • 800-762-5002 • FAX: 712-225-5796

E-mail: pilotrock@rjthomas.com • Web Site: <http://www.pilotrock.com>

© 2005 R. J. Thomas Mfg. Co., Inc. PILOT ROCK® Park Equipment is a registered trademark of R. J. Thomas Mfg. Co., Inc.

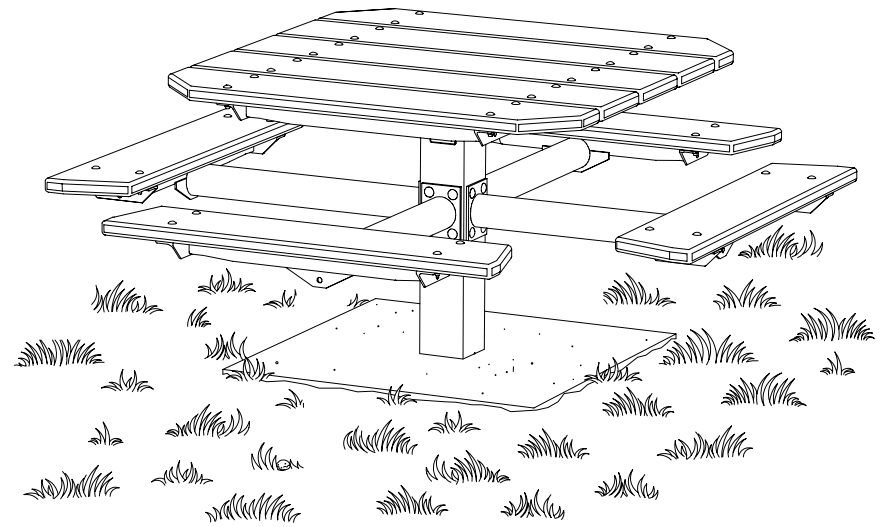
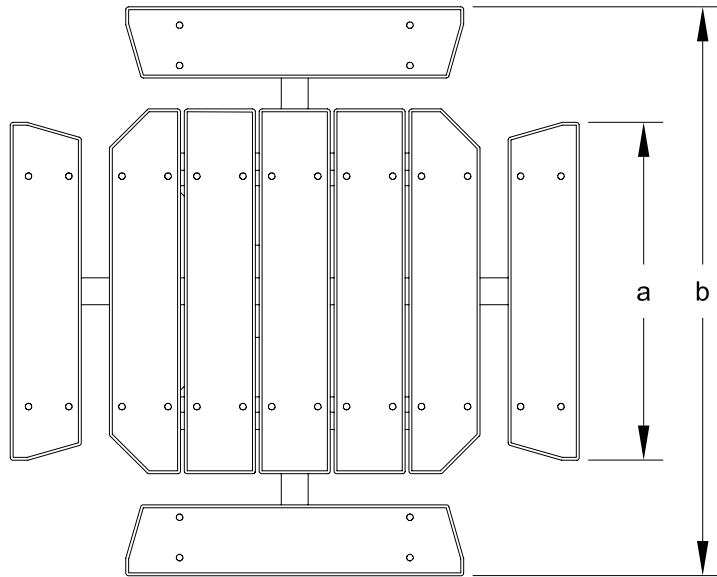

| MODEL NUMBER | DIMENSION | |
|--------------|-----------|----|
| | a | b |
| PQT-3 | 33 3/8 | 68 |
| PQT-4 | 44 | 74 |

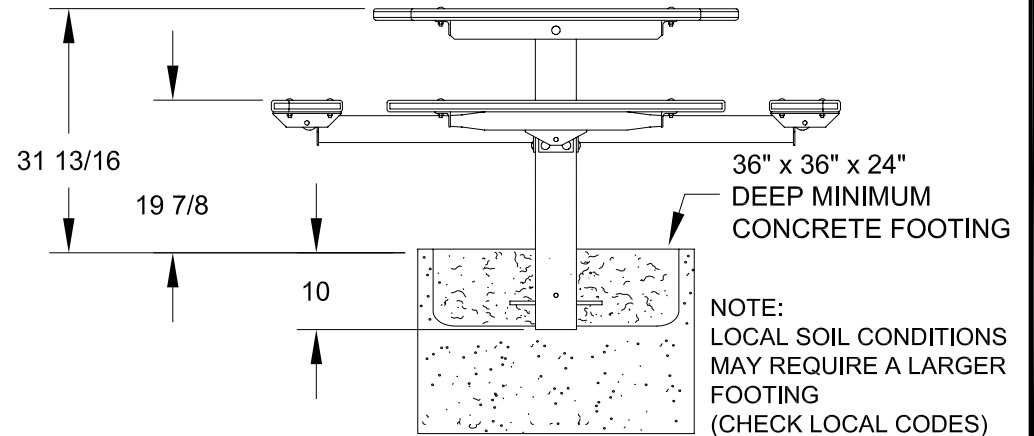
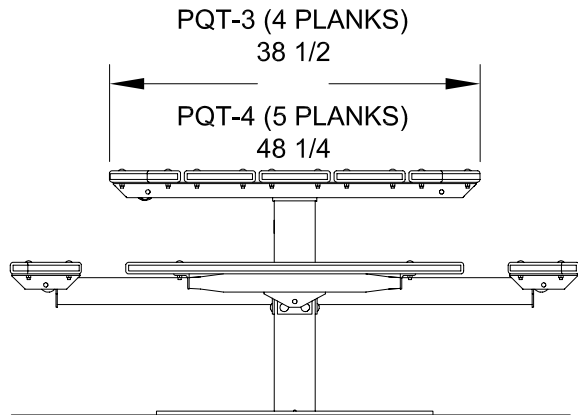

ALL DIMENSIONS IN INCHES

R. J. **THOMAS MFG. CO., INC.**
P.O. Box 946 • Cherokee, IA 51012

DRAWN BY
WWM

TITLE PQT SERIES 3 AND 4 FOOT EMBEDDED MOUNT SQUARE SINGLE PEDESTAL TABLE
WITH RECYCLED PLASTIC TOP AND SEAT PLANKS

DATE 10-16-05

DWG. NO. **AI-1698**