



*Model AT/W-6PC 6 ft. A-Frame Rectangular Table  
with Brown Recycled Plastic Legs  
and Cedar colored Recycled Plastic Top and Seat Planks*

- **Traditional A-Frame design**
- **Sturdy 4" x 6" Recycled Plastic legs**
- **100% Recycled Plastic Seat and Top Planks with solid color and U.V. stabilizer for ultraviolet protection**
- **Pregalvanized steel channel cross-member**
- **Pregalvanized steel channel reinforcements under seats and table top**
- **Quality construction throughout**

### **SPECIFICATIONS:**

- **AT Series** end frames shall be constructed from two 4" x 6" nominal sized timbers forming the legs of the "A" with ends cut at angles to provide firm contact with ground surface. Legs shall be connected at top by a 10 ga. x 2" x 2" formed pregalvanized steel angle which also provides attachment of table top planks. A formed pregalvanized 10 ga. x 1-3/4" x 4" steel channel connects legs at seat height and extends beyond legs to provide mounting and support for seat planks.
- Table shall be supported by diagonal braces of 1-5/16" O.D. pregalvanized steel pipe that shall connect to a die-formed steel channel designed to align and provide attachment to the table top.
- **Model AT/W-6PC** shall have a nominal length of 72".
- **Model AT/W-8PC** shall have a nominal length of 96".
- All 3/8" dia. galvanized carriage bolts and nuts shall be provided to fasten frames, supports, and top and seat planks together.
- **Standard:** Tops and seats shall be made of 100% Recycled Plastic molded into 2" x 10" nominal sized planks with solid Cedar colored (indicated by "PC" in model no.) formed throughout and a U.V. stabilizer added for ultra-violet protection.
- **Standard:** Leg timbers shall be made of 100% Recycled Plastic molded into 4" x 6" nominal sized timber with solid Brown color (indicated by "W" following AT in model no.) formed throughout and a U.V. stabilizer added for ultra-violet protection.
- Recycled Plastic table top and seat planks shall be supported by pregalvanized steel subframe channels.
- **Optional:** 100% Recycled Plastic leg timbers shall be available in a choice of optional colors. For optional colors choices see Specification Bulletin # SPC-CO-001.
- **Optional:** 100% Recycled Plastic top and seat planks shall be available in a choice of optional colors. For optional colors choices see Specification Bulletin # SPC-CO-001.

### **AVAILABLE OPTIONS**

- **6' and 8' lengths**
- **Choice of colors of Recycled Plastic**

**R.J. THOMAS MFG. CO., INC.**

**P.O. Box 946 • Cherokee, IA 51012-0946 • PH: 712-225-5115 • 800-762-5002 • FAX: 712-225-5796**

**E-mail: [pilotrock@rjthomas.com](mailto:pilotrock@rjthomas.com) • Web Site: <http://www.pilotrock.com>**

© 2006 R. J. Thomas Mfg. Co., Inc. PILOT ROCK® Park Equipment is a registered trademark of R. J. Thomas Mfg. Co., Inc.

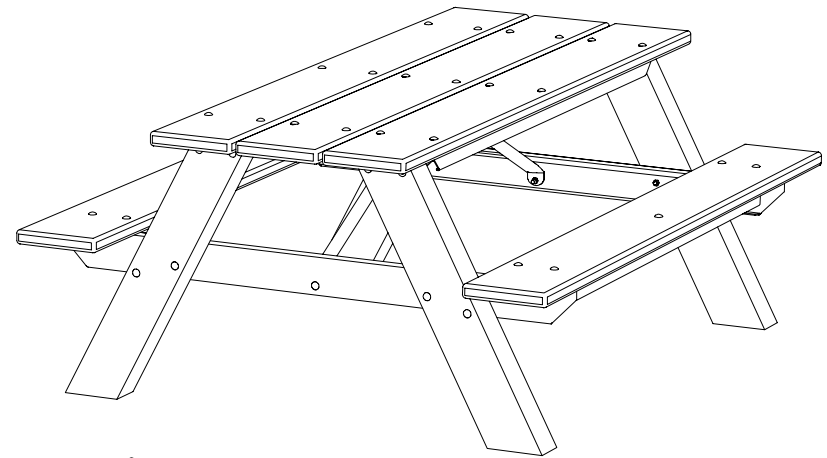
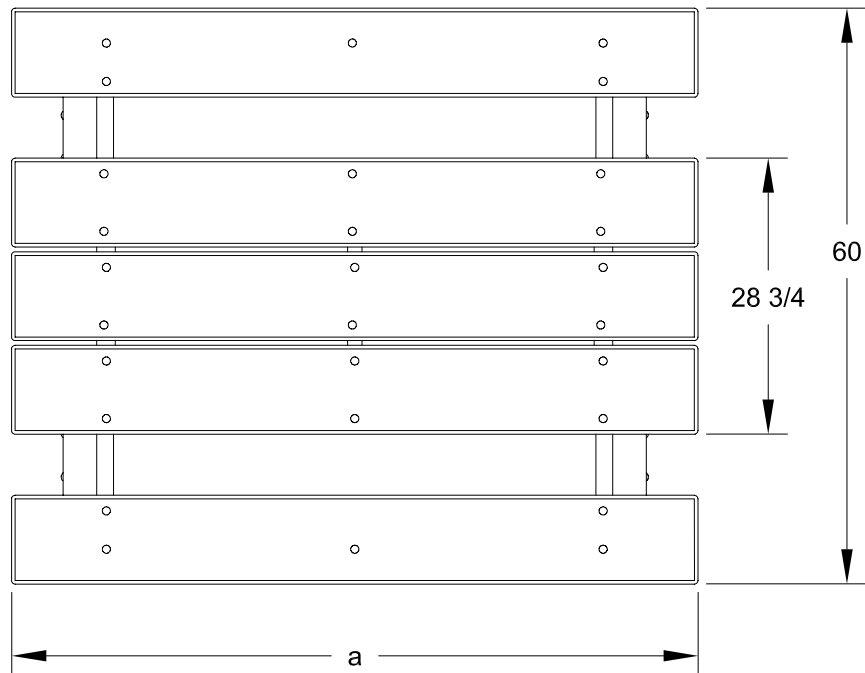

| MODEL NUMBER | DIMENSION |        |
|--------------|-----------|--------|
|              | a         | b      |
| AT-6         | 71 1/2    | 57 1/4 |
| AT-8         | 95 1/2    | 75 1/2 |

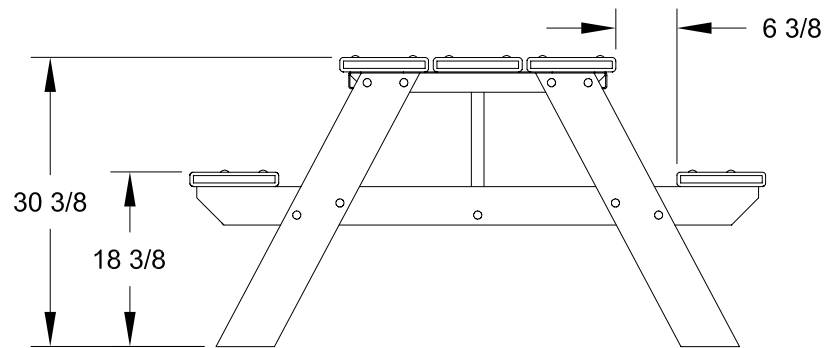
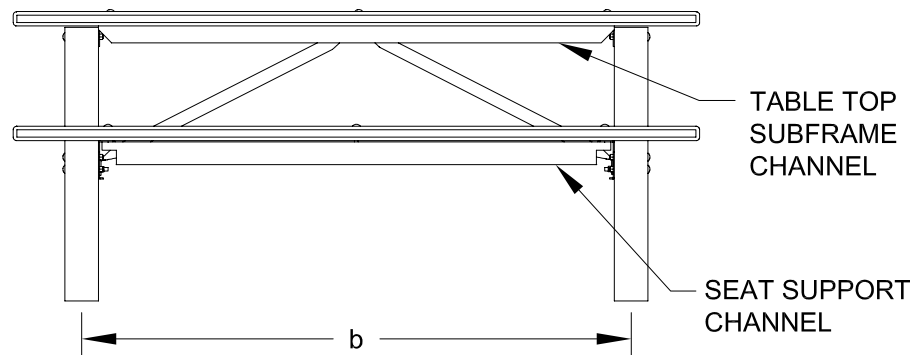

ALL DIMENSIONS IN INCHES

R. J. **THOMAS MFG. Co., Inc.**  
P.O. Box 946 • Cherokee, IA 51012

DRAWN BY  
**WWM**

TITLE AT SERIES 6 AND 8 FOOT A-FRAME TABLE WITH RECYCLED PLASTIC TIMBERS AND PLANKS

DATE 01-26-06

DWG. NO. **AI-1712**