

# PT Series Pedestal Rectangular Table with Recycled Plastic Planks

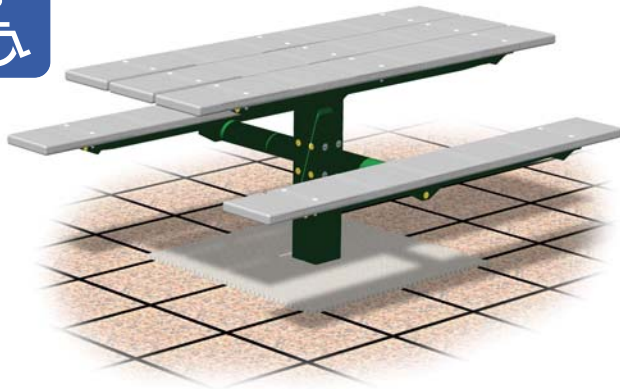

*Model PT/CN-6PA 6 ft. Rectangular Embedded Mount Table  
with Green Powder Coat Frame  
and Gray Recycled Plastic Planks*

- **Permanent embedded mounting**
- **Sturdy 5-3/8" square center pedestal, 3-1/2" diameter round radial seat supports**
- **Wheelchair accessible design**
- **100% Recycled Plastic Seat and Top Planks with solid color and U.V. stabilizer for ultraviolet protection**
- **Quality construction throughout**

## **SPECIFICATIONS:**

- **PT Series** table frame shall incorporate a 5-3/8" square single center pedestal post designed to be embedded in a concrete footing.
- Two seat support frames shall each be a one-piece welded construction of 3-1/2" dia. x 11 ga. wall structural steel tubing, a 2-3/8" dia. 10 ga. wall tube, and 1-3/4" x 1-3/4" x 1/8" A-36 structural steel angles designed to resist lateral torsion and deflection when loaded.
- Frame shall assemble in a theft-proof manner with all fasteners extending into the central post to prevent removal once the table is assembled.
- Model **PT/G-6PC** shall have a nominal length of 72".
- Nominal table height shall be 32". Nominal seat height shall be 20".
- Top planks shall be supported by a subframe of 1-3/4" x 1-3/4" x 1/8" A-36 structural steel angle, 10 ga. steel channel, and 2-3/8" round tubing.
- All galvanized carriage bolts and nuts shall be provided for table assembly.
- **Standard:** All frame components shall be hot-dip galvanized after fabrication to ASTM-A123 to maintain an average zinc coating of 2.0 oz. per sq. ft. of surface area (indicated by "/G" in model no.).
- **Standard:** Tops and Seats shall be made of 100% Recycled Plastic molded into 2" x 10" nominal sized planks with solid Cedar color (indicated by "PC" in model no.) formed throughout and a U.V. stabilizer added for ultra-violet protection.
- **Optional:** Color choices of Recycled Plastic components. For optional colors choices see Specification Bulletin # SPC-CO-001.
- **Optional:** All frame components shall be finished in black enamel. To specify, change "/G" to "/B" in model no., e.g. PT/B-6PC.
- **Optional:** Color choices of powder coated steel frame components. For optional colors choices see Specification Bulletin # SPC-CO-001.
- **Optional:** Frame shall be provided with a 3/8" x 15-3/4" x 15-3/4" steel base plate to bolt table to existing concrete pad. To specify add /P after the PT in the model no., e.g. PT/P/G-6PC. (Anchor bolts not included.)

## **AVAILABLE OPTIONS**

- **Powder Coat Finish in choice of colors or Black Enamel Painted steel frame components**
- **Choice of colors of Recycled Plastic**
- **Surface mount base plate**

**R.J. THOMAS MFG. CO., INC.**

P.O. Box 946 • Cherokee, IA 51012-0946 • PH: 712-225-5115 • 800-762-5002 • FAX: 712-225-5796

E-mail: [pilotrock@rjthomas.com](mailto:pilotrock@rjthomas.com) • Web Site: <http://www.pilotrock.com>

© 2006 R. J. Thomas Mfg. Co., Inc. PILOT ROCK® Park Equipment is a registered trademark of R. J. Thomas Mfg. Co., Inc.

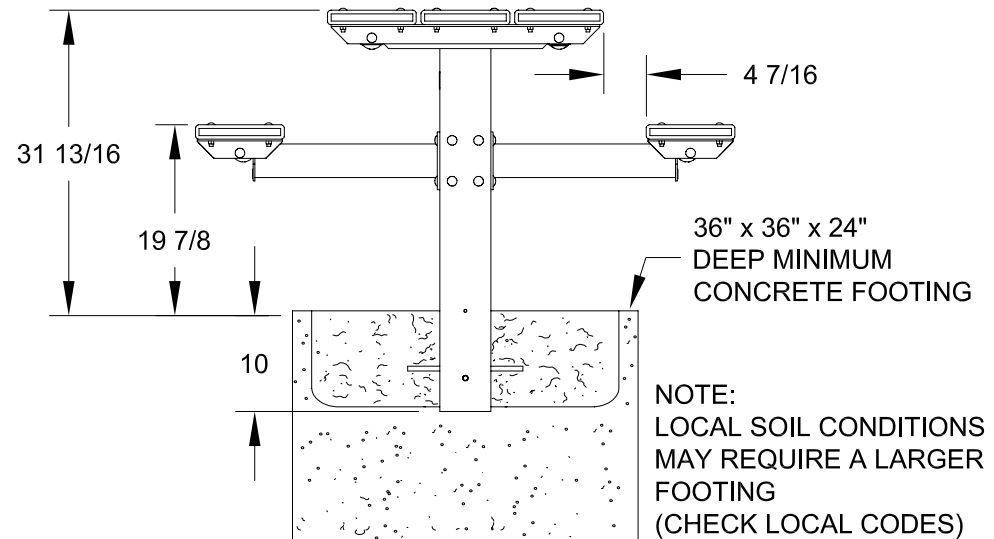
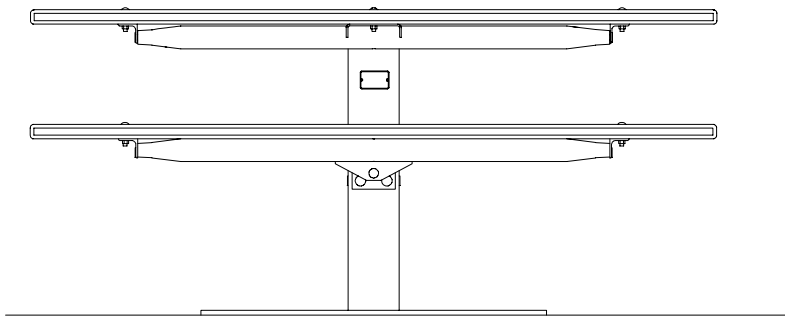
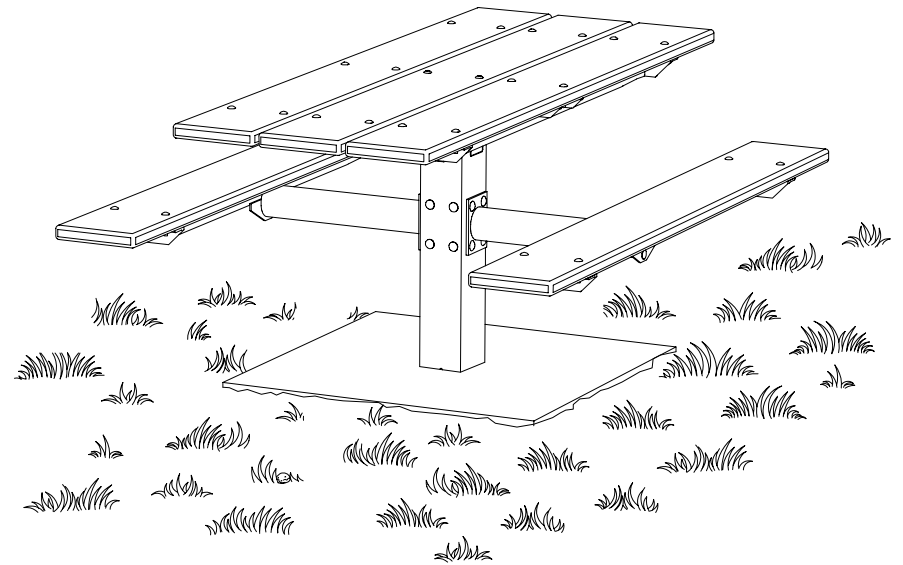
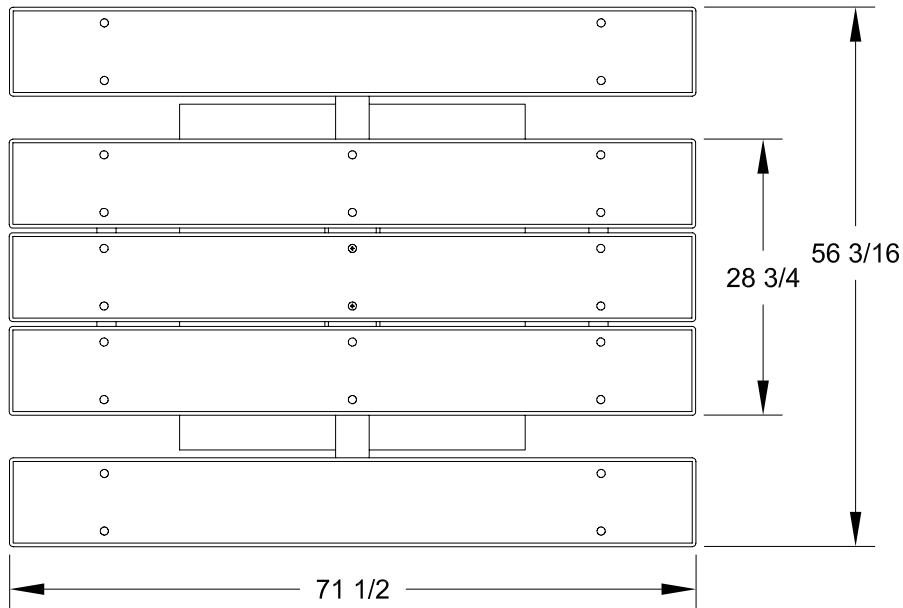

ALL DIMENSIONS IN INCHES

R. J. **THOMAS MFG. CO., INC.**  
P.O. Box 946 • Cherokee, IA 51012

DRAWN BY  
**WWM**

TITLE PT SERIES 6 FOOT EMBEDDED MOUNT RECTANGULAR SINGLE PEDESTAL TABLE  
WITH RECYCLED PLASTIC TOP AND SEAT PLANKS

DATE 01-27-06

DWG. NO. **AI-1714**