



*Model AT-6TP/E1 6 ft. Accessible A-Frame Rectangular Table with Treated Pine Legs Timbers and Top and Seat Planks*

- **Traditional A-Frame design**
- **Extended one foot on each end for wheelchair accessibility at both ends**
- **Sturdy 4" x 6" Treated #1 Southern Yellow Pine Legs**
- **Precision drilled, Treated #1 Southern Yellow Pine Seat and Top Planks**
- **Pregalvanized steel channel cross-member**
- **Quality construction throughout**

### **SPECIFICATIONS:**

- **AT Series** end frames shall be constructed from two 4" x 6" nominal sized timbers forming the legs of the "A" with ends cut at angles to provide firm contact with ground surface. Legs shall be connected at top by a 10 ga. x 2" x 2" formed pregalvanized steel angle which also provides attachment of table top planks. A formed pregalvanized 10 ga. x 1-3/4" x 4" steel channel connects legs at seat height and extends beyond legs to provide mounting and support for seat planks.
- Table shall be supported by diagonal braces of 1-5/16" O.D. pregalvanized steel pipe that shall connect to a die-formed steel channel designed to align and provide attachment to the table top.
- **Model AT-6TP/E1** shall have a nominal seat length of 72" and a nominal top length of 96".
- Table top shall extend 1 ft. beyond seats on each end to provide the ADA recommended wheelchair clearances of: 30" wide, 27" under table (ground to bottom of table top), and 24" total knee and toe clearance (19" + 5") at both ends.
- All 3/8" dia. galvanized carriage bolts and nuts shall be provided to fasten frames, supports, and top and seat planks together.
- **Standard:** Legs shall be 4" x 6" nominal sized Treated #1 grade Southern Yellow Pine. Top and seat planks shall be 2" x 10" nominal sized Treated #1 grade Southern Yellow Pine planks, kiln dried to reduce moisture content. All lumber shall be precision drilled to facilitate assembly and shall have all exposed edges removed to a 3/8" radius.

### **AVAILABLE OPTIONS**

**R.J. THOMAS MFG. CO., INC.**

**P.O. Box 946 • Cherokee, IA 51012-0946 • PH: 712-225-5115 • 800-762-5002 • FAX: 712-225-5796**

**E-mail: [pilotrock@rjthomas.com](mailto:pilotrock@rjthomas.com) • Web Site: <http://www.pilotrock.com>**

**© 2006 R. J. Thomas Mfg. Co., Inc. PILOT ROCK® Park Equipment is a registered trademark of R. J. Thomas Mfg. Co., Inc.**

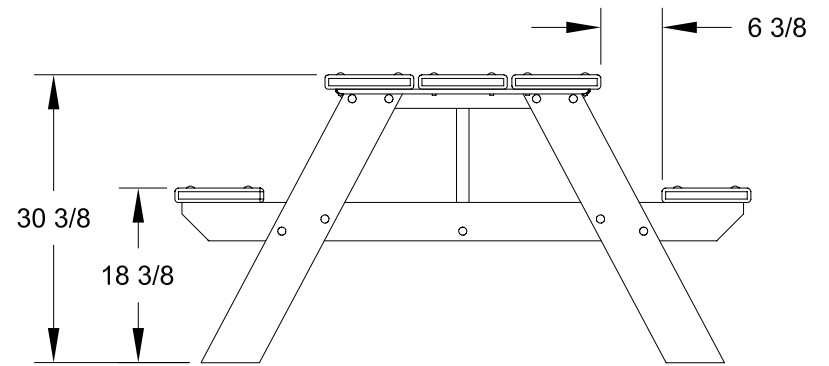
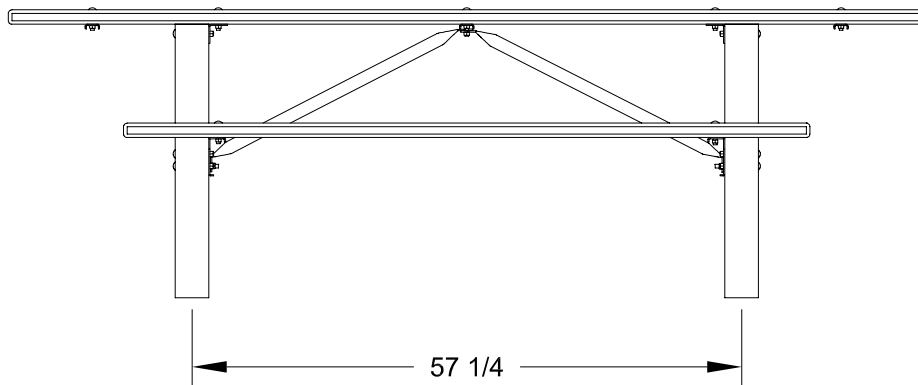
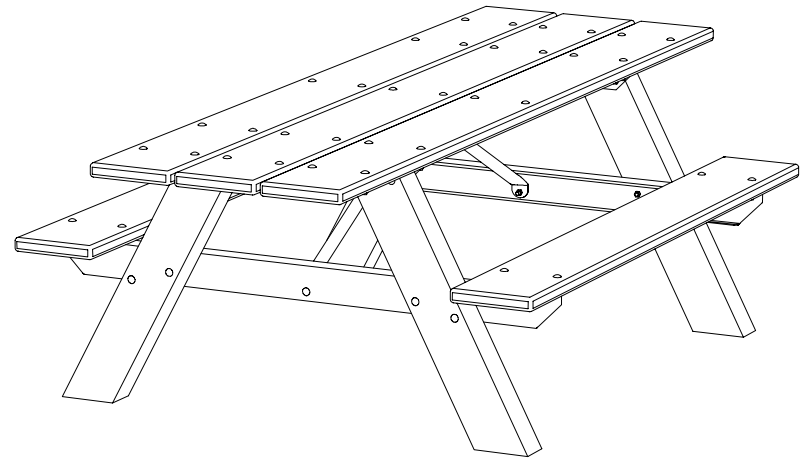
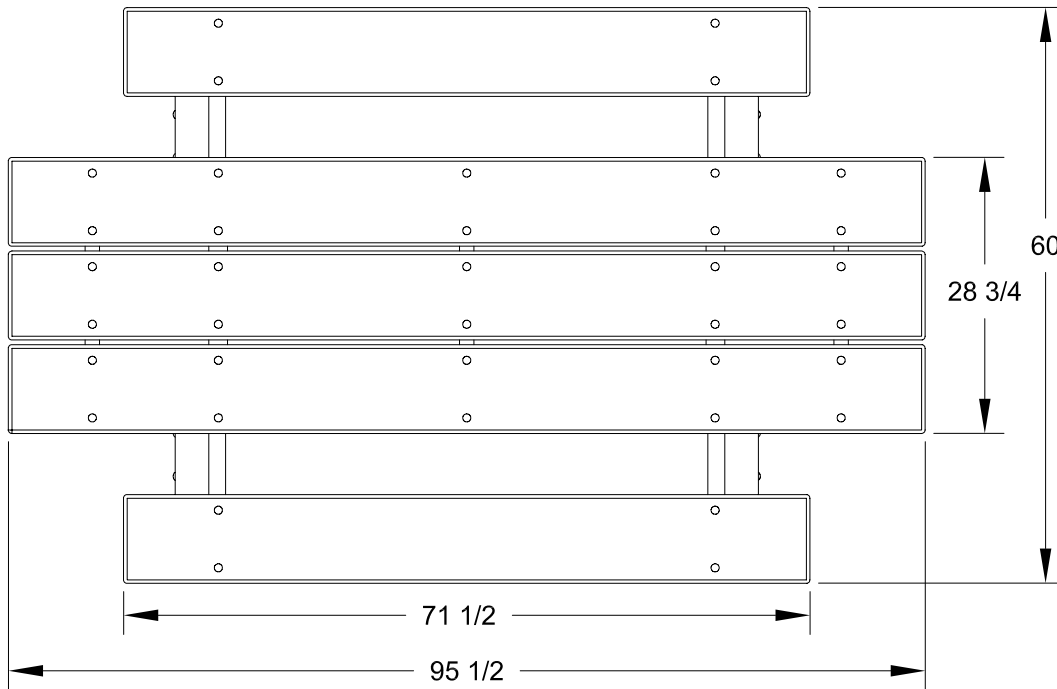

ALL DIMENSIONS IN INCHES

R. J. **THOMAS MFG. Co., INC.**  
P.O. Box 946 • Cherokee, IA 51012

DRAWN BY  
**WWM**

TITLE AT SERIES 6 FOOT WHEELCHAIR ACCESSIBLE A-FRAME TABLE EXTENDED  
1 FOOT ON BOTH ENDS WITH LUMBER TIMBERS AND PLANKS

DATE 01-31-06

DWG. NO. **AI-1716**