



*Model UTK/G-4UP 4 ft. children's Rectangular Table
with Hot Dip Galvanized frames
and Untreated Pine top and seat planks*

- **Scaled to fit children up to 12 years of age**
- **Nontip, nontrip, walk-through design**
- **Strong 1-5/8" diameter all welded, steel pipe end frame construction**
- **Precision drilled, Untreated #1 Southern Yellow Pine seat and top planks**
- **Frames are hot-dip galvanized after fabrication for superior corrosion resistance**
- **Diagonal bracing for strength and rigidity**
- **Die-formed center channel under table top to support and align top planks**
- **Simple bolt together assembly with all 3/8" dia. galvanized carriage bolts included**
- **Limited Lifetime Warranty on frames**

AVAILABLE OPTIONS

- 4, 6, or 8 foot lengths
- Powder Coat Finish in choice of colors or Black Enamel Painted steel frame components
- Pressure treated #1 Southern Yellow Pine lumber (Cedar, Fir, or Redwood lumber when in stock)

SPECIFICATIONS:

- **UTK Series** end frames shall be one-piece welded construction, fabricated from 1.660" O.D. (1-5/8" O.D.) steel pipe to meet 1-1/4" nominal pipe size specifications with 2" x 2" x 3/16" A-36 structural grade steel angle for attaching the seats and tops.
- Table frame design shall incorporate nontip, nontrip, walk-through design features. Bends shall be tightly formed to prevent tipping when weight is on one side.
- Nominal table height shall be 22". Nominal seat height shall be 12".
- **Model UTK/G-4** shall have a 4 ft. nominal length.
- **Model UTK/G-6** shall have a 6 ft. nominal length.
- **Model UTK/G-8** shall have a 8 ft. nominal length.
- Frames shall be supported by diagonal braces of 1-5/16" O.D. steel pipe that shall connect to a die-formed steel channel designed to align and provide attachment to the table top.
- All 3/8" dia. galvanized carriage bolts and nuts shall be provided to fasten frames and center channel to lumber.
- **Standard:** Frames, diagonal braces, and center channel shall be hot-dip galvanized after fabrication to ASTM-A123 to maintain an average zinc coating of 2.0 oz. per sq. ft. of surface area (indicated by "/G" in model no.).
- **Standard:** Lumber shall be Untreated #1 grade Southern Yellow Pine (indicated by "UP" in model no.) 2" x 10" nominal sized planks, kiln dried to reduce moisture content. All lumber shall be precision drilled to facilitate assembly and shall have all exposed edges removed to a 3/8" radius.
- **Optional:** Frames, diagonal braces and center channel shall be finished in black enamel. To specify, change "/G" to "/B" in model no., e.g. UTK/B-6UP.
- **Optional:** Color choices of powder coated steel frame components. For optional colors choices see Specification Bulletin # SPC-CO-001.
- **Optional:** Treated #1 Southern Yellow Pine is readily available and shall be pressure treated and kiln dried after treatment (KDAT) to preserve wood against decay. To specify, change "UP" in model no. to "TP", e.g. UTK/G-6TP. (Cedar, Fir, and Redwood are available when in stock – please inquire.)

R.J. THOMAS MFG. CO., INC.

P.O. Box 946 • Cherokee, IA 51012-0946 • PH: 712-225-5115 • 800-762-5002 • FAX: 712-225-5796

E-mail: pilotrock@rjthomas.com • Web Site: <http://www.pilotrock.com>

© 2007 R. J. Thomas Mfg. Co., Inc. PILOT ROCK® Park Equipment is a registered trademark of R. J. Thomas Mfg. Co., Inc.

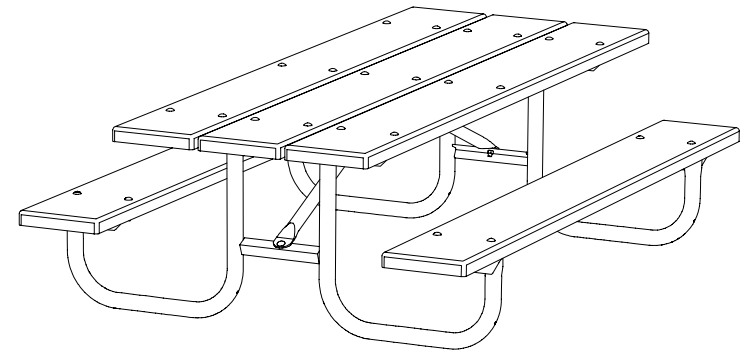
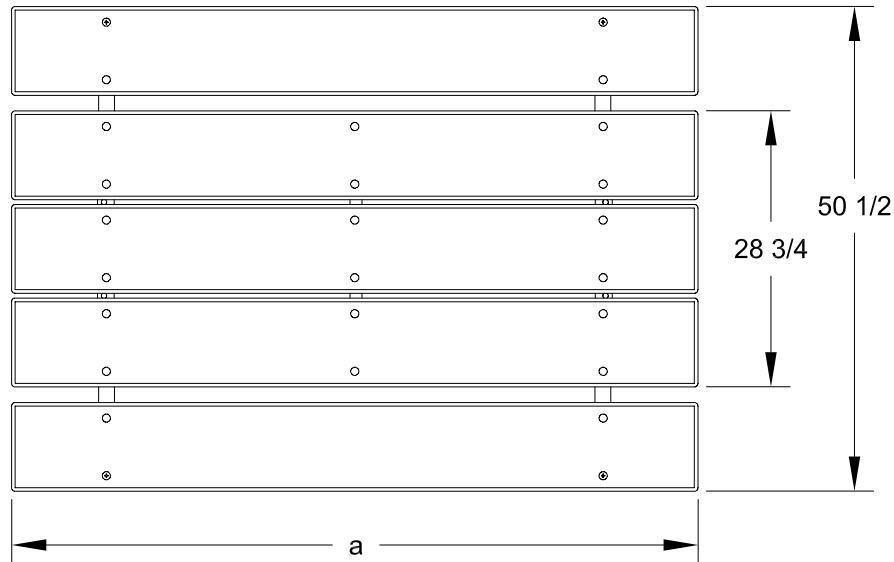

MODEL NUMBER	DIMENSION	
	a	b
UTK-4	47-1/2	30
UTK-6	71-1/2	51-3/4
UTK-8	95-1/2	70

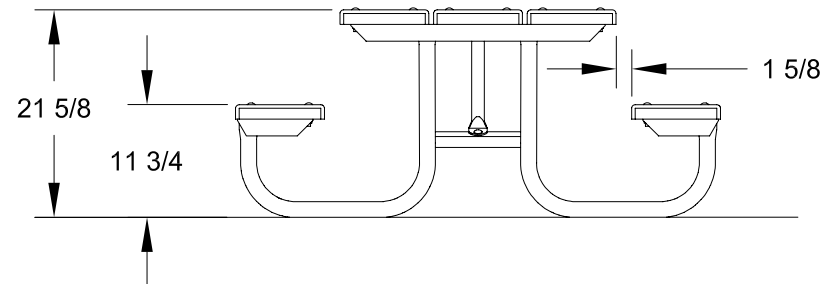
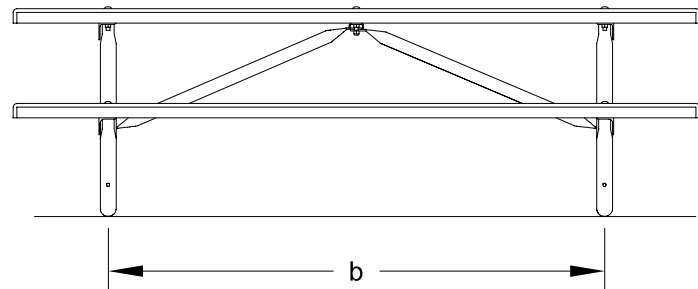

ALL DIMENSIONS IN INCHES

R. J. **THOMAS MFG. Co., Inc.**
P.O. Box 946 • Cherokee, IA 51012

DRAWN BY
WWM

TITLE UTK SERIES 4, 6, AND 8 FOOT CHILDRENS RECTANGULAR PORTABLE TABLE
WITH LUMBER TOP AND SEAT PLANKS

DATE 1-11-07

DWG. NO. **AI-1748**