



*Model UTK/CR-6PU 6 ft. Children's Rectangular Table
with Red powder coated frames
and Blue recycled plastic top and seat planks*

- **Scaled to fit children up to 12 years of age**
- **Nontip, nontrip, walk-through design**
- **Strong 1-5/8" diameter all welded, steel pipe end frame construction**
- **100% Recycled Plastic Seat and Top Planks**
- **Solid color throughout plastic and U.V. stabilizer for ultraviolet protection**
- **Pregalvanized steel channel reinforcements under seats and table top**
- **Frames are hot-dip galvanized after fabrication for superior corrosion resistance**
- **Diagonal bracing for strength and rigidity**
- **Die-formed center channel under table top to support and align top planks**
- **Simple bolt together assembly with all 3/8" dia. galvanized carriage bolts included**
- **Limited Lifetime Warranty on frames**

AVAILABLE OPTIONS

- 4, 6, or 8 foot lengths
- Powder Coat Finish in choice of colors or Black Enamel Painted steel frame components
- Choice of colors of Recycled Plastic

SPECIFICATIONS:

- **UTK Series** end frames shall be one-piece welded construction, fabricated from 1.660" O.D. (1-5/8" O.D.) steel pipe to meet 1-1/4" nominal pipe size specifications with 2" x 2" x 3/16" A-36 structural grade steel angle for attaching the seats and tops.
- Table frame design shall incorporate nontip, nontrip, walk-through design features. Bends shall be tightly formed to prevent tipping when weight is on one side.
- Nominal table height shall be 22". Nominal seat height shall be 12".
- **Model UTK/G-4** shall have a 4 ft. nominal length.
- **Model UTK/G-6** shall have a 6 ft. nominal length.
- **Model UTK/G-8** shall have a 8 ft. nominal length.
- Frames shall be supported by diagonal braces of 1-5/16" O.D. steel pipe that shall connect to a die-formed steel channel designed to align and provide attachment to the table top.
- All 3/8" dia. galvanized carriage bolts and nuts shall be provided to fasten frames and center channel to planks.
- **Standard:** Frames, diagonal braces, and center channel shall be hot-dip galvanized after fabrication to ASTM-A123 to maintain an average zinc coating of 2.0 oz. per sq. ft. of surface area (indicated by "/G" in model no.).
- **Standard:** Tops and seats shall be made of 100% Recycled Plastic molded into 2" x 10" nominal sized planks with solid Cedar colored (indicated by "PC" in model no.) formed throughout and a U.V. stabilizer added for ultra-violet protection.
- Table tops and seats shall be supported by pregalvanized steel subframe channels.
- **Optional:** Frames, diagonal braces, reinforcing channels, and center channel shall be finished in black enamel. To specify, change "/G" to "/B" in model no., e.g. UTK/B-6PC.
- **Optional:** Color choices of powder coated steel frame components. For optional colors choices see Specification Bulletin # SPC-CO-001.
- **Optional:** Color choices of Recycled Plastic components. For optional colors choices see Specification Bulletin # SPC-CO-001.

R.J. THOMAS MFG. CO., INC.

P.O. Box 946 • Cherokee, IA 51012-0946 • PH: 712-225-5115 • 800-762-5002 • FAX: 712-225-5796

E-mail: pilotrock@rjthomas.com • Web Site: <http://www.pilotrock.com>

© 2007 R. J. Thomas Mfg. Co., Inc. PILOT ROCK® Park Equipment is a registered trademark of R. J. Thomas Mfg. Co., Inc.

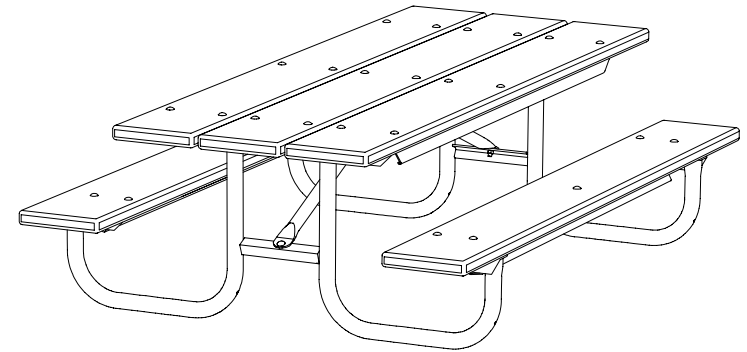
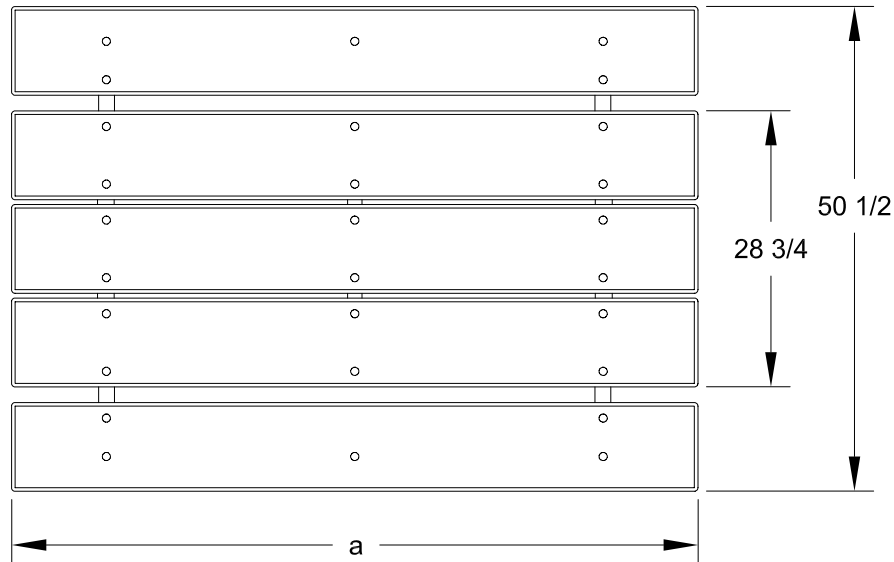

MODEL NUMBER	DIMENSION	
	a	b
UTK-4	47-1/2	30
UTK-6	71-1/2	51-3/4
UTK-8	95-1/2	70

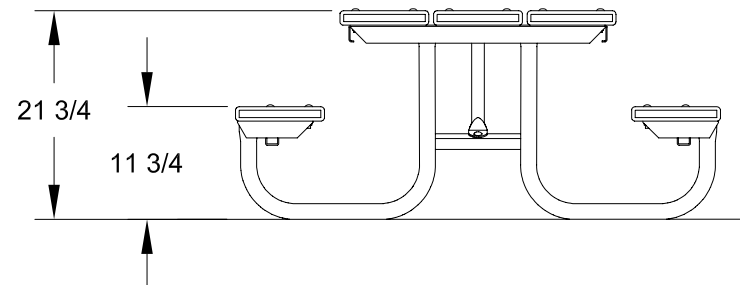
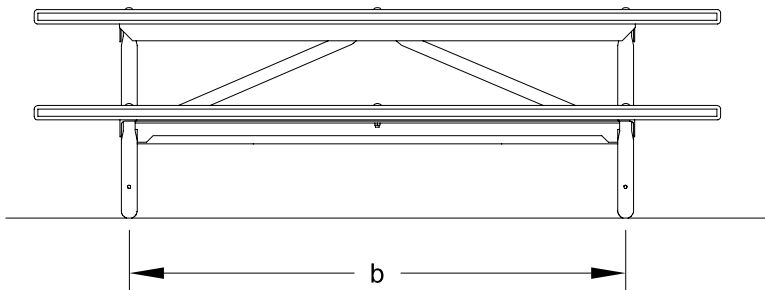

ALL DIMENSIONS IN INCHES

R. J. **THOMAS MFG. Co., Inc.**
P.O. Box 946 • Cherokee, IA 51012

DRAWN BY
WWM

TITLE UTK SERIES 4, 6, AND 8 FOOT CHILDRENS RECTANGULAR PORTABLE TABLE
WITH RECYCLED PLASTIC TOP AND SEAT PLANKS

DATE 1-19-07

DWG. NO. **AI-1750**