

*Model APTX/G-6DU 6 ft. Rectangular Embedded Mount
Table with Hot Dip Galvanized Frames and Blue D-Type
Plastisol Coated Expanded Steel Top*

- **Permanent embedded mounting**
- **Sturdy 3" x 6" rectangular steel tube pedestals**
- **Frames are hot-dip galvanized after fabrication for superior corrosion resistance**
- **Plastisol Coating heat fused to Expanded Steel Top for durability**
- **Quality construction throughout**

SPECIFICATIONS:

- **APTX Series** Table top end frames shall be one-piece welded construction, fabricated from 3" x 6" x 1/8" wall rectangular structural steel tubing with 2" x 2" x 3/16" A-36 structural grade steel angle for attaching the top. Exposed ends of rectangular tubing shall be permanently sealed with welded-on steel end caps. Frames are designed to be embedded in a concrete footing.
- Model **APTX/G-6** shall have a nominal length of 72".
- Model **APTX/G-8** shall have a nominal length of 96".
- Nominal table height shall be 32".
- All galvanized carriage bolts and nuts shall be provided for table assembly.
- **Standard:** All frame components shall be hot-dip galvanized after fabrication to ASTM-A123 to maintain an average zinc coating of 2.0 oz. per sq. ft. of surface area (indicated by "/G" in model no.).
- **D-Type** table top shall be a one-piece welded construction, fabricated from a 3/4-#9 expanded steel surface with 2" roll-formed 14 ga. steel vertical edges on all sides and reinforced by a strap and die-formed angle substructure.
- **Standard:** All steel surfaces of the top shall be covered with a coating of Brown vinyl Plastisol (indicated by "DW" in model no.) formulated with high impact additives, UV inhibitors, and an anti-microbial to resist mold and mildew. Plastisol coating shall be permanently heat-fused to the steel to an average thickness of 125 mils (1/8") for an overall average thickness, including top and bottom coatings, of 250 mils (1/4").
- **Optional:** Color choices of plastisol coated steel components. For optional colors choices see Specification Bulletin # SPC-CO-001.
- **Optional:** Color choices of powder coated steel frame components. For optional colors choices see Specification Bulletin # SPC-CO-001.
- **Optional:** Frames shall be provided with a 3/8" x 8" x 8" steel base plates to bolt table posts to existing concrete pad. To specify add "/P" after the "APTX" in the model no., e.g. APTX/P/G-6DW. (Anchor bolts not included.)

AVAILABLE OPTIONS

- **6 or 8 foot lengths**
- **Powder Coat Finish in choice of colors for steel frame components**
- **Choice of colors of Plastisol Coating**
- **Surface mount base plate**

RJThomas Mfg. Co., Inc.

PO Box 946 • Cherokee, IA 51012-0946 • PH: 712-225-5115 • 800-762-5002 • FAX: 712-225-5796
E-mail: pilotrock@rjthomas.com • Web Site: <http://www.pilotrock.com>

© 2008 RJThomas Mfg. Co., Inc. PILOT ROCK® Park Products is a registered trademark of RJThomas Mfg. Co., Inc.

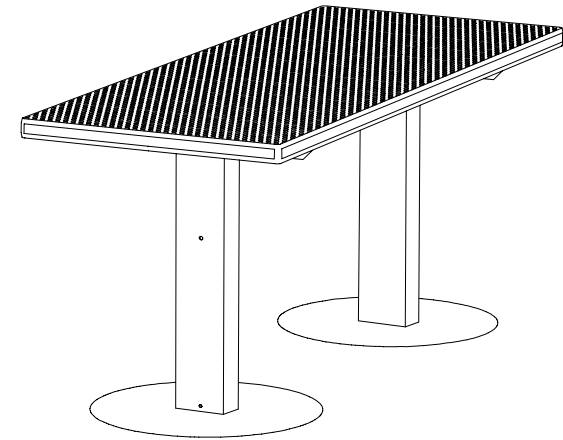
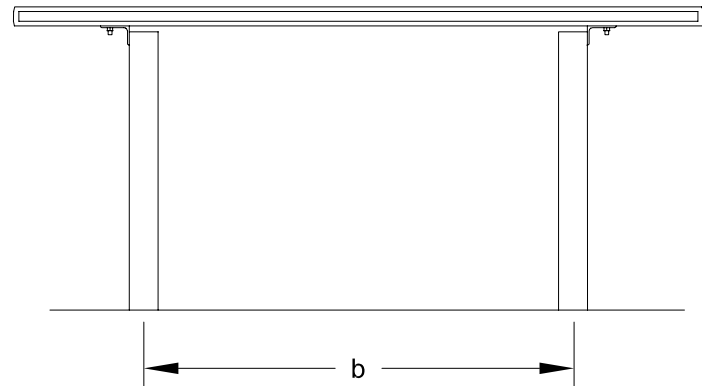
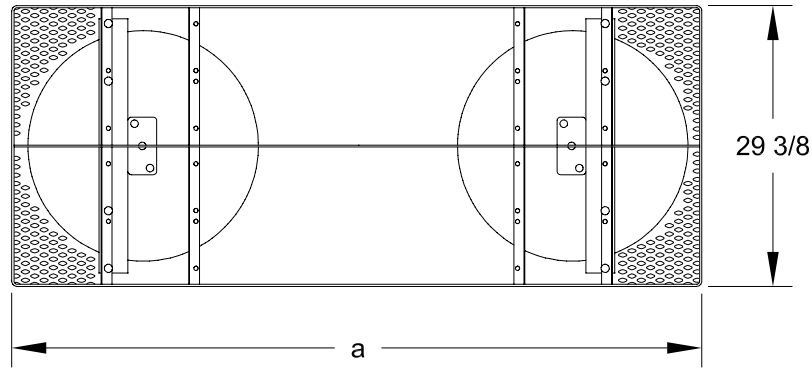

MODEL NUMBER	DIMENSION	
	a	b
APT-X-6	72	44-3/4
APT-X-8	96	63

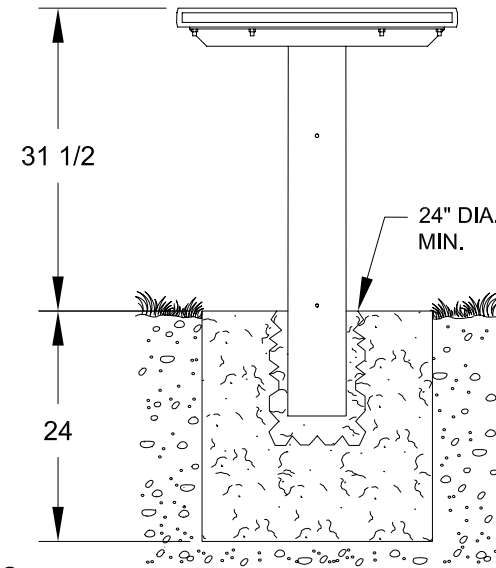

NOTE:
LOCAL SOIL
CONDITIONS
MAY REQUIRE
A LARGER
FOOTING
(CHECK LOCAL
CODES)

ALL DIMENSIONS IN INCHES

R. J. **THOMAS MFG. Co., INC.**
P.O. Box 946 • Cherokee, IA 51012

DRAWN BY
WWM

TITLE APTX SERIES 6 AND 8 FOOT EMBEDDED MOUNT RECTANGULAR DOUBLE
PEDESTAL UTILITY TABLE WITH D-TYPE PLASTISOL COATED
EXPANDED STEEL TOP

DATE 4-30-07

DWG. NO. **AI-1778**