

Silver Sioux Series, Model B40C Surface Mount 8 Ft. Bench with Lumber Timbers



*Model B40C/CB-8IB34 8 Ft. Surface Mount Bench
with Black Powder Coat Frames
and Indonesian Balau Wood 3" x 4" Timbers.*

- **Comfortable seat design may be accessed from either side**
- **Stylish armrest loops integrated into end frames**
- **Sturdy, formed and welded steel frame construction**
- **Powder Coat frame finish**
- **Precision drilled Hardwood 3" x 4" Timbers**
- **Quality construction throughout**

SPECIFICATIONS:

- **Model B40C-8** shall be a nom. 8 ft. in length.
- **Model B40C Series** end frames shall be one-piece welded construction with frame leg and foot to meet 1-1/2" nominal steel pipe size specifications (1-7/8" O.D.). Frame foot shall be die-formed with flattened and rounded ends, with a 9/16" dia. anchor hole in each end. Seat bracket shall be constructed of 3/8" x 2-1/2" A-36 flat steel bar with holes to mount four 3" x 4" timbers. The end frames shall include a welded-on circular armrest formed from 1.66" O.D. steel tubing.
- Benches shall be permanently surface mounted using 9/16" dia. holes provided in each frame foot for use with concrete anchors (anchors not included).
- Bench shall be provided with a center frame for additional support (indicated by "B40C" in model no., e.g. B40C/CB-8IB34). Center frame does not have armrest.
- **Standard:** Frames shall be finished in Black powder coat (indicated by "/CB" in model no., e.g. B40C/CB-8IB34).
- **Standard:** Lumber shall be Indonesian Balau Wood 3" x 4" nominal sized timbers (indicated by "IB" in model no., e.g. B40C/CB-8IB34). All timbers shall be precision drilled for fast, easy assembly and shall have all exposed edges removed to a 3/8" radius with a bullnose profile timber used on outside positions.
- All galvanized fasteners shall be provided for assembly.
- **Optional:** Color choices of powder coated steel frame components. For optional colors choices see Specification Bulletin #SPC-CO-001.
- **Optional:** Lumber shall be #1 grade Southern Yellow Pine, pressure treated and kiln dried after treatment (KDAT) to preserve wood against decay, or Construction Heart Redwood. (To specify, change "IB" in model no. to "TP" for Treated Pine, e.g. B40C/CB-8TP34, or to "CO" for Construction Heart Redwood, e.g. B40C/CB-8CO34.)

AVAILABLE OPTIONS

- **Choice of colors of Powder Coat Finish on steel frame components**
- **Treated #1 Southern Yellow Pine or Construction Heart Redwood lumber**
- **Custom Lettering and Plaques available (call for details)**

RJThomas Mfg. Co., Inc.

PO Box 946 • Cherokee, IA 51012-0946 • PH: 712-225-5115 • 800-762-5002 • FAX: 712-225-5796
E-mail: pilotrock@rjthomas.com • Web Site: <http://www.pilotrock.com>

© 2008 RJThomas Mfg. Co., Inc. PILOT ROCK® Park Products is a registered trademark of RJThomas Mfg. Co., Inc.

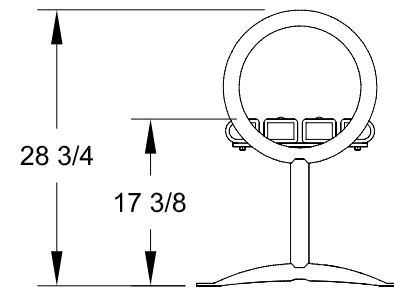
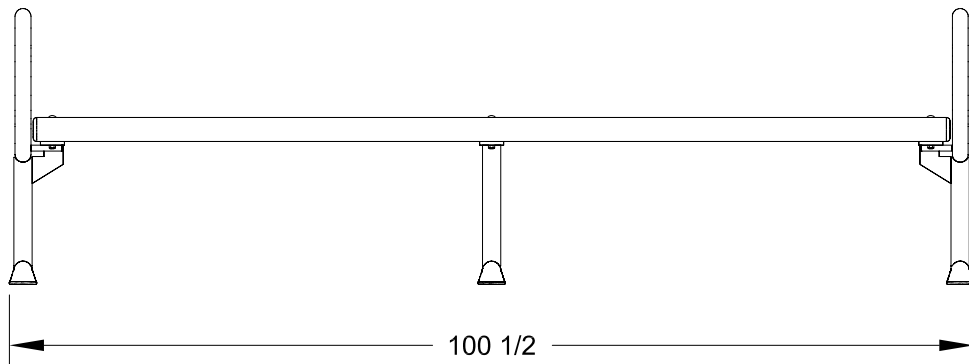
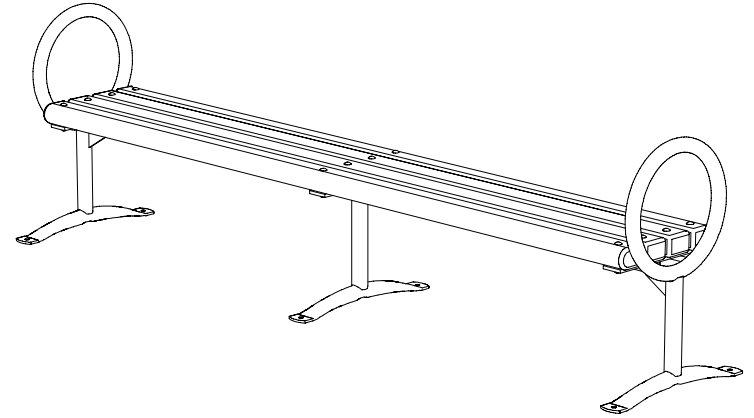
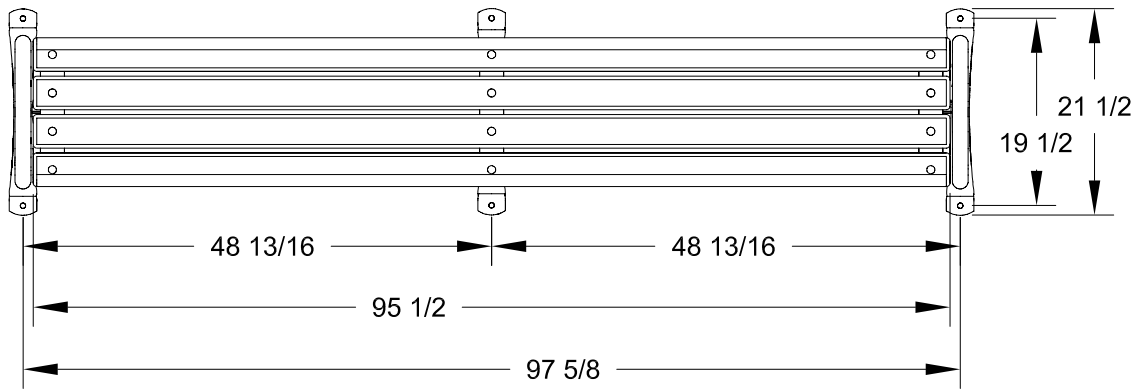

ALL DIMENSIONS IN INCHES

R. J. **THOMAS MFG. Co., INC.**
P.O. Box 946 • Cherokee, IA 51012

DRAWN BY
WWM

TITLE SILVER SIOUX SERIES, MODEL B40C 8 FOOT FLAT SURFACE MOUNT
BENCH WITH 3" X 4" LUMBER TIMBERS

DATE 1-08-04

DWG. NO. **AI-1528**