



Model BE40/CW-3IB34 3 Ft. Surface Mount Bench Extension with Brown Powder Coat Frames and Indonesian Balau Wood 3" x 4" Timbers. (Shown with Model B40/CW-3IB34 Bench.)

- **Comfortable seat design may be accessed from either side**
- **Designed to join easily with Model B40 benches to make longer benches with additional armrests**
- **Stylish armrest loops integrated into extension frames**
- **Sturdy, formed and welded steel frame construction**
- **Powder Coat frame finish**
- **Precision drilled Hardwood 3" x 4" Timbers**
- **Quality construction throughout**

SPECIFICATIONS:

- **Model BE40-3** shall be a nom. 3 ft. in length.
- **Model BE40-4** shall be a nom. 4 ft. in length.
- Model BE40 bench extensions shall be used with Model B40 3 and 4 ft. benches. Multiple extensions can be added to create any length of bench in 3 and 4 ft. increments. The extension frame replaces one bench end frame which is then moved to the end of the extension. (For information on Model B40 benches refer to Specification Bulletin #SPC-BC-025.)
- **Model BE40 Series** extension frame shall be one-piece welded construction with frame leg and foot to meet 1-1/2" nominal steel pipe size specifications (1-7/8" O.D.). Frame foot shall be die-formed with flattened and rounded ends, with a 9/16" dia. anchor hole in each end. Two seat brackets shall be constructed of 3/8" x 2-1/2" A-36 flat steel bar with holes to mount four 3" x 4" timbers. The extension frame shall include a welded-on circular armrest formed from 1.66" O.D. steel tubing.
- Extensions shall be permanently surface mounted using 9/16" dia. holes provided in each frame foot for use with concrete anchors (anchors not included).
- **Standard:** Frames shall be finished in Black powder coat (indicated by "/CB" in model no., e.g. BE40/CB-3IB34).
- **Standard:** Lumber shall be Indonesian Balau Wood 3" x 4" nominal sized timbers (indicated by "IB" in model no., e.g. BE40/CB-3IB34). All timbers shall be precision drilled for fast, easy assembly and shall have all exposed edges removed to a 3/8" radius with a bullnose profile timber used on outside positions.
- All galvanized fasteners shall be provided for assembly.
- **Optional:** Color choices of powder coated steel frame components. For optional colors choices see Specification Bulletin #SPC-CO-001.
- **Optional:** Lumber shall be #1 grade Southern Yellow Pine, pressure treated and kiln dried after treatment (KDAT) to preserve wood against decay, or Construction Heart Redwood. (To specify, change "IB" in model no. to "TP" for Treated Pine, e.g. BE40/CB-3TP34, or to "CO" for Construction Heart Redwood, e.g. BE40/CB-3CO34).

AVAILABLE OPTIONS

- **3' or 4' models**
- **Choice of colors of Powder Coat Finish on steel frame components**
- **Treated #1 Southern Yellow Pine or Construction Heart Redwood lumber**
- **Custom Lettering and Plaques available (call for details)**

RJThomas Mfg. Co., Inc.

PO Box 946 • Cherokee, IA 51012-0946 • PH: 712-225-5115 • 800-762-5002 • FAX: 712-225-5796
E-mail: pilotrock@rjthomas.com • Web Site: <http://www.pilotrock.com>

© 2008 RJThomas Mfg. Co., Inc. PILOT ROCK® Park Products is a registered trademark of RJThomas Mfg. Co., Inc.

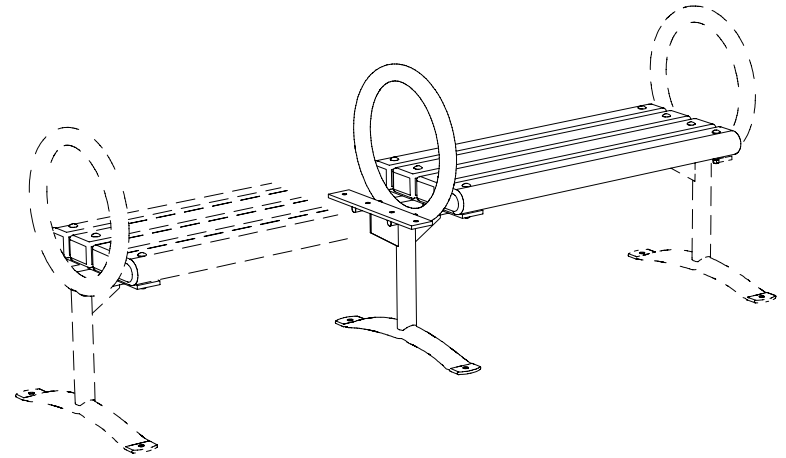
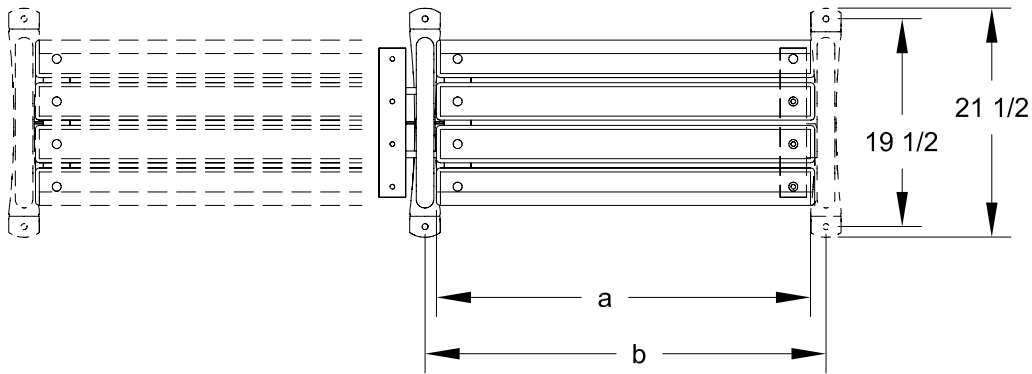

MODEL NUMBER	DIMENSION		
	a	b	c
BE40-3	35 1/2	37 5/8	37 5/8
BE40-4	47 1/2	49 5/8	49 5/8

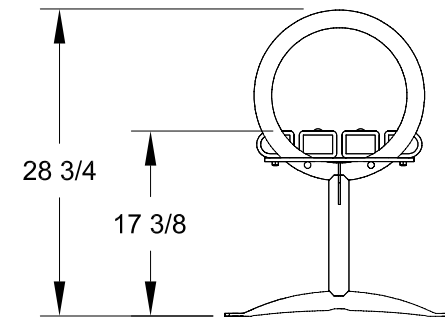
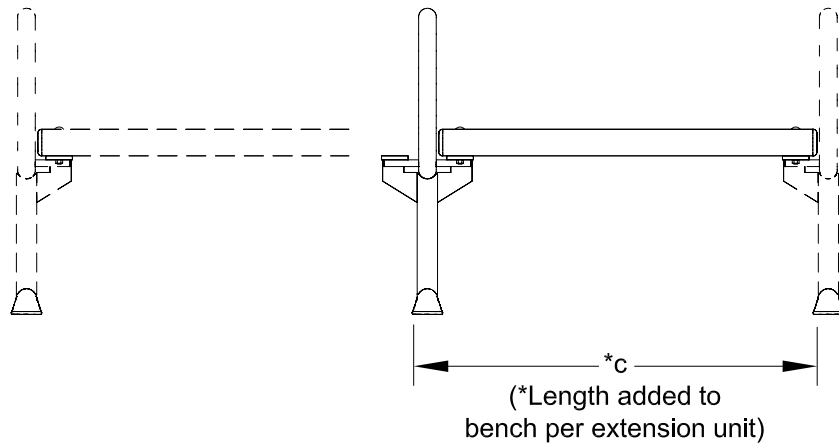

ALL DIMENSIONS IN INCHES

R. J. **THOMAS MFG. Co., INC.**
P.O. Box 946 • Cherokee, IA 51012

DRAWN BY
WWM

TITLE SILVER SIOUX SERIES MODEL BE40 3 AND 4 FOOT FLAT, SURFACE MOUNT BENCH
EXTENSION WITH 3" X 4" LUMBER TIMBERS (SHOWN WITH SILVER SIOUX SERIES MODEL
B40 BENCH IN PHANTOM)

DATE 1-13-04

DWG. NO. **AI-1530**