

Model SCXB3/G-15AL Embedded Mount Bench
*with Hot-Dip Galvanized Frames, 15 Ft. long
with Aluminum back and seat.*

- **Extra heavy design to be stronger and more stable with a simple, clean style.**
- **Sturdy, formed and welded steel frame construction**
- **Frames are Hot-Dip Galvanized after fabrication for superior corrosion resistance**
- **Structurally reinforced extruded Aluminum Seats with anodized finish**
- **Quality construction throughout**

SPECIFICATIONS:

- **Model SCXB** end frames shall be one-piece, welded construction with a back and seat bracket of 2-3/8" x 1-1/2" x 1/8" nominal sized, die-formed channel, and a 2.375" (2-3/8") O.D. post to meet 2" nominal steel pipe size specifications. Bench legs shall be permanently embedded in concrete footings.
- **Model SCXB3/G-15AL** shall be 15 ft. long (nom.) with three frames.
- **Model SCXB5/G-21AL** shall be 21 ft. long (nom.) with five frames.
- **Model SCXB5/G-24AL** shall be 24 ft. long (nom.) with five frames.
- **Standard:** Frames shall be hot-dip galvanized after fabrication to ASTM-A123 to maintain an average zinc coating of 2.0 oz. per sq. ft. of surface area (indicated by "/G" in model no.).
- Aluminum shall be extruded 6063-T6 aluminum alloy in planks with dimensions equivalent to that of 2" x 10" nominal sized lumber. The plank design shall be 1-3/4" x 9-5/8" with four structural reinforcement ribs for greater rigidity. Aluminum planks shall be provided with a clear anodized finish as per anodizing specification 204 R1.
- Channel end caps shall be of extruded 6063-T6 aluminum alloy provided with a clear anodized finish as per anodizing specification 204 R1. End caps shall be press fitted over ends of aluminum planks and shall be mechanically fastened in place at the factory.
- Aluminum planks shall be provided with galvanized carriage bolts, nuts, and precision fitted aluminum brackets to fasten planks to bench frames.
- **Optional:** Color choices of powder coated steel frame components. For optional colors choices see Specification Bulletin # SPC-CO-001.
- **Optional:** Color choices of powder coated aluminum seat and back planks, and end caps. For optional colors choices see Specification Bulletin # SPC-CO-001.

AVAILABLE OPTIONS



- 15', 21', or 24' models
Powder Coat Finish in choice of colors for Steel
Frame components
Powder Coat Finish in choice of colors for Aluminum
seat and back

RJThomas Mfg. Co., Inc.

PO Box 946 • Cherokee, IA 51012-0946 • PH: 712-225-5115 • 800-762-5002 • FAX: 712-225-5796
E-mail: pilotrock@rjthomas.com • Web Site: <http://www.pilotrock.com>

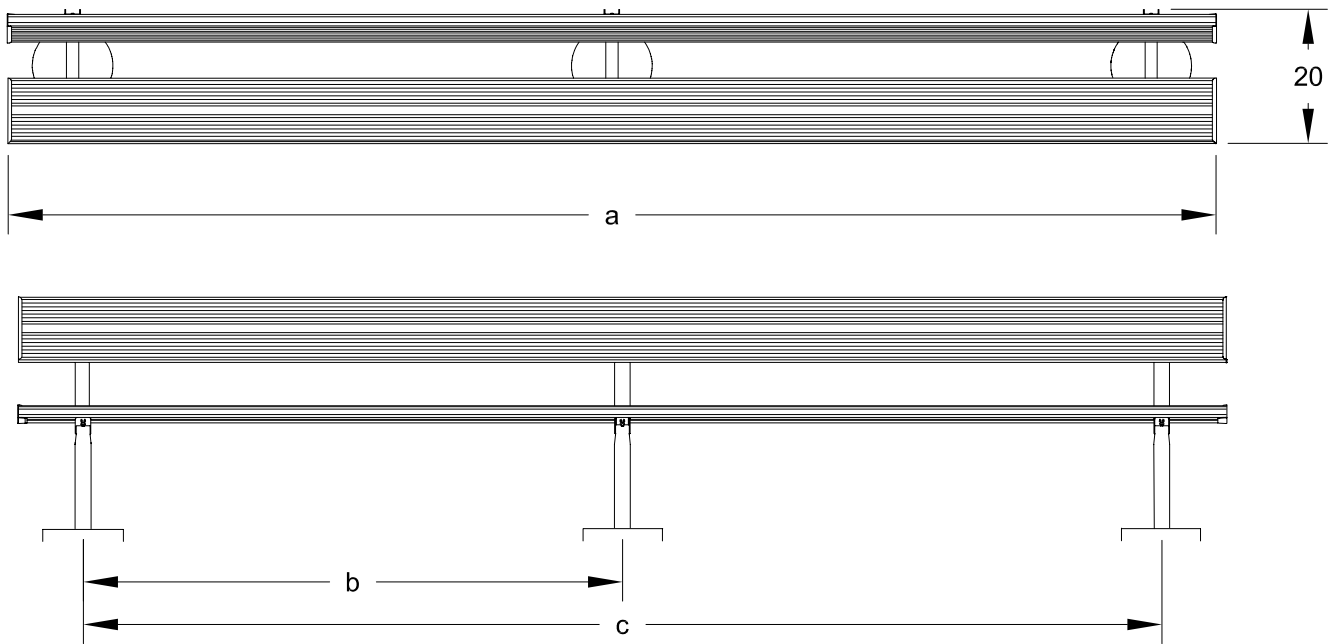
© 2008 RJThomas Mfg. Co., Inc. PILOT ROCK® Park Products is a registered trademark of RJThomas Mfg. Co., Inc.

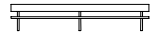

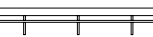
MODEL NUMBER	DIMENSION			NO. OF FRAMES
	a	b	c	
SCXB3-15	180	80 1/4	160 1/2	3 
SCXB5-21	252	60	240	5 
SCXB5-24	288	70	280	5 

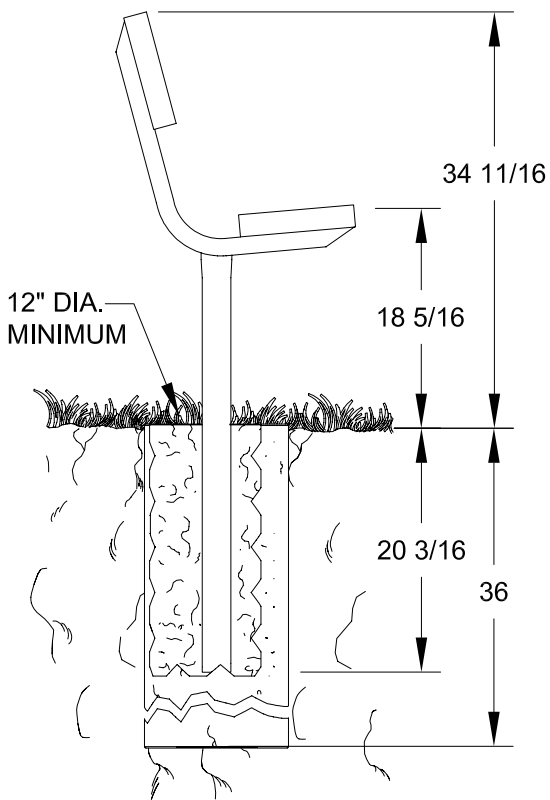

NOTE:
LOCAL SOIL
CONDITIONS
MAY REQUIRE
A LARGER
FOOTING
(CHECK LOCAL
CODES)

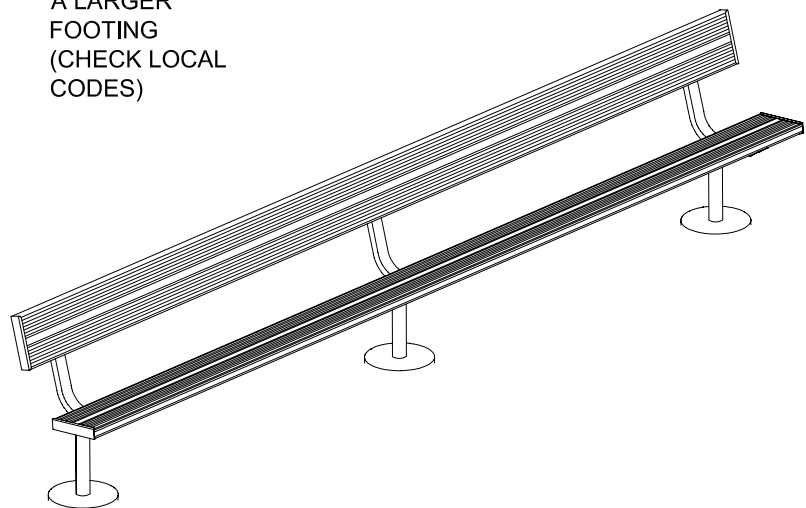

ALL DIMENSIONS IN INCHES

R.J. **THOMAS MFG.**
Co., INC.
P.O. Box 946
Cherokee, IA 51012

TITLE MODEL SCXB EXTRA HEAVY DUTY 15, 21, AND 24 FOOT
EMBEDDED MOUNT BENCH WITH ALUMINUM SEAT AND BACK

DRAWN BY **WWM**

DATE **2-22-07**

DWG. NO. **AI-1769**