



*Model B82/CR-6SP Surface Mount Contour Bench
with Red Powder Coat Finish, 6 Ft. long.*

- **Comfortable decoratively cut steel plate contour seat design**
- **Frame curves form comfortable armrests**
- **Sturdy cast iron end frames. Formed and welded steel seat and brace components**
- **Powder Coat finish**
- **Easy bolt together assembly**
- **Quality construction throughout**

SPECIFICATIONS:

- **Model B82** end frames shall be one-piece molded cast iron construction.
- **Model B82-4** shall be a nom. 4 ft. in length.
- **Model B82-6** shall be a nom. 6 ft. in length.
- **Model B82-8** shall be a nom. 8 ft. in length.
- Frames shall be supported by a horizontal brace of 1.9" O.D. x 11 ga. wall steel pipe.
- **Standard:** Seat shall be a one piece assembly made of a decorative horizontal diamond pattern cut into a 10 ga. thick steel plate welded to 7 ga. end plates. Front and top edges shall have a 1-13/16" radius roll to form a smooth curved outer edge of seat.
- Benches shall be permanently surface mounted using 9/16" dia. holes provided in each leg foot for use with anchors (anchors not included).
- **Standard:** Frames, braces, and seat shall be finished in Black powder coat (indicated by "/CB" in model no.).
- All stainless steel fasteners shall be provided for assembly.
- **Optional:** Color choices of powder coated finish. For optional colors choices see Specification Bulletin #SPC-CO-001.
- **Optional:** Anchor kit **ANC4-4** with four 1/2" x 3-3/4" wedge anchors.
- **Optional:** Custom lettering cut into the backrest area is available, please inquire for details.

AVAILABLE OPTIONS

- **4', 6', or 8' models**
- **Choice of colors of Powder Coat Finish**

RJThomas Mfg. Co., Inc.

PO Box 946 • Cherokee, IA 51012-0946 • PH: 712-225-5115 • 800-762-5002 • FAX: 712-225-5796
E-mail: pilotrock@rjthomas.com • Web Site: <http://www.pilotrock.com>

© 2008 RJThomas Mfg. Co., Inc. PILOT ROCK® Park Products is a registered trademark of RJThomas Mfg. Co., Inc.

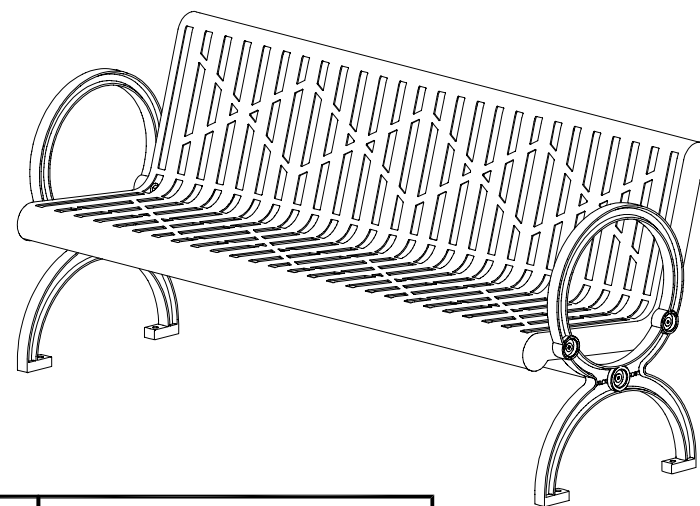
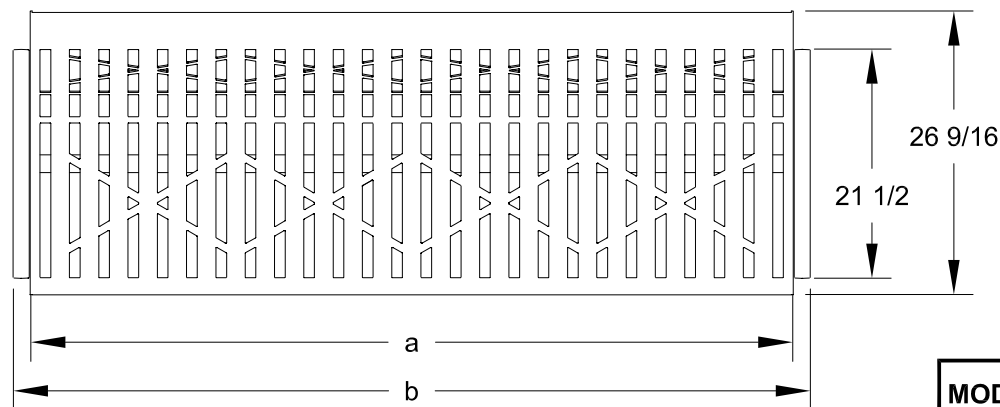

MODEL NUMBER	DIMENSION		
	a	b	c
B82-4	47 1/2	50 3/4	49 1/4
B82-6	71 1/2	74 3/4	73 1/4
B82-8	95 1/2	98 3/4	97 1/4

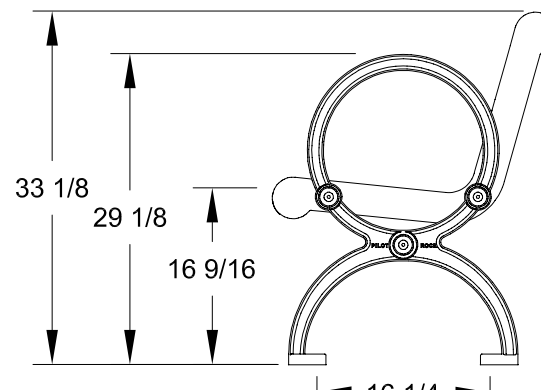
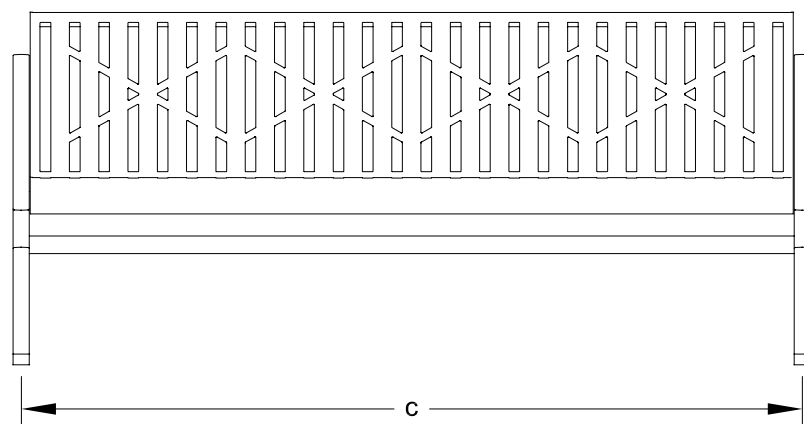

CENTER TO CENTER
OF MOUNTING HOLES

ALL DIMENSIONS IN INCHES

CENTER TO CENTER
OF MOUNTING HOLES

R. J. **THOMAS MFG. Co., INC.**
P.O. Box 946 • Cherokee, IA 51012

DRAWN BY
WWM

TITLE **GILLETTE SERIES MODEL B82 4, 6, AND 8 FOOT CONTOUR SURFACE MOUNT
BENCH WITH CAST IRON END FRAMES AND STEEL PLATE SEAT**

DATE 7-24-07

DWG. NO. **AI-1806**