

Model PAB Surface Mount 4, 6, and 8 Foot Athletic Bench with Aluminum Seat



Model PAB/CB-6AU Surface Mount Athletic Bench
with Black Powder Coated Frames, 6 Ft. long
with Blue Powder Coated Aluminum seat.

- **Extra heavy design to be stronger and more stable with a simple, clean style.**
- **Sturdy, formed and welded steel frame construction**
- **Frames are Hot-Dip Galvanized after fabrication for superior corrosion resistance**
- **Structurally reinforced extruded Aluminum Seats with clear anodized finish**
- **Quality construction throughout**

SPECIFICATIONS:

- **Model PAB** end frames shall be one-piece, welded construction with seat bracket of 2" x 2" x 3/16" A-36 structural grade steel angle and a 2.375" (2-3/8") O.D. post and foot to meet 2" nominal steel pipe size specifications. Frame foot shall be formed with flattened and rounded ends. A 9/16" hole shall be provided in each end of foot for optional surface mounting with concrete anchors (anchors not included).
- **Model PAB/G-4AL** shall be 4 ft. long (nom.) with two frames.
- **Model PAB/G-6AL** shall be 6 ft. long (nom.) with two frames and diagonal braces.
- **Model PAB/G-8AL** shall be 8 ft. long (nom.) with two frames and diagonal braces.
- **Standard:** All steel frame components shall be hot-dip galvanized after fabrication to ASTM-A123 to maintain an average zinc coating of 2.0 oz. per sq. ft. of surface area (indicated by "/G" in model no.).
- All galvanized fasteners shall be provided for assembly.
- Aluminum shall be extruded 6063-T6 aluminum alloy in planks with dimensions equivalent to that of 2" x 10" nominal sized lumber. The plank design shall be 1-3/4" x 9-5/8" with four structural reinforcement ribs for greater rigidity. Aluminum planks shall be provided with a clear anodized finish as per anodizing specification 204 R1. Aluminum clips to fasten planks to frames are included.
- Channel end caps shall be of extruded 6063-T6 aluminum alloy provided with a clear anodized finish as per anodizing specification 204 R1. End caps shall be press fitted over ends of aluminum planks and shall be mechanically fastened in place at the factory.
- Aluminum planks shall be provided with galvanized carriage bolts, nuts, and precision fitted aluminum brackets to fasten planks to bench frames.
- **Optional:** Color choices of powder coated steel frame components. For optional colors choices see Specification Bulletin # SPC-CO-001.
- **Optional:** Color choices of powder coated aluminum planks and end caps. For optional colors choices see Specification Bulletin # SPC-CO-001.

AVAILABLE OPTIONS

- 4, 6', or 8' models
- Powder Coat Finish in choice of colors for Steel Frame components
- Powder Coat Finish in choice of colors for Aluminum seat

RJThomas Mfg. Co., Inc.

PO Box 946 • Cherokee, IA 51012-0946 • PH: 712-225-5115 • 800-762-5002 • FAX: 712-225-5796
E-mail: pilotrock@rjthomas.com • Web Site: <http://www.pilotrock.com>

© 2008 RJThomas Mfg. Co., Inc. PILOT ROCK® Park Products is a registered trademark of RJThomas Mfg. Co., Inc.

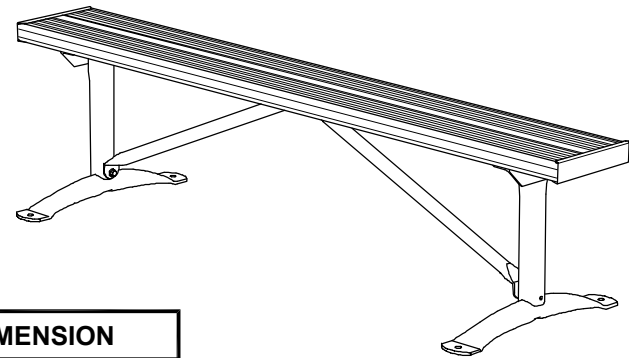
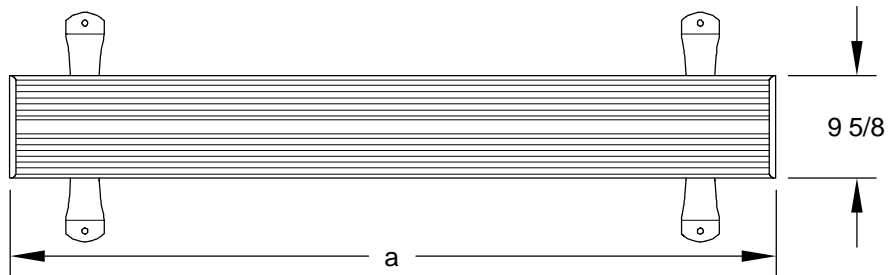

MODEL NUMBER	DIMENSION	
	a	b
PAB-4	48	36
PAB-6	72	57-3/4
PAB-8	96	74 3/4

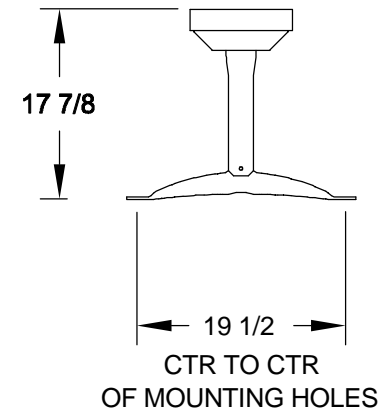
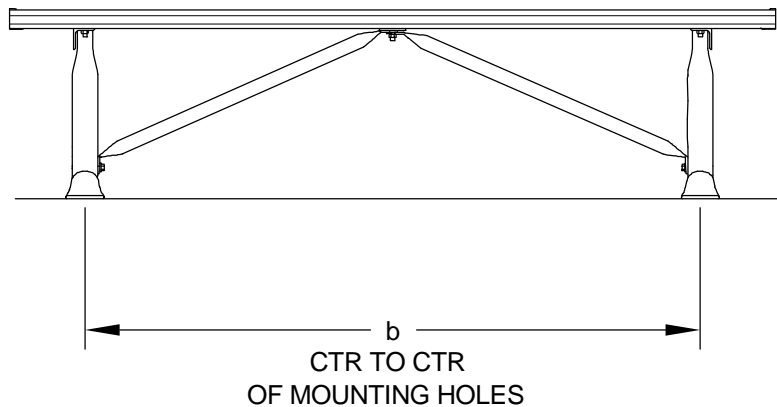

ALL DIMENSIONS IN INCHES

R. J. **THOMAS MFG. Co., INC.**
P.O. Box 946 • Cherokee, IA 51012

DRAWN BY
WWM

TITLE MODEL PAB HEAVY DUTY 4, 6, AND 8 FOOT PORTABLE/SURFACE MOUNT
ATHLETIC BENCH WITH 2" X 10" ALUMINUM PLANKS

DATE 3-29-08

DWG. NO. **AI-1837**