

Model PAB Surface Mount 4, 6, and 8 Foot Athletic Bench with Lumber Seat



Model PAB/G-6TP Surface Mount Athletic Bench
with Hot Dip Galvanized Frames, 6 Ft. long
with 2" x 10" Treated Southern Yellow Pine Lumber seat.

- **Extra heavy design to be stronger and more stable with a simple, clean style.**
- **Sturdy, formed and welded steel frame construction**
- **Frames are Hot-Dip Galvanized after fabrication for superior corrosion resistance**
- **Precision drilled lumber**
- **Quality construction throughout**

SPECIFICATIONS:

- **Model PAB** end frames shall be one-piece, welded construction with seat bracket of 2" x 2" x 3/16" A-36 structural grade steel angle and a 2.375" (2-3/8") O.D. post and foot to meet 2" nominal steel pipe size specifications. Frame foot shall be formed with flattened and rounded ends. A 9/16" hole shall be provided in each end of foot for optional surface mounting with concrete anchors (anchors not included).
- **Model PAB/G-4TP** shall be 4 ft. long (nom.) with two frames.
- **Model PAB/G-6TP** shall be 6 ft. long (nom.) with two frames and diagonal braces.
- **Model PAB/G-8TP** shall be 8 ft. long (nom.) with two frames and diagonal braces.
- **Standard:** All steel frame components shall be hot-dip galvanized after fabrication to ASTM-A123 to maintain an average zinc coating of 2.0 oz. per sq. ft. of surface area (indicated by "/G" in model no.).
- All galvanized fasteners shall be provided for assembly.
- **Standard:** Seat shall be a 2" x 10" (nom.) Treated #1 Southern Yellow Pine plank, pressure treated and kiln dried after treatment (KDAT) to preserve wood against decay (indicated by "TP" at end of the model no.).
- **Optional:** Color choices of powder coated steel frame components. For optional colors choices see Specification Bulletin # SPC-CO-001.
- **Optional:** Seat shall be Untreated #1 Southern Yellow Pine is readily available (To specify, change "TP" in model no. to "UP", e.g. PAB/G-6UP). (Cedar, Fir, and Redwood are available when in stock – please inquire.)

AVAILABLE OPTIONS

- 4', 6', or 8' models
Untreated #1 Southern Yellow Pine, Cedar, Fir, or
Redwood lumber

RJThomas Mfg. Co., Inc.

PO Box 946 • Cherokee, IA 51012-0946 • PH: 712-225-5115 • 800-762-5002 • FAX: 712-225-5796
E-mail: pilotrock@rjthomas.com • Web Site: <http://www.pilotrock.com>

© 2008 RJThomas Mfg. Co., Inc. PILOT ROCK® Park Products is a registered trademark of RJThomas Mfg. Co., Inc.

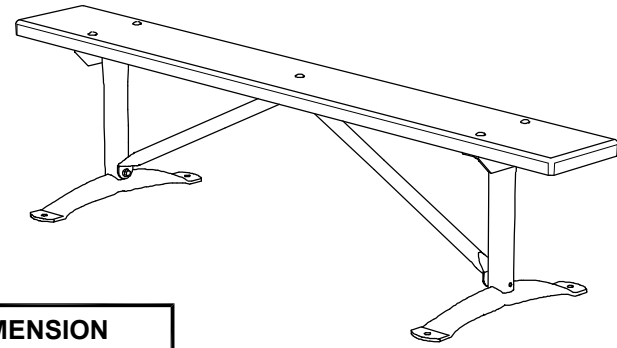
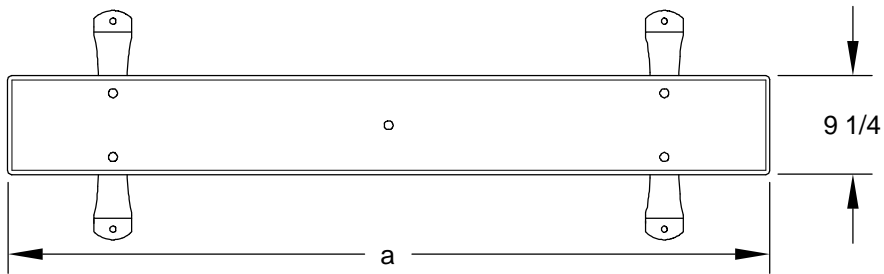

MODEL NUMBER	DIMENSION	
	a	b
PAB-4	47 1/2	36
PAB-6	71 1/2	51-3/4
PAB-8	95 1/2	70

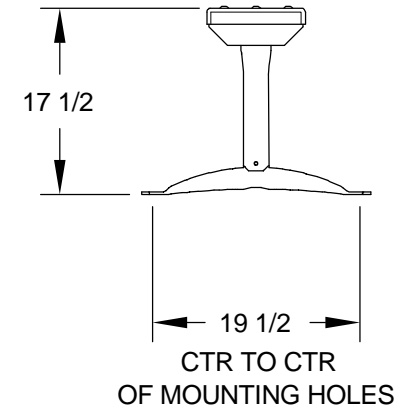
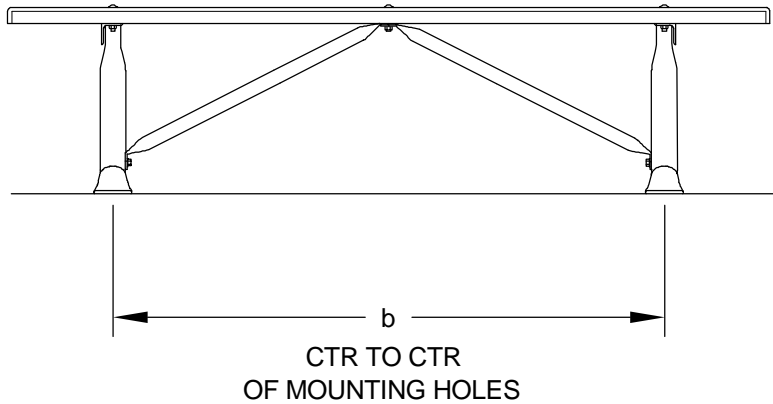

ALL DIMENSIONS IN INCHES

R. J. **THOMAS MFG. Co., INC.**
P.O. Box 946 • Cherokee, IA 51012

DRAWN BY
WWM

TITLE MODEL PAB HEAVY DUTY 4, 6, AND 8 FOOT PORTABLE/SURFACE MOUNT
ATHLETIC BENCH WITH 2" X 10" LUMBER SEAT

DATE 4-08-08

DWG. NO. AI-1840