



Model PAB/CR-6HA10 Embedded Mount Athletic Bench
with Red Powder Coated Frames, 6 Ft. long
with Gray Plastisol Coated H-type Perforated Steel seat.

- **Extra heavy design to be stronger and more stable with a simple, clean style.**
- **Sturdy, formed and welded steel frame construction**
- **Frames are Hot-Dip Galvanized after fabrication for superior corrosion resistance**
- **Plastisol Coating heat fused to Perforated Steel Top for durability**
- **Quality construction throughout**

SPECIFICATIONS:

- **Model SAB** end frames shall be one-piece, welded construction with seat bracket of 2" x 2" x 3/16" A-36 structural grade steel angle and a 2.375" (2-3/8") O.D. post to meet 2" nominal steel pipe size specifications. Both legs shall be embedded in concrete footings.
- **Model SAB/G-4HW10** shall be 4 ft. long (nom.) with two frames.
- **Model SAB/G-6HW10** shall be 6 ft. long (nom.) with two frames.
- **Model SAB/G-8HW10** shall be 8 ft. long (nom.) with two frames.
- **Standard:** All steel frame components shall be hot-dip galvanized after fabrication to ASTM-A123 to maintain an average zinc coating of 2.0 oz. per sq. ft. of surface area (indicated by "/G" in model no.).
- All galvanized fasteners shall be provided for assembly.
- **H-Type** seat shall be one-piece welded construction, fabricated from 14 ga. perforated steel surface with 10 ga. x 2-1/2" roll-formed vertical edges on all sides and reinforced by a 10 ga. die-formed angle substructure. Substructure shall include all mounting holes for easy assembly.
- **Standard:** All steel surfaces of the seat shall be covered with a coating of Brown vinyl Plastisol (indicated by "HW" in model no.) formulated with high impact additives, UV inhibitors, and an anti-microbial to resist mold and mildew. Plastisol coating shall be permanently heat-fused to the steel to an average thickness of 125 mils (1/8") for an overall average thickness, including top and bottom coatings, of 250 mils (1/4").
- **Standard:** Seat shall be 10" wide (nom.), indicated by "10" at end of model number, e.g. SAB/G-4HW10.
- **Optional:** Seat shall be 12" wide (nom.), indicated by "12" at end of model number, e.g. SAB/G-4HW12.
- **Optional:** Color choices of powder coated steel frame components. For optional colors choices see Specification Bulletin # SPC-CO-001.
- **Optional:** Color choices of Plastisol coated components. For optional colors choices see Specification Bulletin # SPC-CO-001.
- **Optional:** Custom lettering available on 12" wide seat. (Please call for details.)

AVAILABLE OPTIONS

- 4', 6', or 8' models
- Powder Coat Finish in choice of colors for Steel Frame components
- Choice of colors of Plastisol Coating
- Custom Lettering available (call for details)

RJThomas Mfg. Co., Inc.

PO Box 946 • Cherokee, IA 51012-0946 • PH: 712-225-5115 • 800-762-5002 • FAX: 712-225-5796
E-mail: pilotrock@rjthomas.com • Web Site: <http://www.pilotrock.com>

© 2008 RJThomas Mfg. Co., Inc. PILOT ROCK® Park Products is a registered trademark of RJThomas Mfg. Co., Inc.

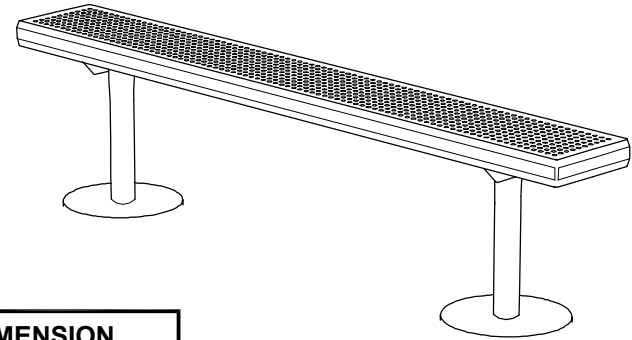
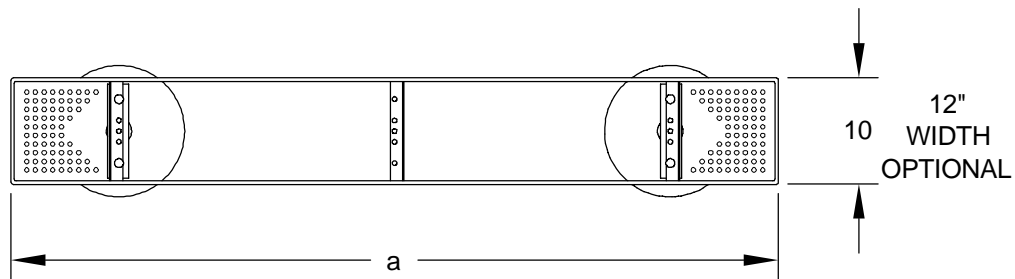

MODEL NUMBER	DIMENSION	
	a	b
SAB-4	48	36
SAB-6	72	51 3/4
SAB-8	96	70

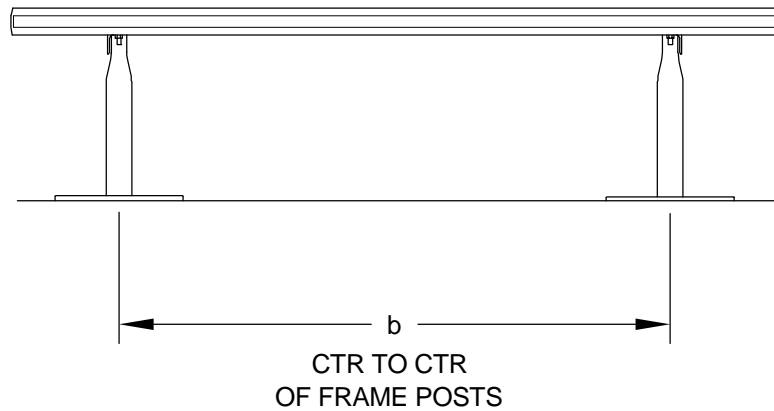

NOTE:
LOCAL SOIL
CONDITIONS
MAY REQUIRE
A LARGER
FOOTING
(CHECK LOCAL
CODES)

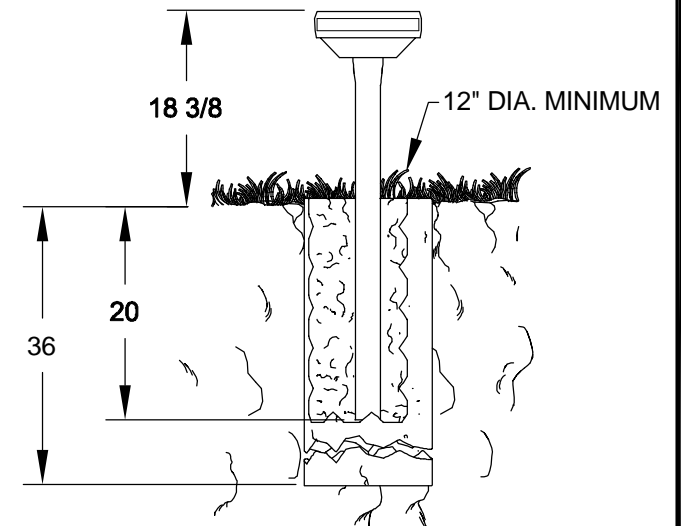

ALL DIMENSIONS IN INCHES

R. J. **THOMAS MFG. Co., INC.**
P.O. Box 946 • Cherokee, IA 51012

DRAWN BY
WWM

TITLE MODEL SAB HEAVY DUTY 4, 6, AND 8 FOOT EMBEDDED MOUNT ATHLETIC BENCH
WITH PLASTISOL COATED H-TYPE PERFORATED STEEL SEAT

DATE 4-09-08

DWG. NO. AI-1842