



*Model BR-12/DS Double sided Safety Bike Rack, 8 ft. long with Hot Dip Galvanized finish. Holds twelve bikes.*

- **Constructed of 1/2" dia. steel bar and die-formed angle**
- **Supports bike by front or rear wheel**
- **Single sided model can hold 6 bikes, double sided models can hold 6 or 12 bikes**
- **Racks will hold all types of bikes and work with most bike security locks**
- **Frames are hot-dip galvanized after fabrication for superior corrosion resistance**

---

**SPECIFICATIONS:**

---

- **Model BR-6/DS** shall be 4' long and mount 6 bikes using both sides.
- **Model BR-6/SS** shall be 8' long and mount 6 bikes using one side only.
- **Model BR-12/DS** shall be 8' long and mount 12 bikes using both sides.
- Bike rack stalls shall be constructed of two 1/2" dia. steel bars formed into curved arches and welded to 3/16" x 1" x 4" A-36 steel flat bar brackets at each end, which shall facilitate the fastening of stalls to base angles. A tire stop of 1/2" dia. steel bar shall be welded between the steel arches. Stalls shall have 2-1/4" spacing for bike tires. Stalls shall be hot-dip galvanized after fabrication.
- Formed galvanized steel base angles shall be 1/8" x nominal 1-1/4" x 1-1/4" and shall provide holes for installation of stalls. Stalls shall be spaced 8" apart on double sided models (every other stall is used on each side for 16" center to center between bikes). Stalls shall be spaced 16" apart on single sided models. Galvanized steel anchor brackets shall be welded to the base angle to provide for concrete installation.
- Galvanized carriage bolts and nuts shall be provided to fasten bike rack stalls to base angles. Assembled Safety Bicycle Rack shall be made theft-resistant by installation of nuts inside base angles and thus, inaccessible when entire unit is ground or concrete anchored.
- **Optional:** Anchor Kit BR-4HSA (set of four 3/8" x 1-7/8" bolt sleeve anchors) shall be provided to secure unit to concrete.

---

**AVAILABLE OPTIONS**

---

Single or double sided  
Anchor kits

**RJThomas Mfg. Co., Inc.**

PO Box 946 • Cherokee, IA 51012-0946 • PH: 712-225-5115 • 800-762-5002 • FAX: 712-225-5796  
E-mail: pilotrock@rjthomas.com • Web Site: <http://www.pilotrock.com>

© 2008 RJThomas Mfg. Co., Inc. PILOT ROCK® Park Products is a registered trademark of RJThomas Mfg. Co., Inc.

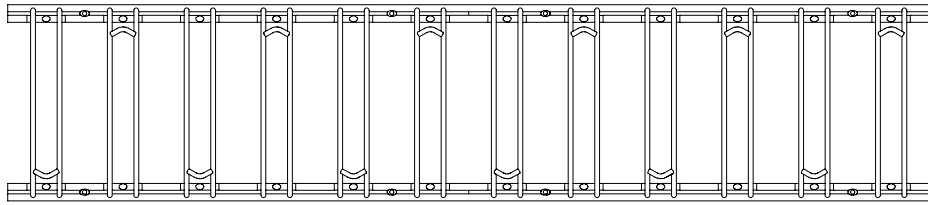

DOUBLE SIDED BR-12/DS

NOTE: WHEEL ENTRY IS ALTERNATED FROM SIDE TO SIDE ON DOUBLE SIDED MODELS

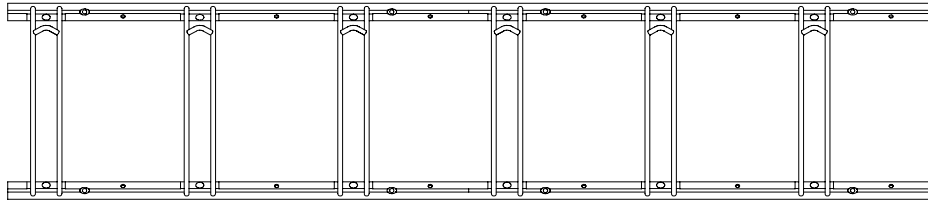

SINGLE SIDED BR-6/SS

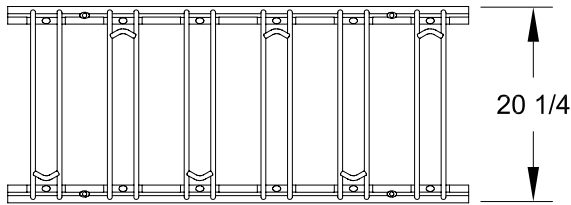

DOUBLE SIDED BR-6/DS

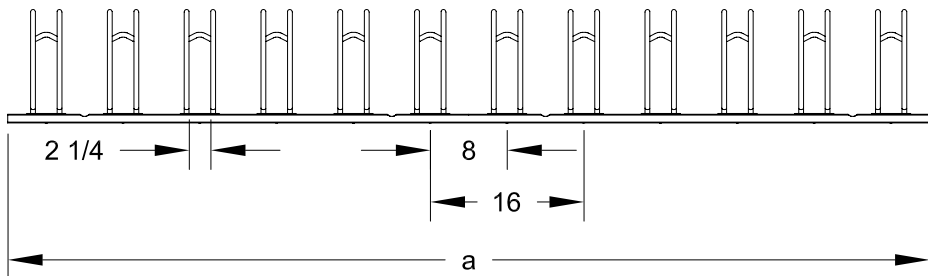

ALL DIMENSIONS IN INCHES

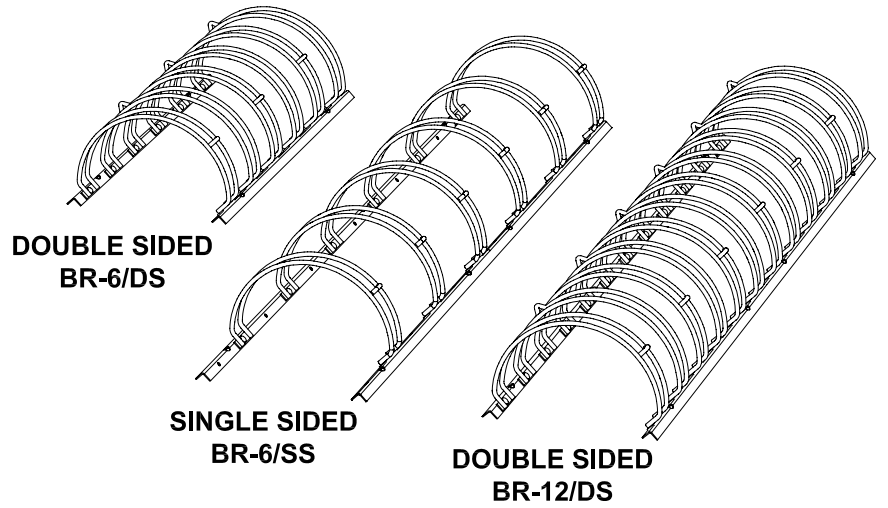

DOUBLE SIDED BR-6/DS

SINGLE SIDED BR-6/SS

DOUBLE SIDED BR-12/DS

MODEL NUMBER	DIMENSION	SIDES OPEN	NUMBER OF BIKES
	a		
BR-6/SS	96	1	6
BR-6/DS	48	2	6
BR-12/DS	96	2	12

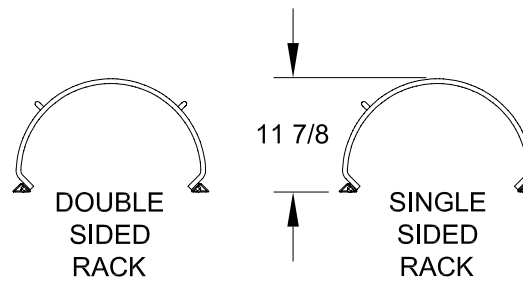

R. J. **THOMAS MFG. Co., INC.**  
P.O. Box 946 • Cherokee, IA 51012

DRAWN BY  
**WWM**

TITLE BR SERIES SINGLE SIDED AND DOUBLE SIDED SAFETY BIKE RACK

DATE 6-26-07

DWG. NO. AI-1801