

# Model ORP Surface Mount Omega Bike Rack



*Model ORP/CU Omega Bike Rack holds two bikes.  
Blue Powder Coat finish.*

- **Simple design holds two bike of any size and works with any bike security device**
- **Hot-dip galvanized after fabrication for superior corrosion resistance**

## **SPECIFICATIONS:**

- **Model ORP** bike rack shall be a one-piece welded construction of 1.90" OD 11 ga. wall steel tubing formed into a 36-3/4" dia. ring and two 4-1/2" dia. x 3/16" thick steel base plates for mounting on hard surfaces.
- Overall nominal height shall be 32".
- **Standard:** Entire unit shall be hot-dip galvanized after fabrication to ASTM-A123 to maintain an average zinc coating of 2.0 oz. per sq. ft. of surface area (indicated by "/G" in model no., e.g. ORP/G).
- **Optional:** Entire unit shall have powder coat finish. For color choices see Specification Bulletin # SPC-CO-001.
- **Optional:** Anchor kit **ANC3-6** with six 3/8" dia. x 3" screw anchors. Order separately.

## **AVAILABLE OPTIONS**

**Choice of colors of Powder Coat Finish**  
**Anchor kit**

**RJThomas Mfg. Co., Inc.**

PO Box 946 • Cherokee, IA 51012-0946 • PH: 712-225-5115 • 800-762-5002 • FAX: 712-225-5796  
E-mail: pilotrock@rjthomas.com • Web Site: <http://www.pilotrock.com>

© 2008 RJThomas Mfg. Co., Inc. PILOT ROCK® Park Products is a registered trademark of RJThomas Mfg. Co., Inc.

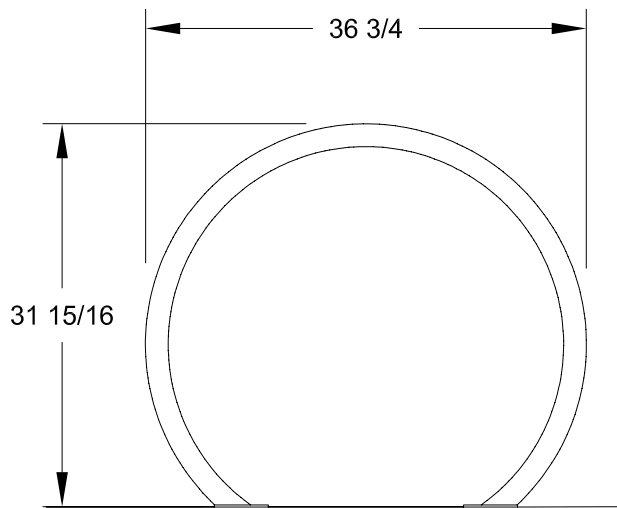
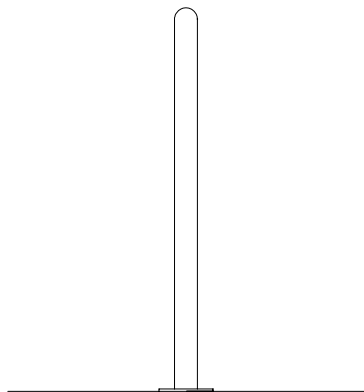
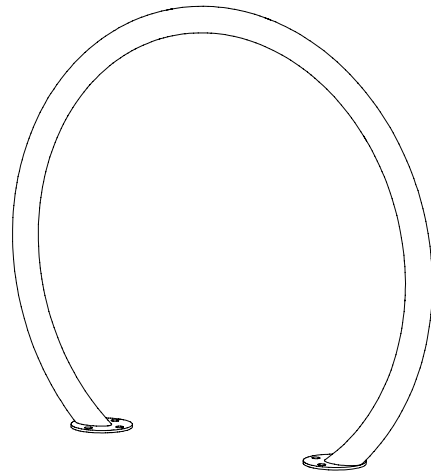
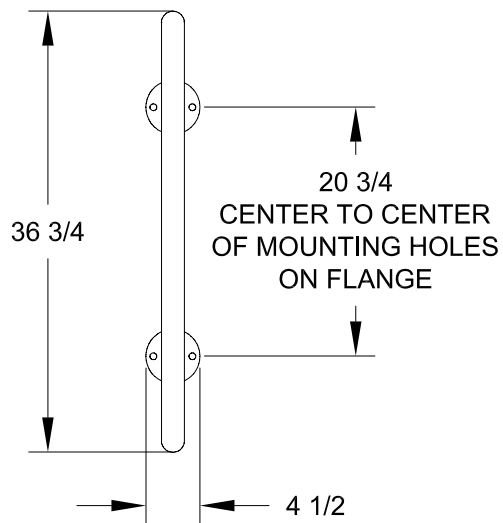

ALL DIMENSIONS IN INCHES

R.J. **THOMAS MFG.**  
**Co., Inc.**  
P.O. Box 946  
Cherokee, IA 51012

TITLE MODEL ORP SURFACE MOUNT OMEGA BIKE RACK

DRAWN BY **WWM**

DATE 7-17-07

DWG. NO. **AI-1803**