

XT Series Extra Heavy Duty Portable Rectangular Tables with Lumber



Model XT/G-6UP 6 Ft. Extra Heavy Duty
Portable Rectangular Table with Hot Dip Galvanized Frame and
Untreated Southern Yellow Pine Planks

- **Constructed specifically for heavy use areas**
- **Nontip, nontrip, walk-through design**
- **All welded end frames are fabricated from 2-3/8" diameter steel pipe**
- **Die-formed center channel and diagonal braces align and strengthen entire table**
- **Frames are hot dip galvanized after fabrication for superior corrosion resistance**
- **Precision drilled, Untreated #1 Southern Yellow Pine Seat and Top Planks**
- **Fast, easy assembly using 3/8" dia. galvanized carriage bolts**
- **Limited lifetime warranty on frames**

SPECIFICATIONS:

- **XT Series** end frames shall be one-piece welded construction, fabricated from 2.375" O.D. (2-3/8" O.D.) steel pipe to meet 2" nominal steel pipe size specifications with 2" x 2" x 3/16" A-36 structural grade steel angle for attaching the seats and tops.
- Table frame design shall incorporate nontip, nontrip, walk-through design features. Bends shall be tightly formed to prevent tipping when weight is on one side.
- Nominal table height shall be 30". Nominal seat height shall be 18". Length shall be per model number, e.g. XT/G-8UP for 8 ft.
- Frames shall be supported by diagonal braces of 1-5/16" O.D. steel pipe that shall connect to a die-formed steel channel designed to align and provide attachment to the table top.
- All 3/8" dia. galvanized carriage bolts and nuts shall be provided to fasten frames and center channel to lumber.
- **Standard:** Frames, diagonal braces, and center channel shall be hot-dip galvanized after fabrication to ASTM-A123 to maintain an average zinc coating of 2.0 oz. per sq. ft. of surface area (indicated by "/G" in model no.).
- **Standard:** Lumber shall be Untreated #1 grade Southern Yellow Pine (indicated by "UP" in model no.) 2" x 10" nominal sized planks, kiln dried to reduce moisture content. All lumber shall be precision drilled to facilitate assembly and shall have all exposed edges removed to a 3/8" radius.
- **Optional:** Color choices of powder coated steel frame components. For optional colors choices see Specification Bulletin # SPC-CO-001.
- **Optional:** Treated #1 Southern Yellow Pine is readily available and shall be pressure treated and kiln dried after treatment (KDAT) to preserve wood against decay. To specify, change "UP" in model no. to "TP", e.g. XT/G-6TP. (Cedar, Fir, and Redwood are available when in stock – please inquire.)
- **Optional:** Table shall be provided with (2) backrest attachments to bolt to the table frame, consisting of (2) pair of backrest brackets and (2) lumber backrest planks.

AVAILABLE OPTIONS

- 6' or 8' lengths
- Powder Coat Finish in choice of colors for steel frame components
- Pressure treated #1 Southern Yellow Pine lumber (Cedar, Fir, or Redwood lumber when in stock)
- Backrest attachments

RJThomas Mfg. Co., Inc.

PO Box 946 • Cherokee, IA 51012-0946 • PH: 712-225-5115 • 800-762-5002 • FAX: 712-225-5796
E-mail: pilotrock@rjthomas.com • Web Site: <http://www.pilotrock.com>

© 2008 RJThomas Mfg. Co., Inc. PILOT ROCK® Park Products is a registered trademark of RJThomas Mfg. Co., Inc.

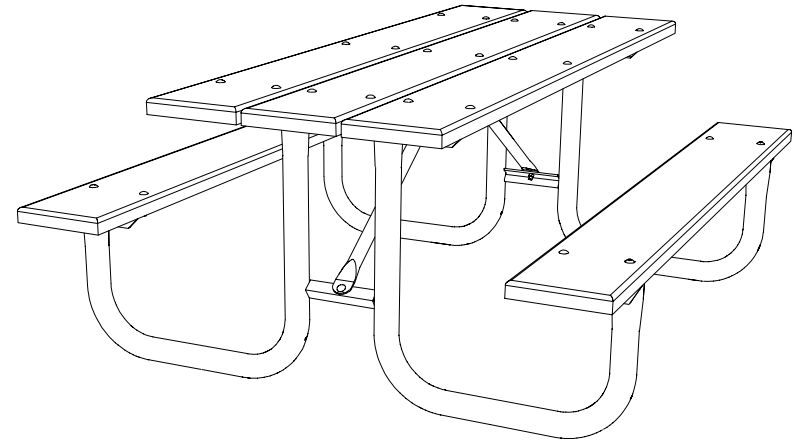
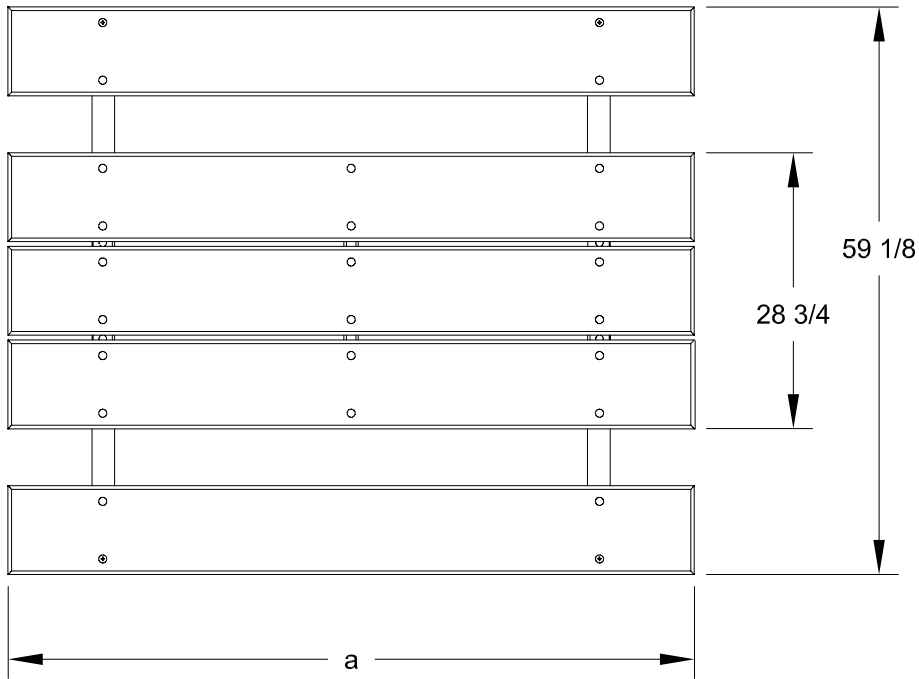

MODEL NUMBER	DIMENSION	
	a	b
XT/G-6	71-1/2	51-3/4
XT/G-8	95-1/2	70

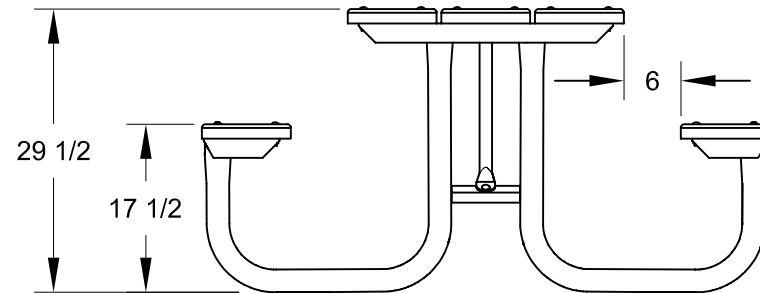
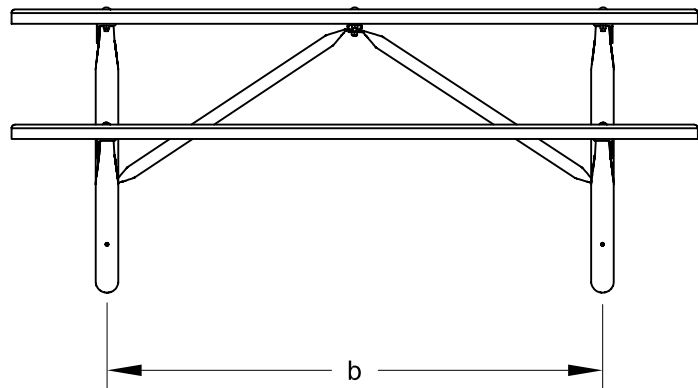

ALL DIMENSIONS IN INCHES

R. J. **THOMAS MFG. CO., INC.**
P.O. Box 946 • Cherokee, IA 51012

DRAWN BY
WWM

TITLE XT SERIES 6 AND 8 FOOT PORTABLE RECTANGULAR TABLES WITH LUMBER TOP
AND SEAT PLANKS

DATE 8-14-02

DWG. NO. **AI-1473**