

UT Series Heavy Duty Portable Rectangular Table with Lumber Top and Seats



*Model UT/G-6UP 6 Ft. Portable Rectangular Table
with Hot Dip Galvanized Frame
and Untreated Southern Yellow Pine Planks*

- **Nontip, nontrip, walk-through design**
- **Strong 1-5/8" diameter all welded, steel pipe end frame construction**
- **Precision drilled, Untreated #1 Southern Yellow Pine seat and top planks**
- **Frames are hot-dip galvanized after fabrication for superior corrosion resistance**
- **Diagonal bracing for strength and rigidity**
- **Die-formed center channel under table top to support and align top planks**
- **Simple bolt together assembly with all 3/8" dia. galvanized carriage bolts included**
- **Limited Lifetime Warranty on frames**

AVAILABLE OPTIONS

- 6' or 8' lengths
- Powder Coat Finish in choice of colors on frame components
- Pressure treated #1 Southern Yellow Pine lumber (Cedar, Fir, or Redwood lumber when in stock)
- Backrest attachments

SPECIFICATIONS:

- **UT Series** end frames shall be one-piece welded construction, fabricated from 1.660" O.D. (1-5/8" O.D.) steel pipe to meet 1-1/4" nominal pipe size specifications with 2" x 2" x 3/16" A-36 structural grade steel angle for attaching the seats and tops.
- Table frame design shall incorporate nontip, nontrip, walk-through design features. Bends shall be tightly formed to prevent tipping when weight is on one side.
- Nominal table height shall be 30". Nominal seat height shall be 18".
- **Model UT/G-6** shall have a nominal 6 ft. length.
- **Model UT/G-8** shall have a nominal 8 ft. length.
- Frames shall be supported by diagonal braces of 1-5/16" O.D. steel pipe that shall connect to a die-formed steel channel designed to align and provide attachment to the table top.
- All fasteners shall be provided for assembly.
- **Standard:** Frames, diagonal braces, and center channel shall be hot-dip galvanized after fabrication to ASTM-A123 to maintain an average zinc coating of 2.0 oz. per sq. ft. of surface area (indicated by "/G" in model no.).
- **Standard:** Lumber shall be Untreated #1 grade Southern Yellow Pine (indicated by "UP" in model no.) 2" x 10" nominal sized planks, kiln dried to reduce moisture content. All lumber shall be precision drilled to facilitate assembly and shall have all exposed edges removed to a 3/8" radius.
- **Optional:** All steel frame components shall have powder coat finish. For color choices see Specification Bulletin #SPC-CO-001.
- **Optional:** Treated #1 Southern Yellow Pine is readily available and shall be pressure treated and kiln dried after treatment (KDAT) to preserve wood against decay. To specify, change "UP" in model no. to "TP", e.g. UT/G-6TP. (Cedar, Fir, and Redwood are available when in stock – please inquire.)
- **Optional:** Table shall be provided with (2) backrest attachments to bolt to the table frame, consisting of (2) pair of backrest brackets and (2) lumber backrest planks.

RJThomas Mfg. Co., Inc.

PO Box 946 • Cherokee, IA 51012-0946 • PH: 712-225-5115 • 800-762-5002 • FAX: 712-225-5796
E-mail: pilotrock@rjthomas.com • Web Site: <http://www.pilotrock.com>

© 2008 RJThomas Mfg. Co., Inc. PILOT ROCK® Park Products is a registered trademark of RJThomas Mfg. Co., Inc.

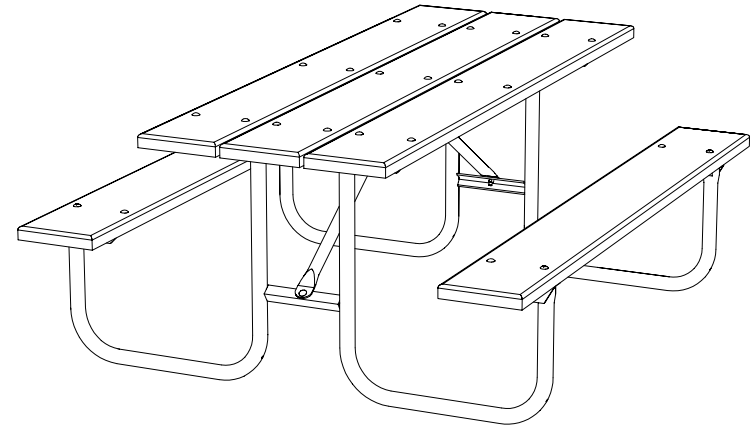
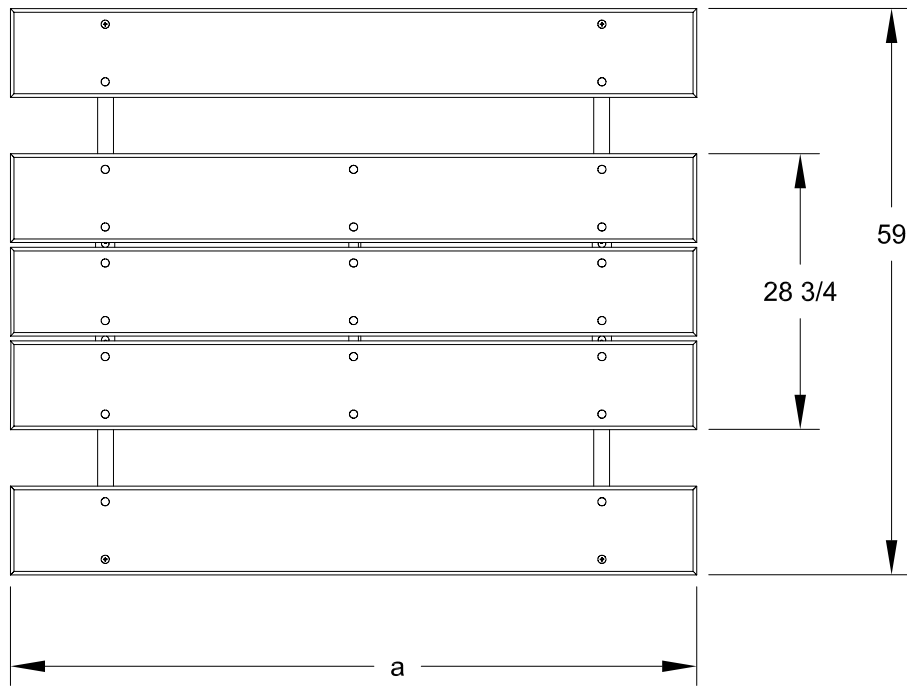

MODEL NUMBER	DIMENSION	
	a	b
UT/G-6	71 1/2	51 3/4
UT/G-8	95 1/2	70

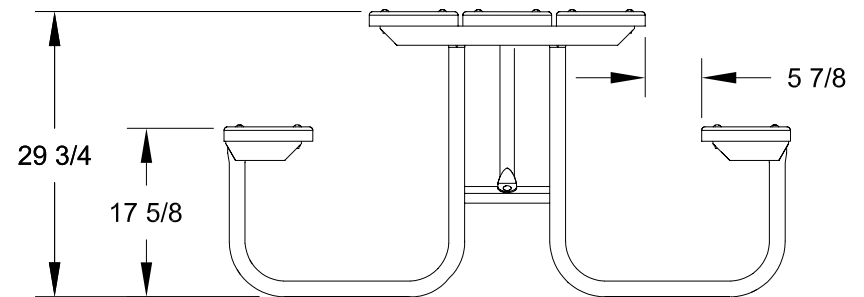
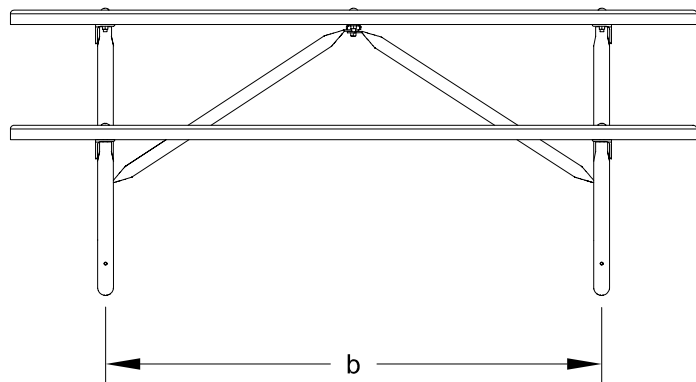

ALL DIMENSIONS IN INCHES

R. J. **THOMAS MFG. CO., INC.**
P.O. Box 946 • Cherokee, IA 51012

DRAWN BY
WWM

TITLE UT SERIES 6 AND 8 FOOT PORTABLE RECTANGULAR TABLES WITH LUMBER
TOP AND SEAT PLANKS

DATE 3-24-03

DWG. NO. **AI-1489**