



*Model XT/G-10VW 10 Ft. Extra Heavy Duty Portable Rectangular
Table with Hot Dip Galvanized Frames and
Brown Plastisol Coated V-Type Expanded Steel Top and Seats*

- **Constructed specifically for heavy use areas**
- **Nontip, nontrip walk-through design**
- **All welded end frames are fabricated from 2-3/8" diameter steel pipe**
- **Diagonal braces align and strengthen entire table**
- **Frames are hot dip galvanized after fabrication for superior corrosion resistance**
- **Plastisol Coating heat fused to Expanded Steel Seats and Top**
- **Vinyl Plastisol formulated with U.V. stabilizers for ultraviolet protection**
- **Limited lifetime warranty on frames**

AVAILABLE OPTIONS

Choice of colors of Powder Coated finish for steel frame components

Choice of colors of Plastisol Coated Expanded Steel

SPECIFICATIONS:

- **XT Series** end frames shall be one-piece welded construction, fabricated from 2.375" (2-3/8") O.D. steel pipe to meet 2" nominal steel pipe size specifications with 2" x 2" x 3/16" A-36 structural grade steel angle for attaching the seats and tops.
- Table frame design shall incorporate nontip, nontrip, walk-through design features. Bends shall be tightly formed to prevent tipping when weight is on one side.
- **Model XT/G-10VW** shall be a nominal 10 ft. long with three frames.
- Nominal table height shall be 31". Nominal seat height shall be 19".
- Frames shall be supported by diagonal braces of 1-5/16" O.D. x 14 ga. wall steel pipe that shall connect to the underside of the table top.
- **Standard:** All frame components shall be hot-dip galvanized after fabrication to ASTM-A123 to maintain an average zinc coating of 2.0 oz. per sq. ft. of surface area (indicated by "/G" in model no.), e.g. XT/G-10VW.
- All galvanized fasteners shall be provided for assembly.
- **V-Type** table top and seats shall each be a one-piece welded construction, fabricated from a 3/4-#9 expanded steel surface with 10 ga. x 2-1/2" roll-formed vertical edges on all sides and reinforced by a 10 ga. die-formed angle substructure. Substructure shall include all mounting holes for easy assembly of table.
- **Standard:** All steel surfaces of the top and seats shall be covered with a coating of Brown vinyl Plastisol (indicated by "VW in model no., e.g. XT/G-10VW) formulated with high impact additives, UV inhibitors, and an anti-microbial to resist mold and mildew. Plastisol coating shall be permanently heat-fused to the steel to an average thickness of 125 mils (1/8") for an overall average thickness, including top and bottom coatings, of 250 mils (1/4").
- **Optional:** Color choices of powder coated steel frame components. For optional colors choices see Specification Bulletin # SPC-CO-001.
- **Optional:** Color choices of plastisol coated steel components. For optional colors choices see Specification Bulletin # SPC-CO-001.

RJThomas Mfg. Co., Inc.

PO Box 946 • Cherokee, IA 51012-0946 • PH: 712-225-5115 • 800-762-5002 • FAX: 712-225-5796
E-mail: pilotrock@rjthomas.com • Web Site: <http://www.pilotrock.com>

© 2008 RJThomas Mfg. Co., Inc. PILOT ROCK® Park Products is a registered trademark of RJThomas Mfg. Co., Inc.

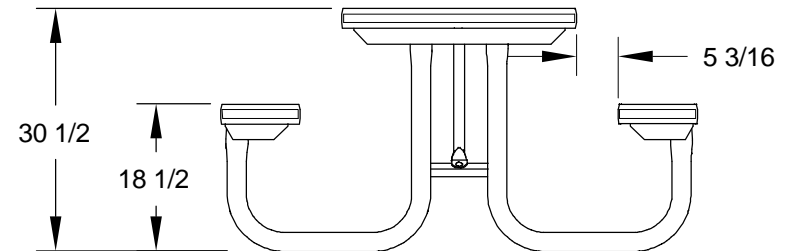
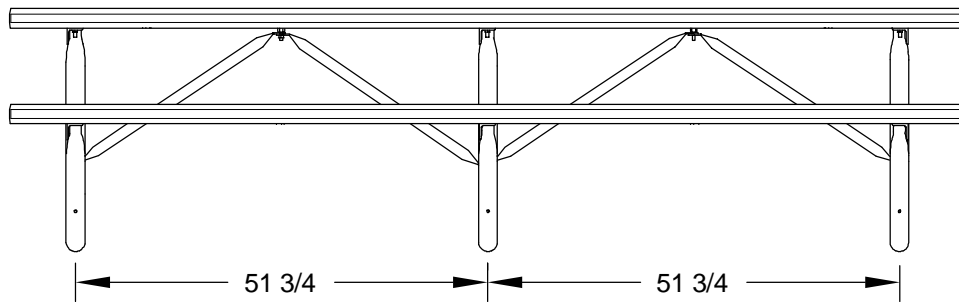
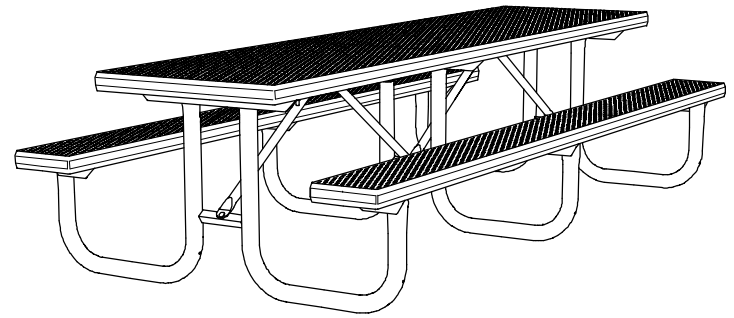
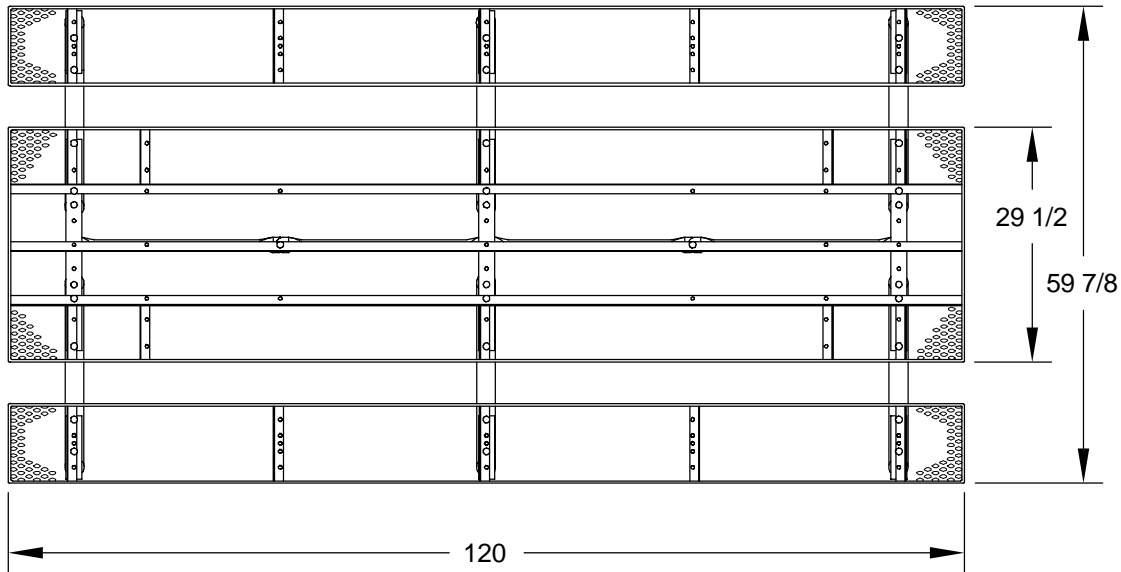

R. J. **THOMAS MFG. Co., INC.**
 P.O. Box 946 • Cherokee, IA 51012

DRAWN BY
WWM

TITLE **XT SERIES EXTRA HEAVY DUTY 10 FOOT PORTABLE RECTANGULAR TABLE WITH PLASTISOL COATED V-TYPE EXPANDED STEEL TOP AND SEATS**

DATE **4-24-08**

DWG. NO. **AI-1626**