

PQT Series 3 and 4 Foot Square Pedestal Table with Aluminum Top and Seats



*Model PQT/G-4AL 5 Plank, 48" Square Top, Embedded Mount Table
with Hot dip Galvanized Frame
and Aluminum Top and Seat Planks*

- **Square design optimizes table top usage and creates a more intimate setting**
- **Square table fits into more compact areas**
- **Permanent embedded mounting**
- **Sturdy 5-3/8" square center pedestal, 3-1/2" diameter round radial seat supports**
- **Frames are hot dip galvanized after fabrication for superior corrosion resistance**
- **Seats and Top are Aluminum with a clear anodized maintenance-free finish**
- **Quality construction throughout**

AVAILABLE OPTIONS

3' or 4' square models

Powder Coat Finish in choice of colors for steel frame components

Powder Coat Finish in choice of colors for aluminum top and seats

Choice of two Umbrella styles with mounting hardware

Surface mount base plate

SPECIFICATIONS:

- **PQT Series** table frame shall incorporate a 5-3/8" square single center pedestal post designed to be embedded in a concrete footing.
- Four seat support frames shall each be a one-piece welded construction of 3-1/2" dia. x 11 ga. wall structural steel tubing, a 2-3/8" dia. 10 ga. wall tube, and 1-3/4" x 1-3/4" x 1/8" A-36 structural steel angles designed to resist lateral torsion and deflection when loaded.
- Frame shall assemble in a theft-proof manner with all fasteners extending into the central post to prevent removal once the table is assembled.
- **Model PQT/G-3** shall have a nominal 3 ft. square top.
- **Model PQT/G-4** shall have a nominal 4 ft. square top.
- Nominal table height shall be 32-3/16". Nominal seat height shall be 20-1/4".
- Top planks shall be supported by a subframe of 1-3/4" x 1-3/4" x 1/8" A-36 structural steel angle, 10 ga. steel channel, and 2-3/8" round tubing.
- All galvanized fasteners shall be provided for assembly.
- **Standard:** All steel frame components shall be hot-dip galvanized after fabrication to ASTM-A123 to maintain an average zinc coating of 2.0 oz. per sq. ft. of surface area (indicated by "/G" in model no.).
- Aluminum shall be extruded 6063-T6 aluminum alloy in planks with dimensions equivalent to that of 2" x 10" nominal sized lumber. The plank design shall be 1-3/4" x 9-5/8" with four structural reinforcement ribs for greater rigidity. Aluminum planks shall be provided with a clear anodized finish as per anodizing specification 204 R1. Aluminum clips to fasten planks to frames are included.
- Channel end caps shall be of extruded 6063-T6 aluminum alloy provided with a clear anodized finish as per anodizing specification 204 R1. End caps shall be press fitted over ends of aluminum planks and mechanically fastened in place at the factory.
- Table tops are assembled into single units at the factory with one-piece end caps across each end.
- **Optional:** All steel frame components shall have powder coat finish. For color choices see Specification Bulletin # SPC-CO-001.
- **Optional:** Aluminum top and seat planks and end caps shall have powder coat finish. For color choices see Specification Bulletin # SPC-CO-001.
- **Optional:** Tables shall be provided with umbrella holes in table tops and cup and collar sets for mounting umbrellas. To specify, add "/U" to the end of the model no., e.g. PQT/G-3AL/U.
- **Optional:** Frame shall be provided with a 3/8" x 15-3/4" x 15-3/4" steel base plate to bolt table to existing concrete pad. To specify add "/P" after the "PQT" in the model no., e.g. PQT/P/G-4AL. (Anchor bolts not included.)

RJThomas Mfg. Co., Inc.

PO Box 946 • Cherokee, IA 51012-0946 • PH: 712-225-5115 • 800-762-5002 • FAX: 712-225-5796
E-mail: pilotrock@rjthomas.com • Web Site: <http://www.pilotrock.com>

© 2008 RJThomas Mfg. Co., Inc. PILOT ROCK® Park Products is a registered trademark of RJThomas Mfg. Co., Inc.

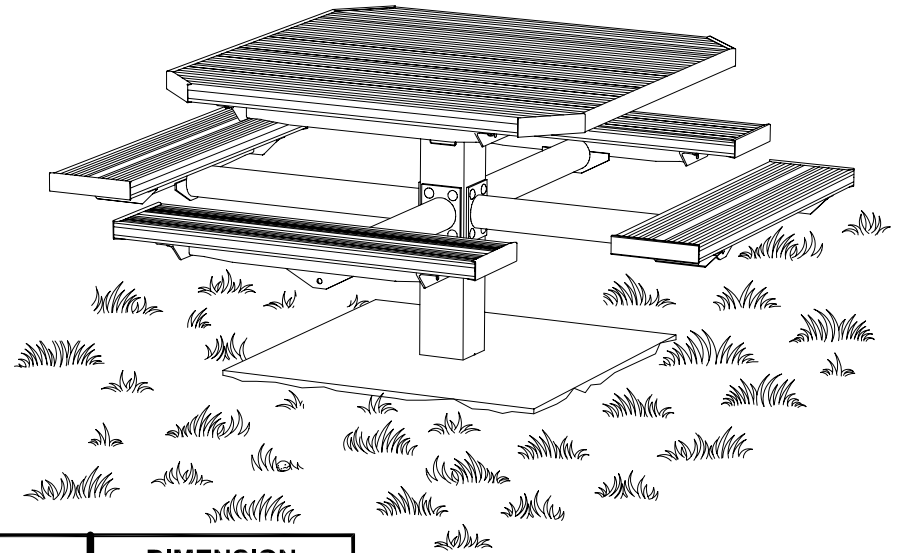
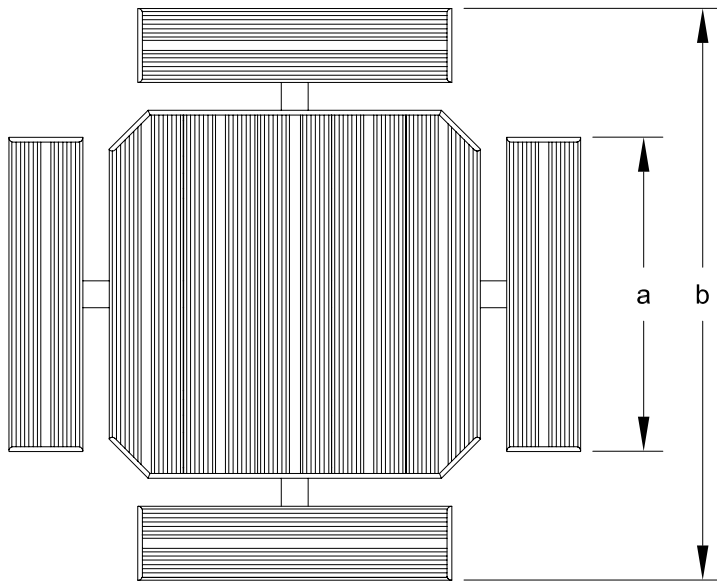

MODEL NUMBER	DIMENSION	
	a	b
PQT-3	33 29/32	68 1/2
PQT-4	40 15/16	74 5/8

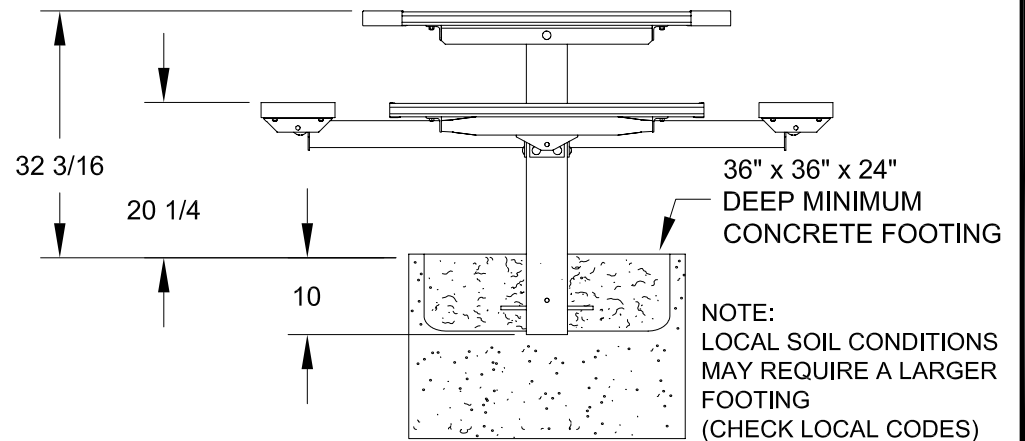
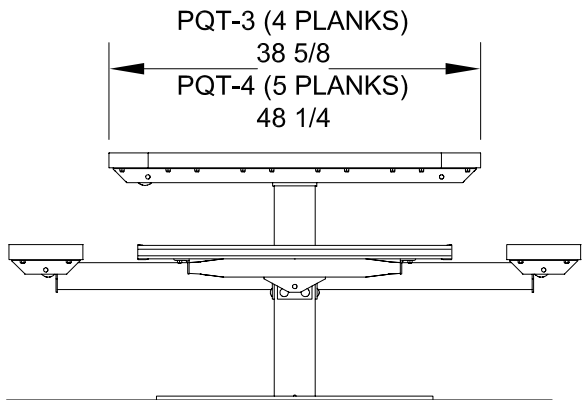

ALL DIMENSIONS IN INCHES

R. J. **THOMAS MFG. CO., INC.**
P.O. Box 946 • Cherokee, IA 51012

DRAWN BY
WWM

TITLE PQT SERIES 3 AND 4 FOOT EMBEDDED MOUNT SQUARE SINGLE PEDESTAL TABLE
WITH ALUMINUM TOP AND SEAT PLANKS

DATE 10-10-05

DWG. NO. **AI-1697**