

PT Series 6 Foot Single Pedestal Rectangular Table with Aluminum Top and Seats

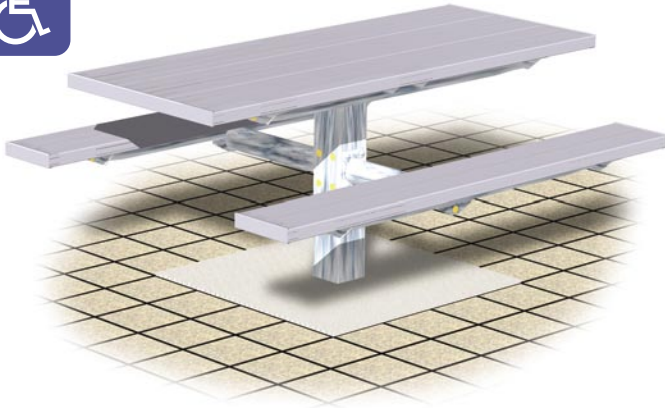

Model PT/G-6AL 6 ft. Rectangular Embedded Mount Table with Hot dip Galvanized Frame and Aluminum Top and Seats

- **Permanent embedded mounting**
- **Sturdy 5-3/8" square center pedestal, 3-1/2" diameter round radial seat supports**
- **Wheelchair accessible design**
- **Frames are hot dip galvanized after fabrication for superior corrosion resistance**
- **Seats and Top are Aluminum with a clear anodized maintenance free finish**
- **Quality construction throughout**

AVAILABLE OPTIONS

- **Powder Coat Finish in choice of colors for steel frame components**
- **Powder Coat Finish in choice of colors for aluminum top and seats**
- **Surface mount base plate**

SPECIFICATIONS:

- **PT Series** table frame shall incorporate a 5-3/8" square single center pedestal post designed to be embedded in a concrete footing.
- Two seat support frames shall each be a one-piece welded construction of 3-1/2" dia. x 11 ga. wall structural steel tubing, a 2-3/8" dia. 10 ga. wall tube, and 1-3/4" x 1-3/4" x 1/8" A-36 structural steel angles designed to resist lateral torsion and deflection when loaded.
- Frame shall assemble in a theft-proof manner with all fasteners extending into the central post to prevent removal once the table is assembled.
- **Model PT/G-6** shall have a nominal 6 ft. length.
- Nominal table height shall be 32". Nominal seat height shall be 20".
- Top planks shall be supported by a subframe of 1-3/4" x 1-3/4" x 1/8" A-36 structural steel angle, 10 ga. steel channel, and 2-3/8" round tubing.
- All galvanized fasteners shall be provided for assembly.
- **Standard:** All steel frame components shall be hot-dip galvanized after fabrication to ASTM-A123 to maintain an average zinc coating of 2.0 oz. per sq. ft. of surface area (indicated by "/G" in model no.).
- Aluminum shall be extruded 6063-T6 aluminum alloy in planks with dimensions equivalent to that of 2" x 10" nominal sized lumber. The plank design shall be 1-3/4" x 9-5/8" with four structural reinforcement ribs for greater rigidity. Aluminum planks shall be provided with a clear anodized finish as per anodizing specification 204 R1. Aluminum clips to fasten planks to frames are included.
- Channel end caps shall be of extruded 6063-T6 aluminum alloy provided with a clear anodized finish as per anodizing specification 204 R1. End caps shall be press fitted over ends of aluminum planks and mechanically fastened in place at the factory.
- Table tops are assembled into single units at the factory with one-piece end caps across each end.
- **Optional:** All steel frame components shall have powder coat finish. For color choices see Specification Bulletin # SPC-CO-001.
- **Optional:** Aluminum top and seat planks and end caps shall have powder coat finish. For color choices see Specification Bulletin # SPC-CO-001.
- **Optional:** Frame shall be provided with a 3/8" x 15-3/4" x 15-3/4" steel base plate to bolt table to existing concrete pad. To specify add "/P" after the "PT" in the model no., e.g. PT/P/G-6AL. (Anchor bolts not included.)

RJThomas Mfg. Co., Inc.

PO Box 946 • Cherokee, IA 51012-0946 • PH: 712-225-5115 • 800-762-5002 • FAX: 712-225-5796
E-mail: pilotrock@rjthomas.com • Web Site: <http://www.pilotrock.com>

© 2008 RJThomas Mfg. Co., Inc. PILOT ROCK® Park Products is a registered trademark of RJThomas Mfg. Co., Inc.

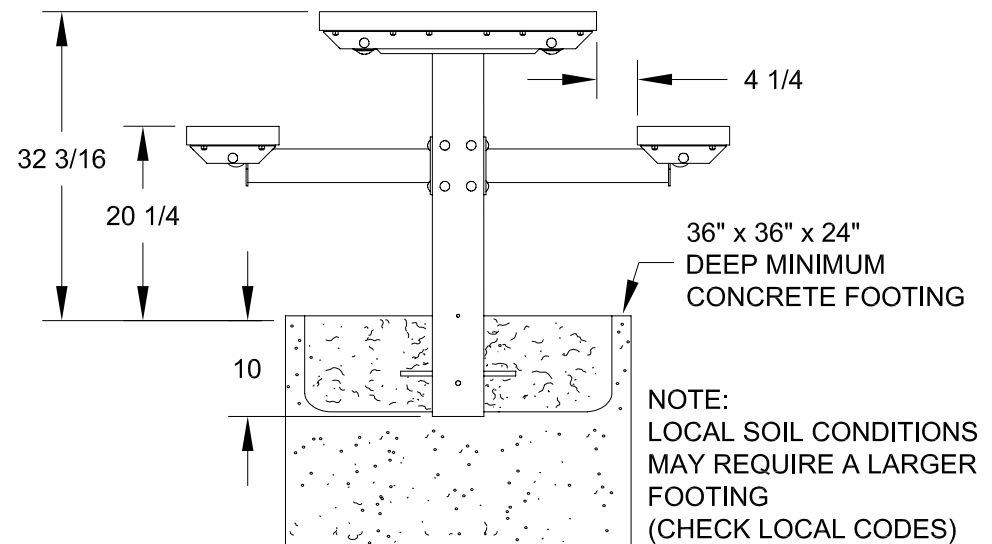
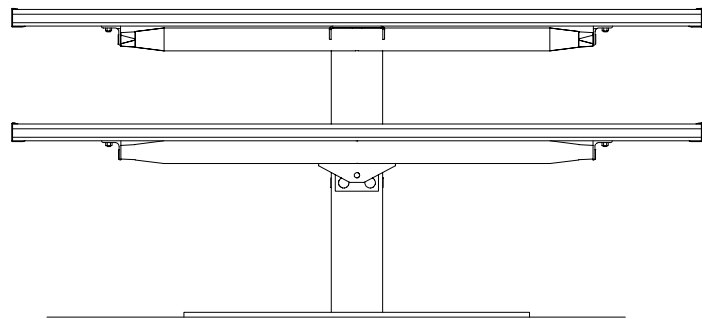
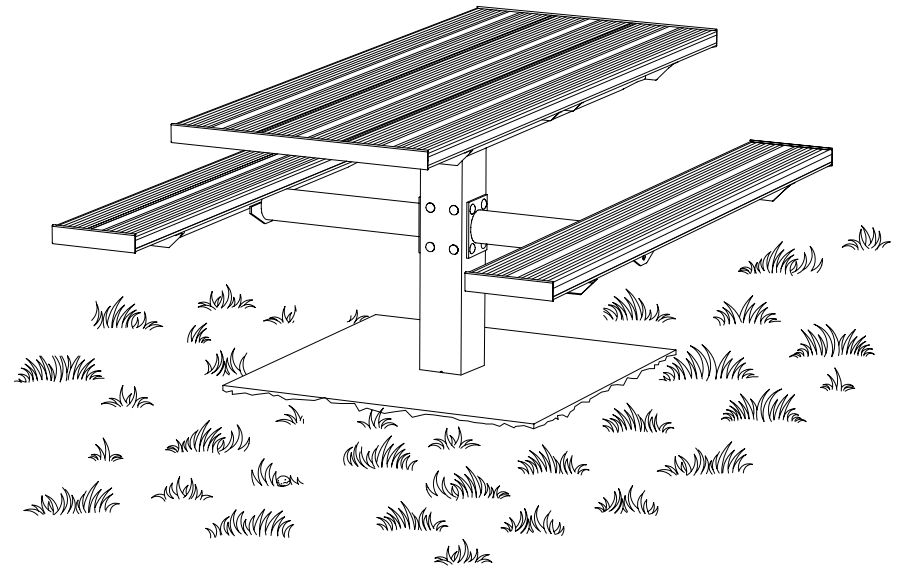
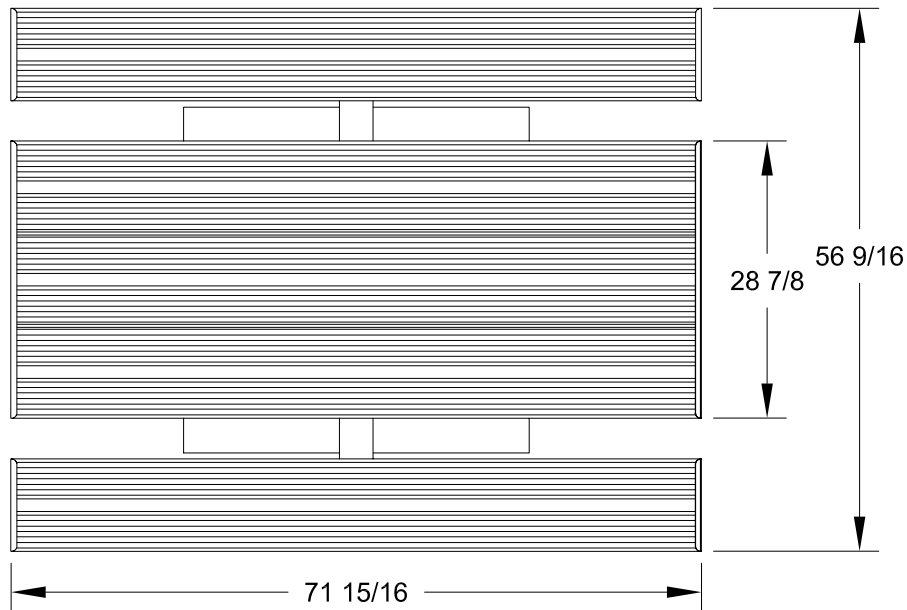

ALL DIMENSIONS IN INCHES

R. J. **THOMAS MFG. CO., INC.**
P.O. Box 946 • Cherokee, IA 51012

DRAWN BY
WWM

TITLE PT SERIES 6 FOOT EMBEDDED MOUNT RECTANGULAR SINGLE PEDESTAL TABLE
WITH ALUMINUM TOP AND SEAT PLANKS

DATE 01-13-05

DWG. NO. **AI-1711**