

RT Series 6 Foot Wheelchair Accessible Recycled Plastic Rectangular Table

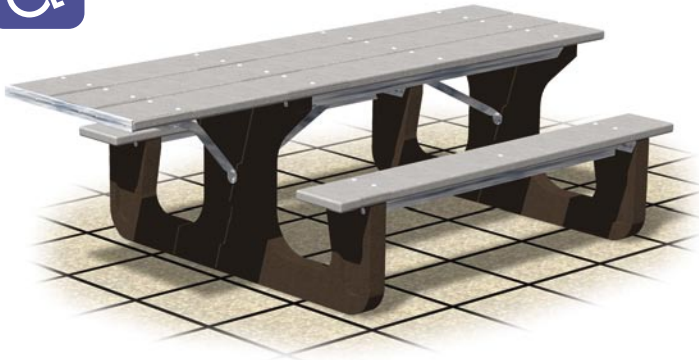

- **Molded 100% Recycled Plastic Legs**
- **100% Recycled Plastic Seat and Top Planks**
- **Solid color throughout plastic and U.V. stabilizer for ultraviolet protection**
- **Pregalvanized steel channel reinforcements under seats and table top**
- **Quality construction throughout**

SPECIFICATIONS:

- **RT Series** table end frames shall be molded of 100% recycled plastic in 3" thick profiles and shall be predrilled to mount seat angles, top angles and diagonal braces. Tables shall provide a nom. seat height of 17-1/2" and nom. table top height of 30".
- Table tops and seats shall be supported by pregalvanized steel subframe channels. Tables shall be supported by diagonal braces of 1-5/16" O.D. galvanized steel pipe that shall connect to a die-formed steel channel designed to align and provide attachment to the table top.
- Table top shall extend 2 ft. beyond seats to provide the ADA recommended wheelchair clearances of: 30" wide, 27" under table (ground to bottom of table top), and 24" total knee and toe clearance (19" + 5") at both ends. A diagonal brace of 1-5/16" O.D., hot-dip galvanized, steel pipe and a die-formed steel channel shall be provided to support extended portions of table top and maintain planks against warping. A pregalvanized steel end cap on extended end of table top shall be included to keep ends of planks aligned.
- **Model RT/W-6C/E** shall have a nominal seat length of 72" and a nominal table top length of 96".
- All 3/8" dia. galvanized carriage bolts and nuts shall be provided to fasten frames, supports, and top and seat planks together.
- **Standard:** End frames shall be made of 3" thick 100% Recycled Plastic with solid Brown color (indicated by "/W" following RT in model no.) formed throughout and a U.V. stabilizer added for ultra-violet protection.
- **Standard:** Tops and seats shall be made of 100% Recycled Plastic molded into 2" x 10" nominal sized planks with solid Cedar colored (indicated by "C" in model no.) formed throughout and a U.V. stabilizer added for ultra-violet protection.
- **Optional:** Color choices of Recycled Plastic components. For optional colors choices see Specification Bulletin #SPC-CO-001.

AVAILABLE OPTIONS

Choice of colors of Recycled Plastic
Custom Lettering and Plaques available (call for details)

RJThomas Mfg. Co., Inc.

PO Box 946 • Cherokee, IA 51012-0946 • PH: 712-225-5115 • 800-762-5002 • FAX: 712-225-5796
E-mail: pilotrock@rjthomas.com • Web Site: <http://www.pilotrock.com>

© 2008 RJThomas Mfg. Co., Inc. PILOT ROCK® Park Products is a registered trademark of RJThomas Mfg. Co., Inc.

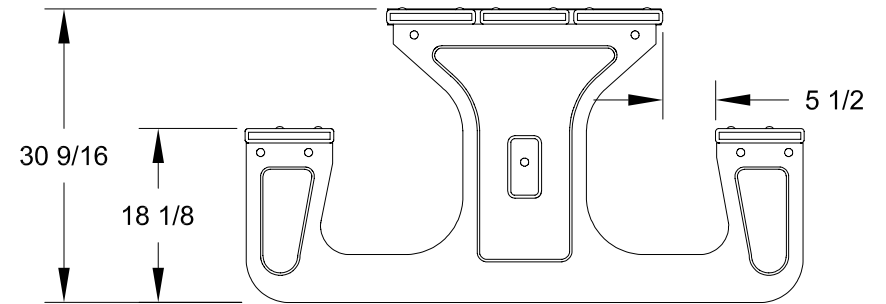
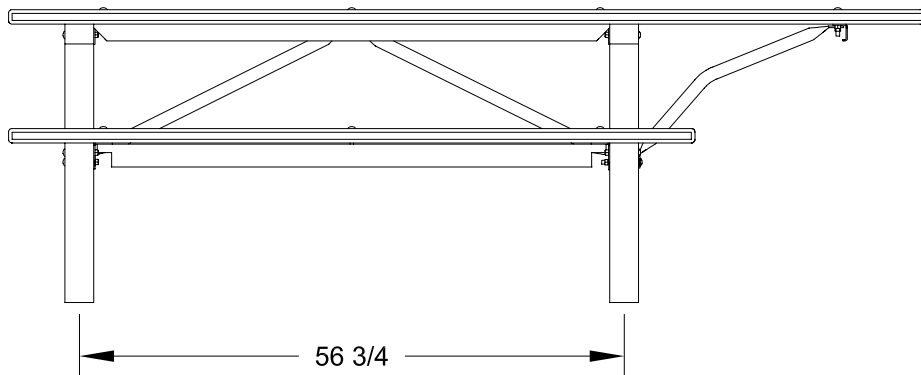
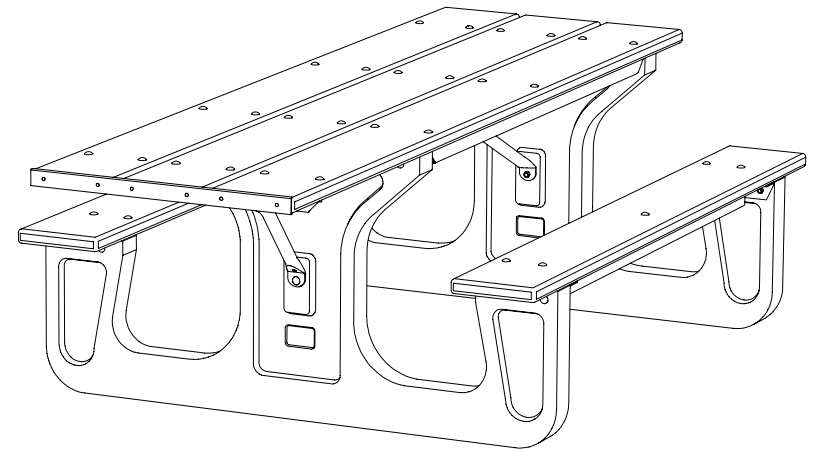
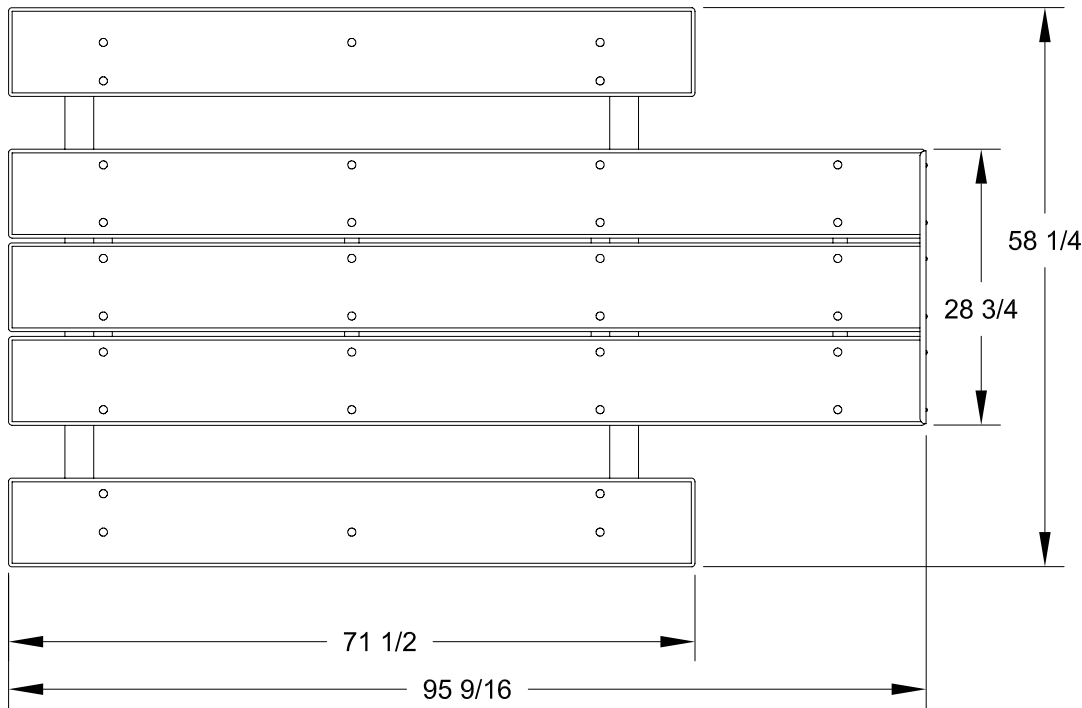

ALL DIMENSIONS IN INCHES

R. J. **THOMAS MFG. CO., INC.**
 P.O. Box 946 • Cherokee, IA 51012

DRAWN BY
WWM

TITLE RT SERIES 6 FOOT WHEELCHAIR ACCESSIBLE RECYCLED PLASTIC RECTANGULAR
 TABLE EXTENDED 2 FOOT ON ONE END

DATE 2-17-06

DWG. NO. **AI-1718**