

# UTK Series 4, 6, and 8 Foot Children's Rectangular Table with Aluminum Top and Seats



*Model UTK/G-6AL 6 ft. Children's Rectangular Table  
with Hot Dip Galvanized frames and Aluminum top and seats*

- **Scaled to fit children up to 12 years of age**
- **Nontip, nontrip, walk-through design**
- **Strong 1-5/8" diameter all welded, steel pipe end frame construction**
- **Frames are hot-dip galvanized after fabrication for superior corrosion resistance**
- **Diagonal bracing for strength and rigidity**
- **Die-formed center channel under table top to support and align top planks**
- **Seats and Top are Aluminum with a clear anodized maintenance free finish**
- **Limited Lifetime Warranty on frames**

## AVAILABLE OPTIONS

**4, 6, or 8 foot lengths**

**Powder Coat Finish in choice of colors for steel frame components**

**Powder Coat Finish in choice of colors for aluminum top and seats**

## SPECIFICATIONS:

- **UTK Series** end frames shall be one-piece welded construction, fabricated from 1.660" O.D. (1-5/8" O.D.) steel pipe to meet 1-1/4" nominal pipe size specifications with 2" x 2" x 3/16" A-36 structural grade steel angle for attaching the seats and tops.
- Table frame design shall incorporate nontip, nontrip, walk-through design features. Bends shall be tightly formed to prevent tipping when weight is on one side.
- Nominal table height shall be 22". Nominal seat height shall be 12".
- **Model UTK/G-4** shall have a 4 ft. nominal length.
- **Model UTK/G-6** shall have a 6 ft. nominal length.
- **Model UTK/G-8** shall have a 8 ft. nominal length.
- Frames shall be supported by diagonal braces of 1-5/16" O.D. steel pipe that shall connect to a die-formed steel channel designed to align and provide attachment to the table top.
- All galvanized fasteners shall be provided for assembly.
- **Standard:** All steel frame components shall be hot-dip galvanized after fabrication to ASTM-A123 to maintain an average zinc coating of 2.0 oz. per sq. ft. of surface area (indicated by "/G" in model no.).
- Aluminum shall be extruded 6063-T6 aluminum alloy in planks with dimensions equivalent to that of 2" x 10" nominal sized lumber. The plank design shall be 1-3/4" x 9-5/8" with four structural reinforcement ribs for greater rigidity. Aluminum planks shall be provided with a clear anodized finish as per anodizing specification 204 R1. Aluminum clips to fasten planks to frames are included.
- Channel end caps shall be of extruded 6063-T6 aluminum alloy provided with a clear anodized finish as per anodizing specification 204 R1. End caps shall be press fitted over ends of aluminum planks and mechanically fastened in place at the factory.
- Table tops are assembled into single units at the factory with one-piece end caps across each end.
- **Optional:** All steel frame components shall have powder coat finish. For color choices see Specification Bulletin # SPC-CO-001.
- **Optional:** Aluminum top and seat planks and end caps shall have powder coat finish. For color choices see Specification Bulletin # SPC-CO-001.

**RJThomas Mfg. Co., Inc.**

PO Box 946 • Cherokee, IA 51012-0946 • PH: 712-225-5115 • 800-762-5002 • FAX: 712-225-5796  
E-mail: pilotrock@rjthomas.com • Web Site: <http://www.pilotrock.com>

© 2008 RJThomas Mfg. Co., Inc. PILOT ROCK® Park Products is a registered trademark of RJThomas Mfg. Co., Inc.

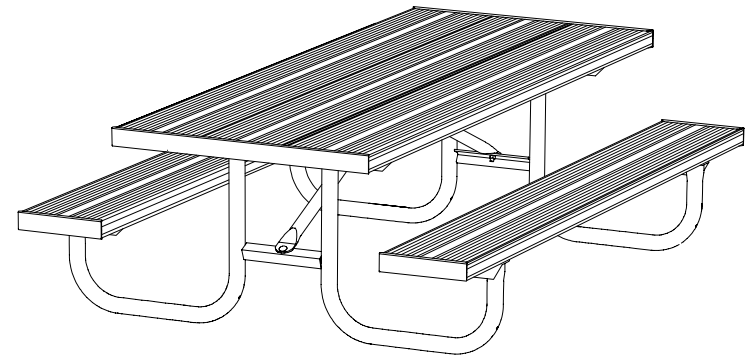
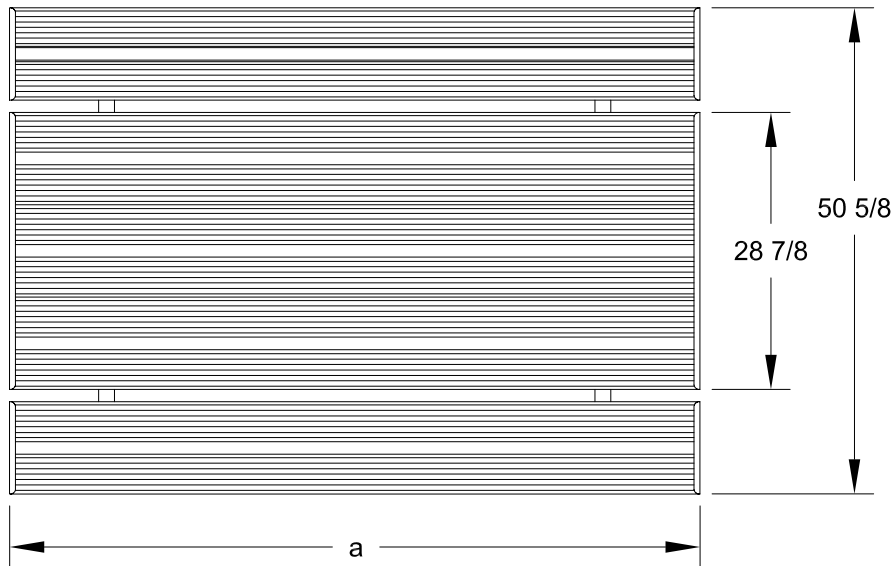

| MODEL NUMBER | DIMENSION |        |
|--------------|-----------|--------|
|              | a         | b      |
| UTK-4        | 48        | 30     |
| UTK-6        | 72        | 51-3/4 |
| UTK-8        | 96        | 70     |

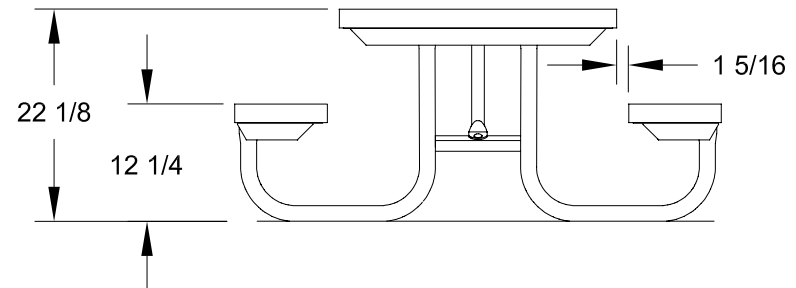
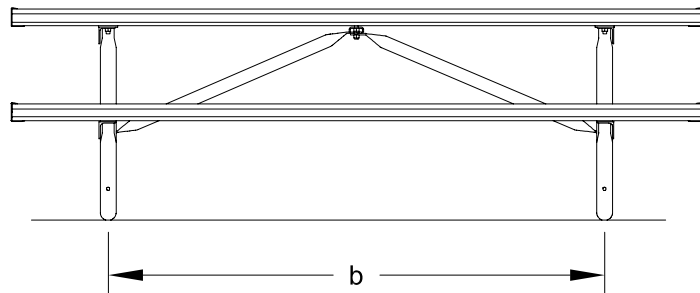

ALL DIMENSIONS IN INCHES

R. J. **THOMAS MFG. Co., Inc.**  
P.O. Box 946 • Cherokee, IA 51012

DRAWN BY  
**WWM**

TITLE UTK SERIES 4, 6, AND 8 FOOT CHILDRENS RECTANGULAR PORTABLE TABLE  
WITH ALUMINUM TOP AND SEAT PLANKS

DATE 1-18-07

DWG. NO. **AI-1749**