

APT Series 6 and 8 foot Double Pedestal Rectangular Table with Recycled Plastic Top and Seat Planks



Model APT/G-6PR 6 ft. embedded mount double pedestal rectangular table with hot dip galvanized frame and red recycled plastic top and seat planks

- **Permanent embedded mounting**
- **Nontrip, walk-through design**
- **Sturdy 3" x 6" rectangular steel tube pedestals**
- **Frames are hot-dip galvanized after fabrication for superior corrosion resistance**
- **100% Recycled Plastic Seat and Top Planks with solid color and U.V. stabilizer for ultraviolet protection**
- **Pregalvanized steel channel reinforcements under seats and table top**
- **Die-formed center channel under table top to support and align top planks**
- **Quality construction throughout**

SPECIFICATIONS:

- **APT Series** Table top and seat end frames shall be one-piece welded construction, fabricated from 3" x 6" x 1/8" wall rectangular structural steel tubing with 2" x 2" x 3/16" A-36 structural grade steel angle for attaching the seats and tops. Exposed ends of rectangular tubing shall be permanently sealed with welded-on steel end caps. Frames are designed to be embedded in a concrete footing.
- **Model APT/G-6** shall have a nominal length of 72".
- **Model APT/G-8** shall have a nominal length of 96".
- Nominal table height shall be 32". Nominal seat height shall be 18-1/2".
- All galvanized carriage bolts and nuts shall be provided for table assembly.
- **Standard:** All frame components shall be hot-dip galvanized after fabrication to ASTM-A123 to maintain an average zinc coating of 2.0 oz. per sq. ft. of surface area (indicated by "/G" in model no.).
- **Standard:** Tops and seats shall be made of 100% Recycled Plastic molded into 2" x 10" nominal sized planks with solid Cedar colored (indicated by "PC" in model no.) formed throughout and a U.V. stabilizer added for ultra-violet protection.
e.g. APT/B-6PC.
- Recycled Plastic table top and seat planks shall be supported by pregalvanized steel subframe channels.
- **Optional:** 100% Recycled Plastic top and seat planks shall be available in a choice of optional colors. For optional colors choices see Specification Bulletin # SPC-CO-001.
- **Optional:** Color choices of powder coated steel frame components. For optional colors choices see Specification Bulletin # SPC-CO-001.
- **Optional:** Frame shall be provided with a 3/8" x 8" x 8" steel base plate to bolt table to existing concrete pad. To specify add "/P" after the "APT" in the model no., e.g. APT/P/G-6PC. (Anchor bolts not included.)

AVAILABLE OPTIONS

- 6 or 8 foot lengths
- Choice of colors of Powder Coat Finish for steel frame components
- Choice of colors of recycled plastic
- Surface mount base plate

RJThomas Mfg. Co., Inc.

PO Box 946 • Cherokee, IA 51012-0946 • PH: 712-225-5115 • 800-762-5002 • FAX: 712-225-5796
E-mail: pilotrock@rjthomas.com • Web Site: <http://www.pilotrock.com>

© 2008 RJThomas Mfg. Co., Inc. PILOT ROCK® Park Products is a registered trademark of RJThomas Mfg. Co., Inc.

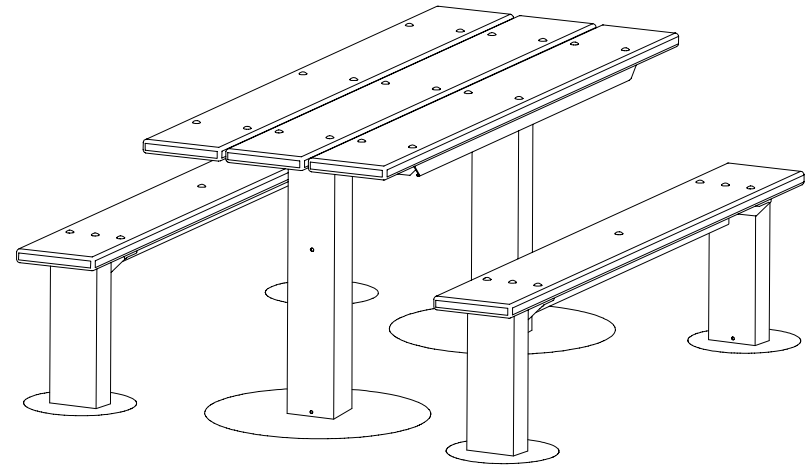
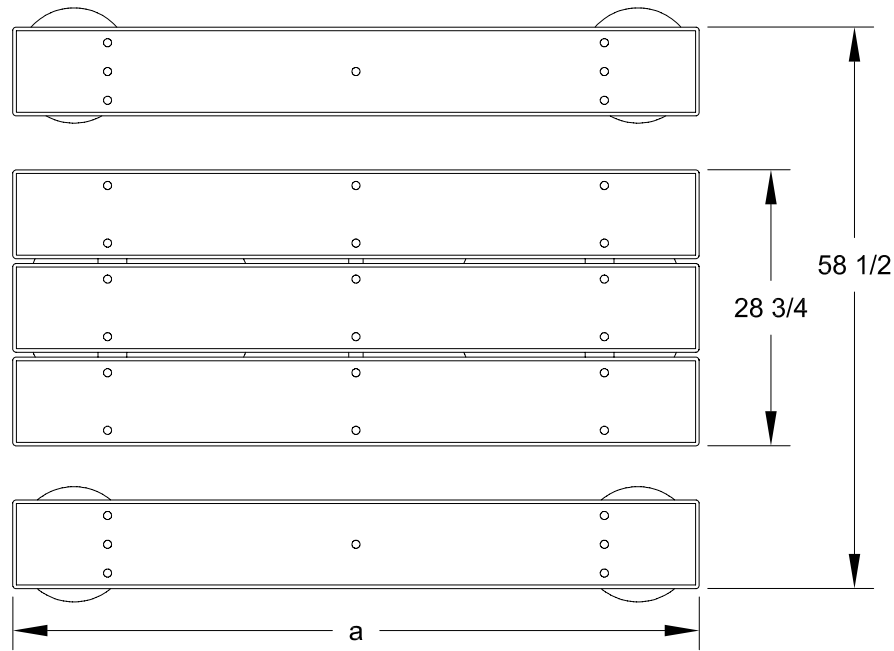

MODEL NUMBER	DIMENSION		
	a	b	c
APT-6	71-1/2	44-3/4	58-3/4
APT-8	95-1/2	63	77

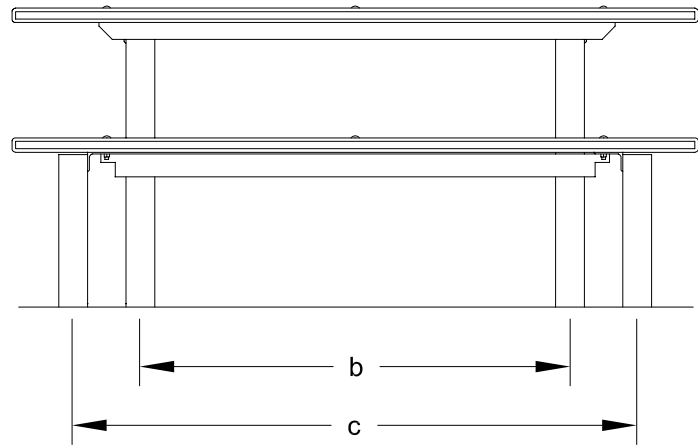

NOTE:
LOCAL SOIL
CONDITIONS
MAY REQUIRE
A LARGER
FOOTING
(CHECK LOCAL
CODES)

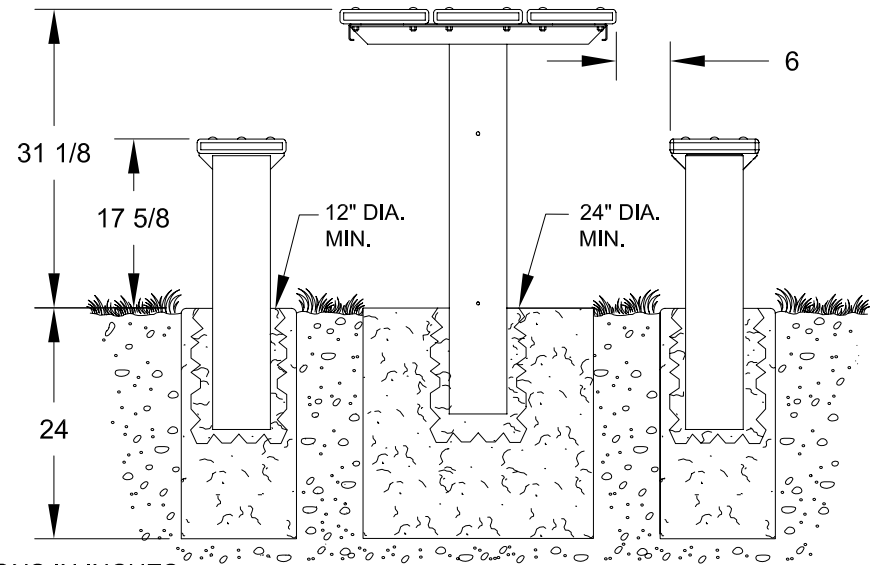

ALL DIMENSIONS IN INCHES

R. J. **THOMAS MFG. CO., INC.**
P.O. Box 946 • Cherokee, IA 51012

DRAWN BY
WWM

TITLE APT SERIES 6 AND 8 FOOT EMBEDDED MOUNT RECTANGULAR DOUBLE PEDESTAL
TABLE WITH RECYCLED PLASTIC TOP AND SEAT PLANKS

DATE 1-08-07

DWG. NO. **AI-1774**