



*Model WUT/G-6HW 6 Ft. Portable, Universal Accessible
Rectangular Table with Hot Dip Galvanized Frames
and Brown Plastisol Coated H-Type Perforated Steel top and seats*

- **Strong 1-5/8" diameter all welded, steel pipe end frame construction**
- **Nontip, nontrip, walk-through design with wheelchair accessibility at each end**
- **Full capacity seating when wheelchairs are not in place**
- **Frames are hot-dip galvanized after fabrication for superior corrosion resistance**
- **Diagonal bracing for strength and rigidity**
- **Plastisol Coating heat fused to Perforated Steel Top for durability**
- **Quality construction throughout**

AVAILABLE OPTIONS

6 or 8 foot lengths

Choice of colors of Powder Coat Finish on steel frame components

Choice of colors of Plastisol Coating

SPECIFICATIONS:

- **WUT Series** end frames shall be one-piece welded construction, fabricated from 1.66" OD x 10 ga. wall steel pipe to meet 1-1/4" nominal steel pipe size specifications with 2" x 2" x 3/16" die-formed steel angle for attaching the top and seats. Bends shall be tightly formed to prevent tipping when weight is on one side.
- The frame design shall provide the ADA recommended wheelchair clearance under the table top of : 30" wide, 27" high, and 24" total knee and toe clearance (19" knee + 5" toe) at each end of the table while maintaining the full seating capacity of the table for common use.
- Table frame shall incorporate nontip, nontrip, walk-through design features.
- **Model WUT/G-6** shall have a nom. 6 ft. length.
- **Model WUT/G-8** shall have a nom. 8 ft. length.
- Nominal table height shall be 30". Frame design shall provide a nominal 28" of clearance from ground level to the underside of table. Nominal seat height shall be 18".
- Frames shall be supported by diagonal braces of 1-5/16" OD x 14 ga. wall steel pipe that shall align and provide attachment to the table top.
- All galvanized fasteners shall be provided for assembly.
- **Standard:** All steel frame components shall be hot-dip galvanized after fabrication to ASTM-A123 to maintain an average zinc coating of 2.0 oz. per sq. ft. of surface area (indicated by "/G" in model no.).
- **H-Type** table top and seats shall each be one-piece welded construction, fabricated from 14 ga. perforated steel surface with 10 ga. x 2-1/2" roll-formed vertical edges on all sides and reinforced by a 10 ga. die-formed angle substructure. Substructure shall include all mounting holes for easy assembly.
- **Standard:** All steel surfaces of the top and seats shall be covered with a coating of Brown vinyl Plastisol (indicated by "HW" in model no.) formulated with high impact additives, UV inhibitors, and an anti-microbial to resist mold and mildew. Plastisol coating shall be permanently heat-fused to the steel to an average thickness of 125 mils (1/8") for an overall average thickness, including top and bottom coatings, of 250 mils (1/4").
- **Optional:** All steel frame components shall have powder coat finish. For color choices see Specification Bulletin # SPC-CO-001.
- **Optional:** Color choices of plastisol coated steel components. For optional colors choices see Specification Bulletin # SPC-CO-001.
- **U.S. Patent Nos. D489,539; D490,992; D493,291; D496,799; D497,262; 6,918,630**

RJThomas Mfg. Co., Inc.

PO Box 946 • Cherokee, IA 51012-0946 • PH: 712-225-5115 • 800-762-5002 • FAX: 712-225-5796
E-mail: pilotrock@rjthomas.com • Web Site: <http://www.pilotrock.com>

© 2008 RJThomas Mfg. Co., Inc. PILOT ROCK® Park Products is a registered trademark of RJThomas Mfg. Co., Inc.

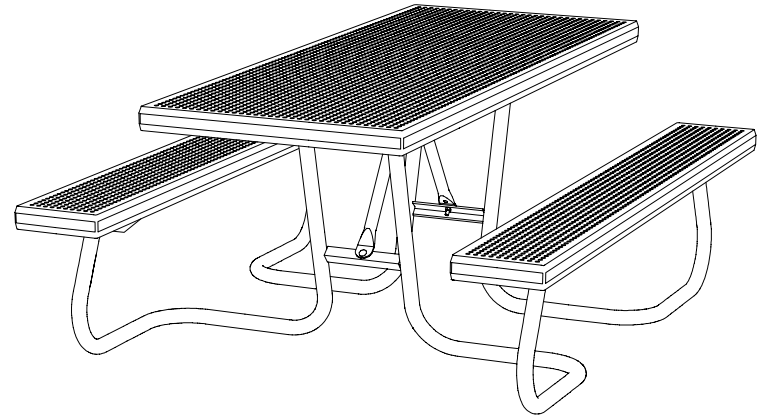
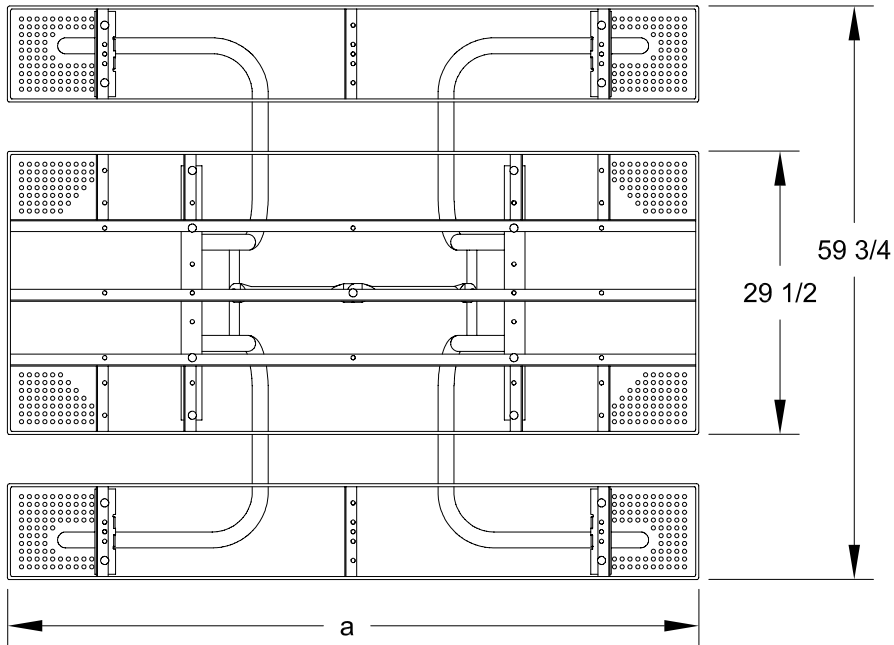

MODEL NUMBER	DIMENSION	
	a	b
WUT-6	72	19-3/4
WUT-8	96	37-5/8

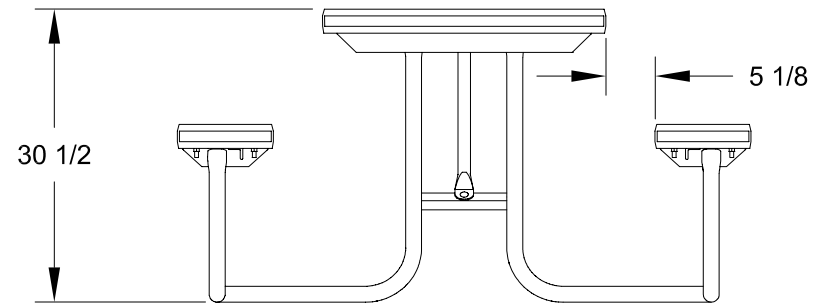
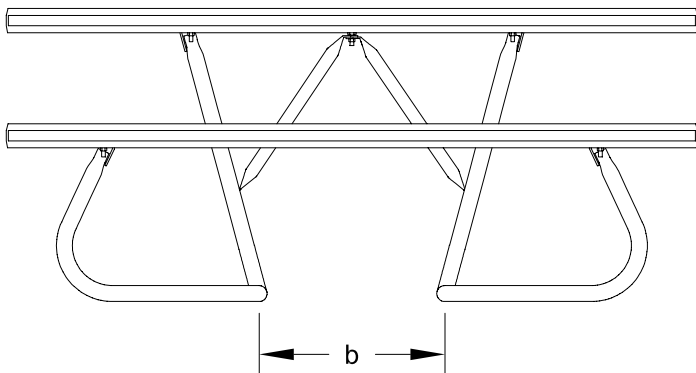

ALL DIMENSIONS IN INCHES

R. J. **THOMAS MFG. Co., Inc.**
P.O. Box 946 • Cherokee, IA 51012

DRAWN BY
WWM

TITLE MODEL WUT 6 AND 8 FOOT UNIVERSAL ACCESSIBLE RECTANGULAR TABLE WITH
PLASTISOL COATED H-TYPE PERFORATED STEEL TOP AND SEATS

DATE 6-21-07

DWG. NO. **AI-1791**