



*Model UTH/CR-6VU/E, 6 ft., Heavy Duty Wheelchair
Accessible Portable Table, Extended 2 ft. One End,
with Red Powder Coated Frames and Blue Plastisol Coated
V-Type Expanded Steel Top and Seats*

- **ADA compliant wheelchair accessibility at one end**
- **Nontip, nontrip walk-through design**
- **All welded end frames are fabricated from 1.66" diameter steel pipe**
- **Diagonal braces align and strengthen entire table**
- **Frames are hot dip galvanized after fabrication for superior corrosion resistance**
- **Plastisol Coating heat fused to Expanded Steel Top for durability**
- **Fast, easy assembly using 3/8" dia. galvanized carriage bolts**
- **Limited lifetime warranty on frames**

AVAILABLE OPTIONS

- **Powder Coat Finish in choice of colors for steel frame components**
- **Choice of colors of Plastisol Coating**

SPECIFICATIONS:

- **UTH Series** end frames shall be one-piece welded construction, fabricated from 1.660" O.D. (1-5/8" O.D.) steel pipe to meet 1-1/4" nominal pipe size specifications with 2" x 2" x 3/16" A-36 structural grade steel angle for attaching the seats and tops. Steel frame pipe is welded on as "outriggers" for added stability.
- Table frame design shall incorporate nontip, nontrip, walk-through design features. Bends shall be tightly formed to prevent tipping when weight is on one side.
- Table shall provide one wheelchair space at one end of table by extending the top 2 ft. creating a ADA recommended space of 30" wide, 19" deep, and 27" from ground to bottom of table top for knee space, and minimum 9" above ground extending a total of 24" deep for toe space. Indicated by "/E" at end of model no.
- A diagonal brace of 1-5/16" O.D. steel pipe and a die-formed steel channel shall be provided to support extended portions of table top and maintain planks against warping.
- **Model UTH/G-6VW/E** shall have a nom. 8 ft. long top and 6 ft. long seats.
- Frame design shall provide a nominal 30" of clearance from ground level to the underside of the table top and nominal seat top height of 21".
- Frames shall be supported by diagonal braces of 1-5/16" O.D. steel pipe.
- All fasteners shall be provided for assembly.
- **Standard:** All steel frame components shall be hot-dip galvanized after fabrication to ASTM-A123 to maintain an average zinc coating of 2.0 oz. per sq. ft. of surface area (indicated by "/G" in model no., e.g. UTH/G-6VW/E).
- **V-Type** table top and seats shall each be a one-piece welded construction, fabricated from a 3/4-#9 expanded steel surface with 10 ga. x 2-1/2" roll-formed vertical edges on all sides and reinforced by a 10 ga. die-formed angle substructure. Substructure shall include all mounting holes for easy assembly of table.
- **Standard:** All steel surfaces of the top and seats shall be covered with a coating of Brown vinyl Plastisol (indicated by "VW" in model no., e.g. UTH/G-6VW/E) formulated with high impact additives, UV inhibitors, and an anti-microbial to resist mold and mildew. Plastisol coating shall be permanently heat-fused to the steel to an average thickness of 125 mils (1/8") for an overall average thickness, including top and bottom coatings, of 250 mils (1/4").
- **Optional:** All steel frame components shall have powder coat finish. For color choices see Specification Bulletin #SPC-CO-001.
- **Optional:** Color choices of plastisol coated steel components. For optional color choices see Specification Bulletin #SPC-CO-001.

RJThomas Mfg. Co., Inc.

PO Box 946 • Cherokee, IA 51012-0946 • PH: 712-225-5115 • 800-762-5002 • FAX: 712-225-5796
E-mail: pilotrock@rjthomas.com • Web Site: <http://www.pilotrock.com>

© 2008 RJThomas Mfg. Co., Inc. PILOT ROCK® Park Products is a registered trademark of RJThomas Mfg. Co., Inc.

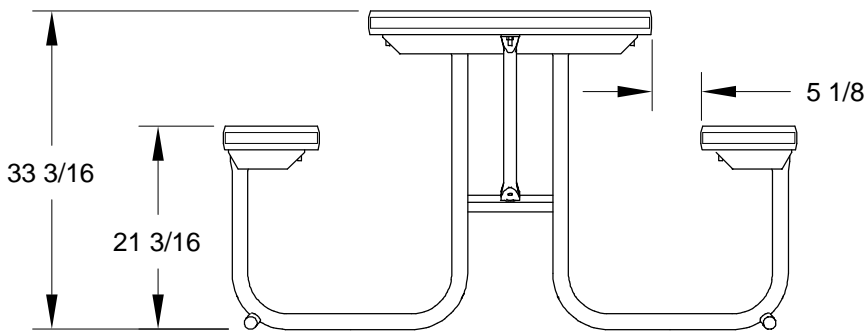
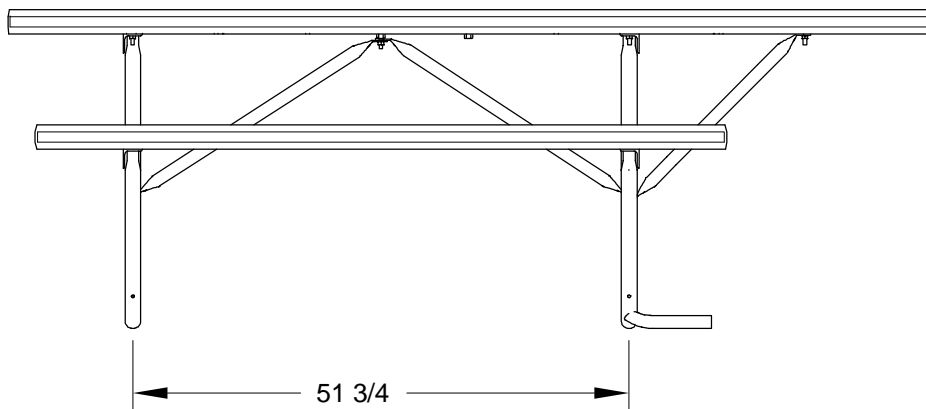
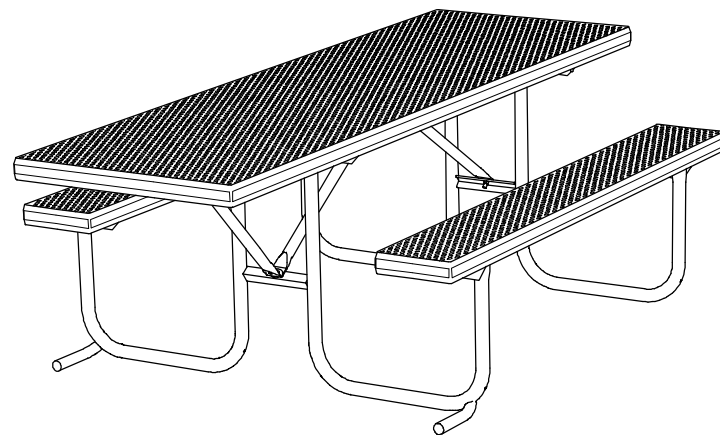
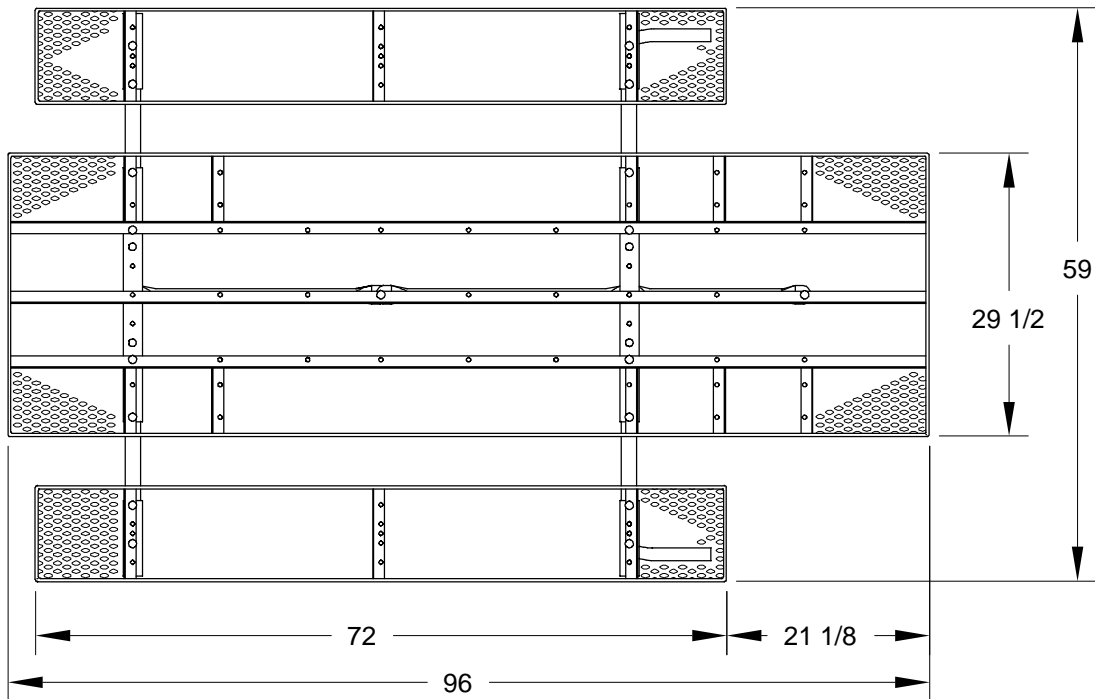

ALL DIMENSIONS IN INCHES

R. J. **THOMAS MFG. Co., Inc.**
 P.O. Box 946 • Cherokee, IA 51012

DRAWN BY
WWM

TITLE **UTH SERIES 6 FOOT RAISED TOP PORTABLE RECTANGULAR TABLE
 WITH TOP EXTENDED 2 FEET ON ONE END WITH V-TYPE PLASTISOL COATED
 EXPANDED STEEL TOP AND SEATS**

DATE 10-22-07

DWG. NO. **AI-1759**