



Model SQT3/CY-4PR/E Wheelchair accessible square portable table with Yellow Powder Coated frames and Red Recycled Plastic top and seats. Top extended one foot on open side.

- **Three seats and one open side for wheelchair access**
- **Square design optimizes table top usage and creates a more intimate setting**
- **Nontip, nontrip walk-through design**
- **All welded corner frames are fabricated from 1-1/2" diameter steel pipe**
- **Cross braces strengthen the table**
- **Frames are hot dip galvanized after fabrication for superior corrosion resistance**
- **100% Recycled Plastic Seat and Top Planks with solid color and U.V. stabilizer for ultraviolet protection**
- **Quality construction throughout**

SPECIFICATIONS:

- **Model SQT3-4** shall have a nominal 4' x 5' top. Overall dimensions shall be 73-3/8" x 75-1/8".
- Four corner frames shall each be of one-piece welded construction made from 1-1/2" dia. x 1/8" wall structural steel tubing and 1-3/4" x 1-3/4" x 1/8" A-36 structural steel angle. Two corner frames shall have opposing seat legs removed to provide a wheelchair accessible space under the extended side of the table top.
- Table frame design shall incorporate the nontip, nontrip, walk-through features. Bends shall be tightly formed to prevent tipping when weight is on one side.
- Table top shall be extended 12" over open side of table creating ADA recommended space of 30" wide, 19" deep, and 27" from ground to bottom of table top for knee space, and minimum 9" above ground extending a total of 24" deep for toe space. Indicated by "/E" in model no.
- Nominal table height shall be 30". Nominal seat height shall be 17-1/2".
- Corner frames shall be connected by two cross braces constructed of 1-5/16" O.D. steel pipe.
- Top planks shall be supported and attached to corner frames by two 1-3/4" x 1-3/4" x 1/8" structural steel top angles.
- All fasteners shall be provided for assembly.
- **Standard:** All steel frame components shall be hot-dip galvanized after fabrication to ASTM-A123 to maintain an average zinc coating of 2.0 oz. per sq. ft. of surface area (indicated by "/G" in model no., e.g. SQT3/G-4PC/E).
- **Standard:** Tops and seats shall be made of 100% Recycled Plastic molded into 2" x 10" nominal sized planks with solid Cedar color (indicated by PC in model no., e.g. SQT3/G-6PC/E) formed throughout and a U.V. stabilizer added for ultra-violet protection.
- **Optional:** All steel frame components shall have powder coat finish. For color choices see Specification Bulletin #SPC-CO-001.
- **Optional:** Color choices of Recycled Plastic components. For optional colors choices see Specification Bulletin # SPC-CO-001.

AVAILABLE OPTIONS

- **Powder Coat Finish in choice of colors for steel frame components**
- **Choice of colors of Recycled Plastic**

RJThomas Mfg. Co., Inc.

PO Box 946 • Cherokee, IA 51012-0946 • PH: 712-225-5115 • 800-762-5002 • FAX: 712-225-5796
E-mail: pilotrock@rjthomas.com • Web Site: <http://www.pilotrock.com>

© 2008 RJThomas Mfg. Co., Inc. PILOT ROCK® Park Products is a registered trademark of RJThomas Mfg. Co., Inc.

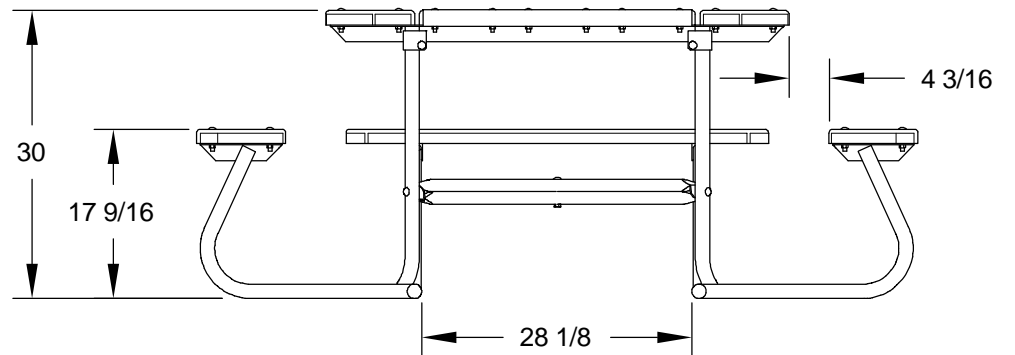
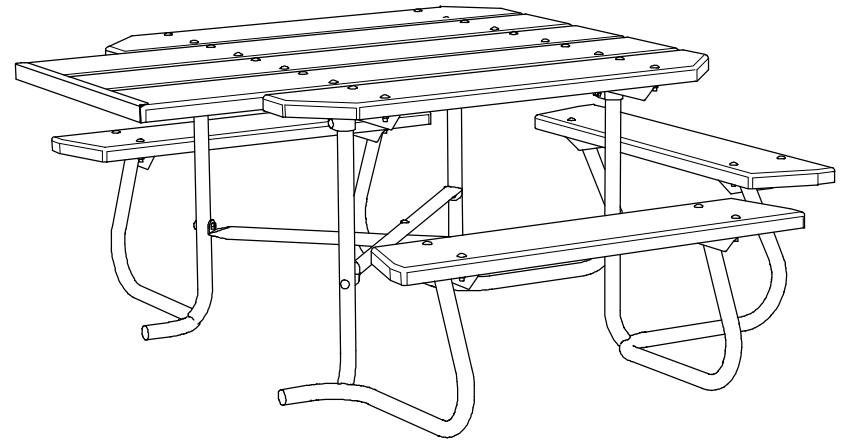
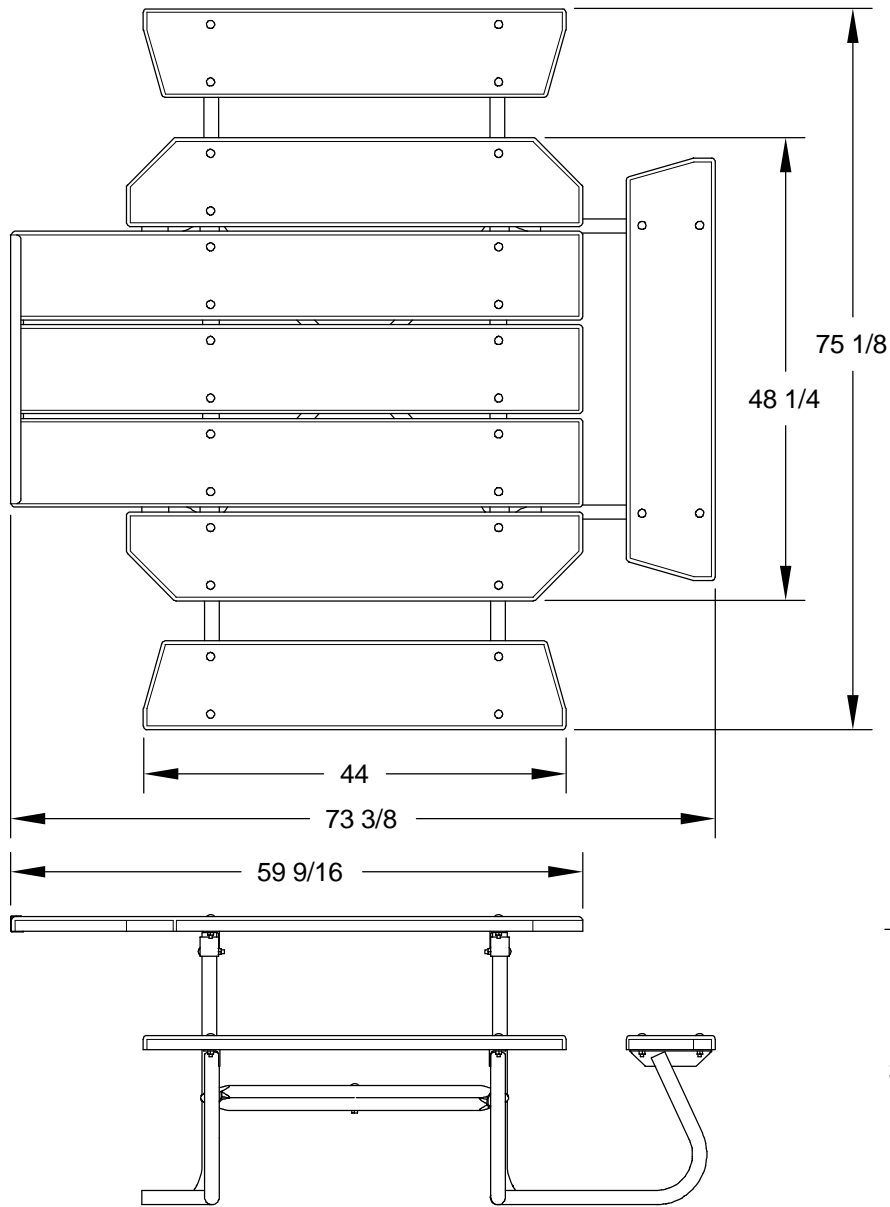

ALL DIMENSIONS IN INCHES

R. J. **THOMAS MFG. Co., Inc.**
P.O. Box 946 • Cherokee, IA 51012

DRAWN BY
WWM

TITLE **SQT3-4 SERIES 4 FOOT PORTABLE SQUARE TABLE WITH RECYCLED PLASTIC SEATS AND TOP TOP EXTENDED ONE FOOT ON OPEN SIDE**

DATE **03-18-08**

DWG. NO. **AI-1833**