



*Model SQT3/G-4VN/E Wheelchair accessible square portable table with Hot Dip Galvanized frames and Plastisol Coated V-Type Expanded Steel top and seats. Top extended one foot on open side.*

- **Three seats and one open side for wheelchair access**
- **Square design optimizes table top usage and creates a more intimate setting**
- **Nontip, nontrip walk-through design**
- **All welded corner frames are fabricated from 1-1/2" diameter steel pipe**
- **Cross braces strengthen the table**
- **Frames are hot dip galvanized after fabrication for superior corrosion resistance**
- **Plastisol Coating heat fused to Expanded Steel Top for durability**
- **Quality construction throughout**

#### **AVAILABLE OPTIONS**

- **Powder Coat Finish in choice of colors for steel frame components**
- **Choice of colors of Plastisol Coating**

#### **SPECIFICATIONS:**

- **Model SQT3-4** shall have a nominal 4' x 5' top. Overall dimensions shall be 73-3/8" x 75-1/8".
- Four corner frames shall each be of one-piece welded construction made from 1-1/2" dia. x 1/8" wall structural steel tubing and 1-3/4" x 1-3/4" x 1/8" A-36 structural steel angle. Two corner frames shall have opposing seat legs removed to provide a wheelchair accessible space under the extended side of the table top.
- Table frame design shall incorporate the nontip, nontrip, walk-through features. Bends shall be tightly formed to prevent tipping when weight is on one side.
- Table top shall be extended 12" over open side of table creating ADA recommended space of 30" wide, 19" deep, and 27" from ground to bottom of table top for knee space, and minimum 9" above ground extending a total of 24" deep for toe space. Indicated by "/E" in model no.
- Nominal table height shall be 30". Nominal seat height shall be 17-1/2".
- Corner frames shall be connected by two cross braces constructed of 1-5/16" O.D. steel pipe.
- Top shall be supported and attached to corner frames by two 1-3/4" x 1-3/4" x 1/8" structural steel top angles.
- All fasteners shall be provided for assembly.
- **Standard:** All steel frame components shall be hot-dip galvanized after fabrication to ASTM-A123 to maintain an average zinc coating of 2.0 oz. per sq. ft. of surface area (indicated by "/G" in model no., e.g. SQT3/G-4VW/E).
- **V-Type** table top and seats shall be a one-piece welded construction, fabricated from a 3/4"-#9 expanded steel surface with 2" roll-formed 14 ga. steel vertical edges on all sides and reinforced by a strap and die-formed angle substructure.
- **Standard:** All steel surfaces of the top and seats shall be covered with a coating of Brown vinyl Plastisol (indicated by "VW" in model no., e.g. SQT3/G-4VW/E) formulated with high impact additives, UV inhibitors, and an anti-microbial to resist mold and mildew. Plastisol coating shall be permanently heat-fused to the steel to an average thickness of 125 mils (1/8") for an overall average thickness, including top and bottom coatings, of 250 mils (1/4").
- **Optional:** All steel frame components shall have powder coat finish. For color choices see Specification Bulletin #SPC-CO-001.
- **Optional:** Color choices of plastisol coated steel components. For optional color choices see Specification Bulletin #SPC-CO-001.

### **RJThomas Mfg. Co., Inc.**

PO Box 946 • Cherokee, IA 51012-0946 • PH: 712-225-5115 • 800-762-5002 • FAX: 712-225-5796  
E-mail: pilotrock@rjthomas.com • Web Site: <http://www.pilotrock.com>

© 2008 RJThomas Mfg. Co., Inc. PILOT ROCK® Park Products is a registered trademark of RJThomas Mfg. Co., Inc.

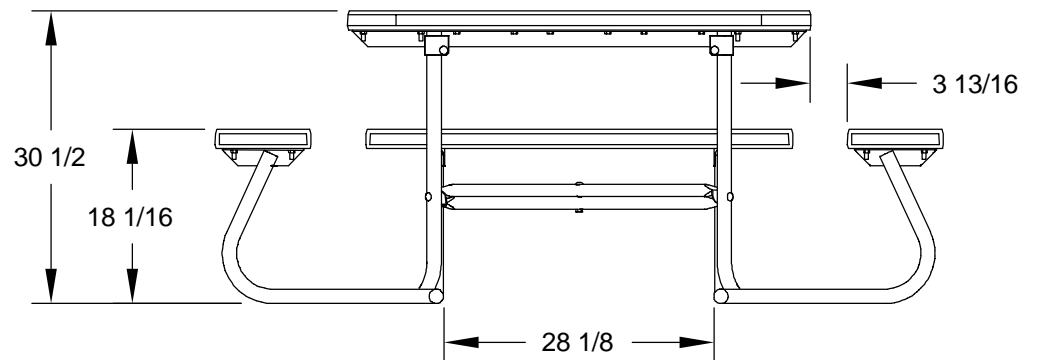
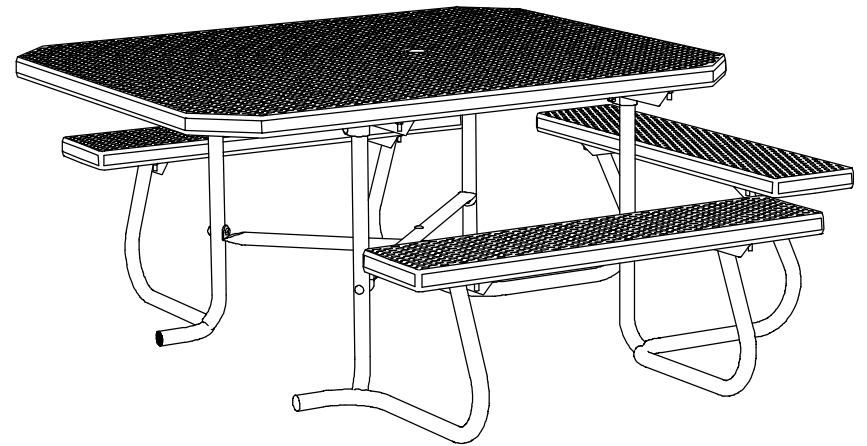
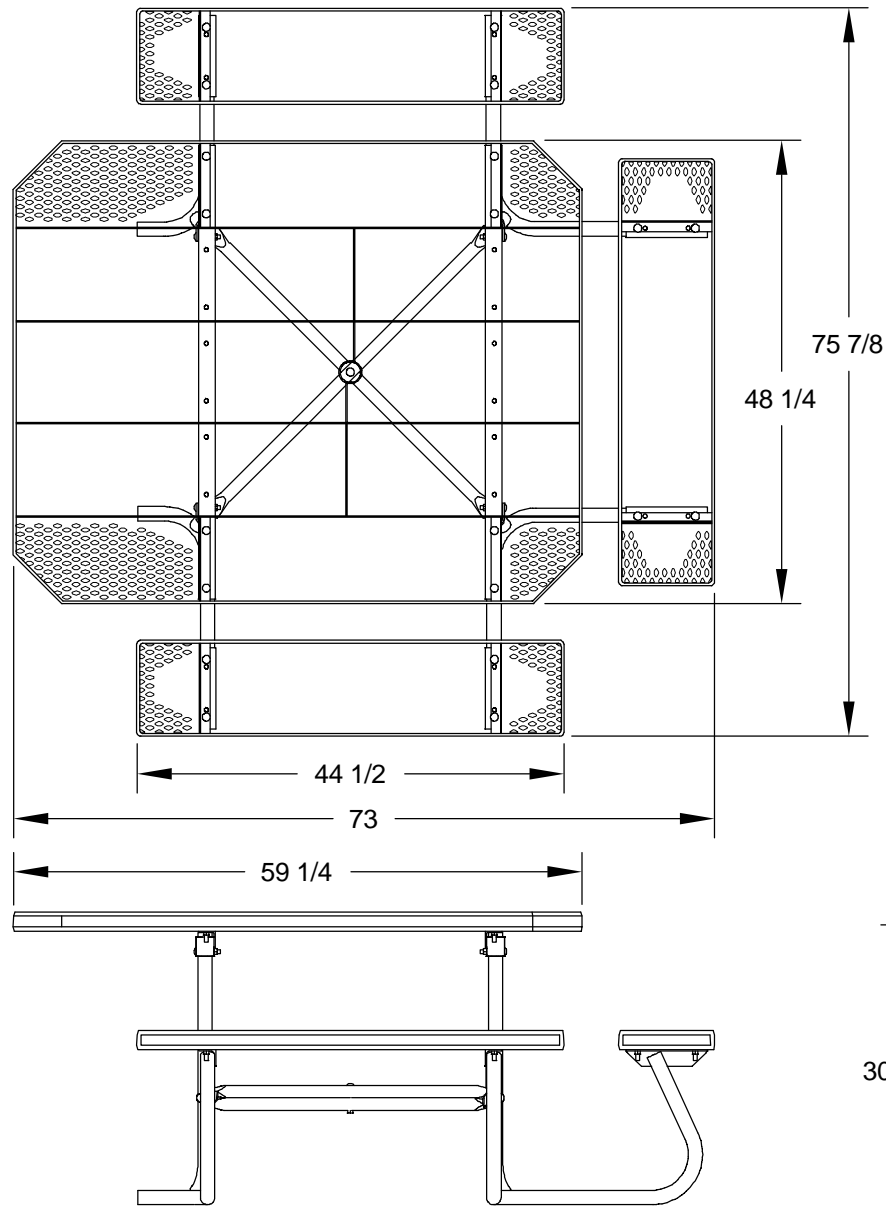

ALL DIMENSIONS IN INCHES

R. J. **THOMAS MFG. Co., Inc.**  
P.O. Box 946 • Cherokee, IA 51012

DRAWN BY  
**WWM**

TITLE **SQT3-4 SERIES 4 FOOT PORTABLE SQUARE TABLE WITH PLASTISOL COATED EXPANDED STEEL TOP AND SEATS, TOP EXTENDED ONE FOOT ON OPEN SIDE**

DATE **03-13-08**

DWG. NO. **AI-1831**