

# UT Series 10 and 12 Foot Rectangular Table with Aluminum Top and Seats



*Model UT/G-12AL 12 Ft. Heavy Duty Portable Rectangular Table with Hot Dip Galvanized Frame and Aluminum top and seats.*

- **Nontip, nontrip, walk-through design**
- **All welded end frames are fabricated from 1.66" diameter steel pipe**
- **Die-formed center channel and diagonal braces align and strengthen entire table**
- **Frames are hot dip galvanized after fabrication for superior corrosion resistance**
- **Seats and Top are Aluminum with a clear anodized maintenance free finish**
- **Fast, easy assembly using 3/8" dia. galvanized carriage bolts**
- **Limited lifetime warranty on frames**

## AVAILABLE OPTIONS

**10' or 12' length**

**Powder Coat Finish in choice of colors on steel frame components**

**Powder coated finish in choice of colors on aluminum top and seats**

## SPECIFICATIONS:

- **UT Series** end frames shall be one-piece welded construction, fabricated from 1.660" O.D. (1-5/8" O.D.) steel pipe to meet 1-1/4" nominal pipe size specifications with 2" x 2" x 3/16" A-36 structural grade steel angle for attaching the seats and tops.
- Table frame design shall incorporate nontip, nontrip, walk-through design features.
- Nominal table height, 30". Nominal seat height, 18".
- **Model UT/G-10AL** shall be a nominal 10 ft. long with three frames.
- **Model UT/G-12AL** shall be a nominal 12 ft. long with three frames.
- Frames shall be supported by diagonal braces of 1-5/16" O.D. x 14 ga. wall steel pipe that shall connect to a die-formed steel channel designed to align and provide attachment to the table top.
- **Standard:** All steel frame components shall be hot-dip galvanized after fabrication to ASTM-A123 to maintain an average zinc coating of 2.0 oz. per sq. ft. of surface area (indicated by "/G" in model no., e.g. UT/G-10AL).
- All fasteners shall be provided for assembly.
- Aluminum shall be extruded 6063-T6 aluminum alloy in planks with dimensions equivalent to that of 2" x 10" nominal sized lumber. The plank design shall be 1-3/4" x 9-5/8" with four structural reinforcement ribs for greater rigidity. Aluminum planks shall be provided with a clear anodized finish as per anodizing specification 204 R1. Aluminum clips to fasten planks to frames are included.
- Channel end caps shall be of extruded 6063-T6 aluminum alloy provided with a clear anodized finish as per anodizing specification 204 R1. End caps shall be press fitted over ends of aluminum planks and mechanically fastened in place at the factory.
- Table tops are assembled into single units at the factory with one-piece end caps across each end.
- **Optional:** All steel frame components shall have powder coat finish. For color choices see Specification Bulletin #SPC-CO-001.
- **Optional:** Aluminum top and seat planks shall have powder coat finish. For color choices see Specification Bulletin #SPC-CO-001.

**RJThomas Mfg. Co., Inc.**

PO Box 946 • Cherokee, IA 51012-0946 • PH: 712-225-5115 • 800-762-5002 • FAX: 712-225-5796  
E-mail: pilotrock@rjthomas.com • Web Site: <http://www.pilotrock.com>

© 2008 RJThomas Mfg. Co., Inc. PILOT ROCK® Park Products is a registered trademark of RJThomas Mfg. Co., Inc.

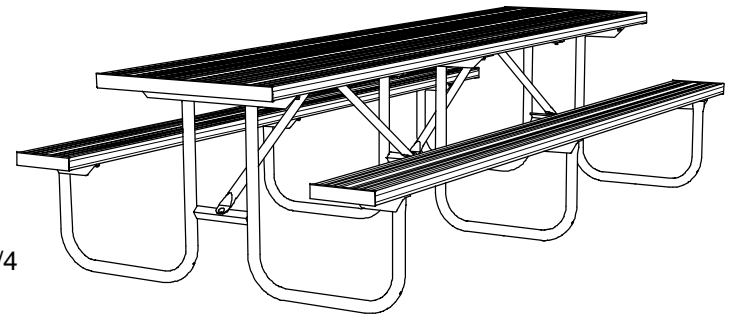
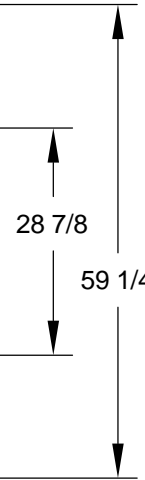
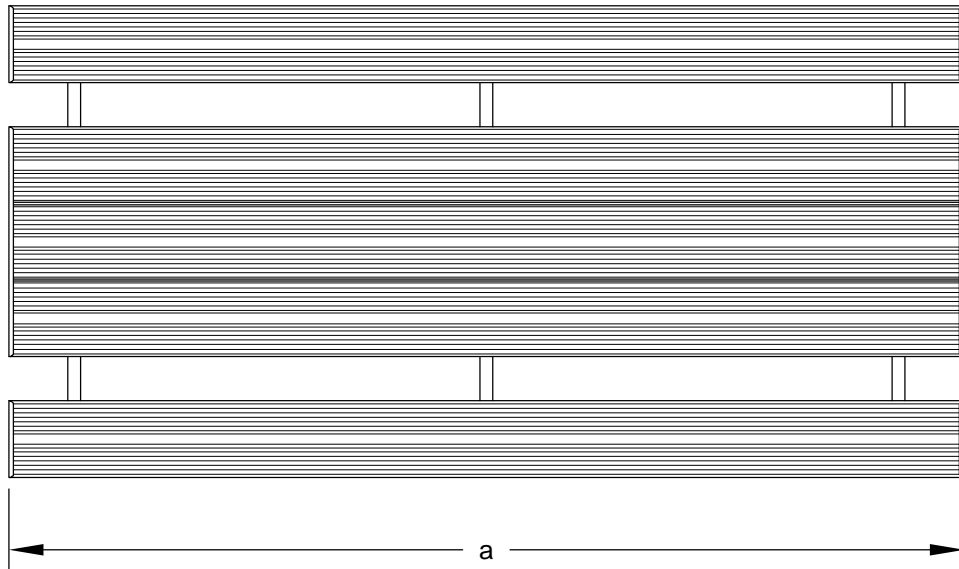

MODEL NUMBER	DIMENSION	
	a	b
UT-10	120	51-3/4
UT-12	144	60-7/8

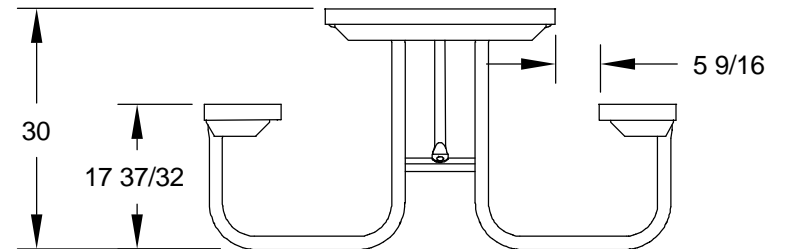
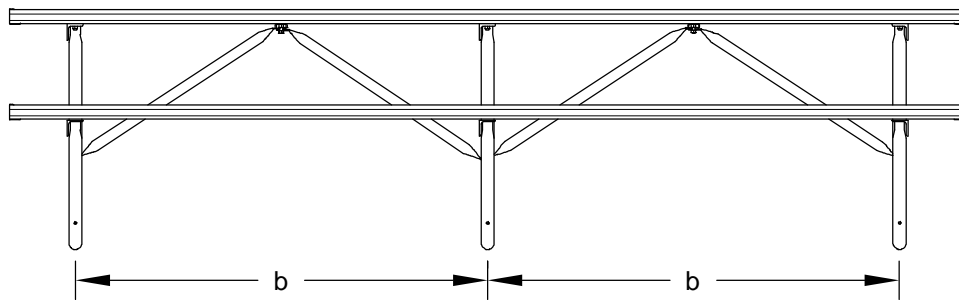

R. J. **THOMAS MFG. Co., INC.**  
 P.O. Box 946 • Cherokee, IA 51012

DRAWN BY  
**WWM**

TITLE UT SERIES HEAVY DUTY 10 AND 12 FOOT PORTABLE RECTANGULAR TABLE WITH ALUMINUM TOP AND SEATS

DATE 3-2-08

DWG. NO. AI-1828