



Model WPTS/G-6PN Universal accessible portable rectangular table,
6 ft. long with Hot Dip Galvanized frames
and Green Recycled Plastic top and seats

- **Nontip, nontrip, walk-through design, wheelchair accessibility at each end**
- **Full capacity seating when wheelchairs are not in place**
- **All welded end frames are fabricated from 3" x 6" rectangular and 2-1/2" square steel tubing**
- **Diagonal braces align and strengthen entire table**
- **Frames are hot dip galvanized after fabrication for superior corrosion resistance**
- **100% Recycled Plastic Seat and Top Planks with solid color and U.V. stabilizer for ultraviolet protection**
- **Fast, easy assembly using 3/8" dia. galvanized carriage bolts**

AVAILABLE OPTIONS

- 6' or 8' lengths
- Powder Coat Finish in choice of colors on steel frame components
- Choice of colors of Recycled Plastic

SPECIFICATIONS:

- **WPTS Series** end frames shall be one-piece welded construction, fabricated from 3" x 6" x 1/8" wall rectangular steel tube top and seat supports connected by 2-1/2" x 1/8" wall square tube with 2" x 2" x 3/16" die-formed steel angle for attaching seats and tops.
- Frame design shall provide the ADA recommended wheelchair clearances under the table top of: 30" wide, 27" high and 24" total knee and toe clearance (19" knee + 5" toe) at each end of the table while maintaining full seating capacity of the table.
- Frame design incorporates nontip, nontrip, walk-through features.
- **Model WPTS/G-6** shall be a nom. 6 ft. in length.
- **Model WPTS/G-8** shall be a nom. 8 ft. in length.
- Nominal table height shall be 31". Frame design shall provide a nominal 28" of clearance from ground level to the underside of table. Nominal seat height shall be 18".
- Frames shall be supported by diagonal braces of 1-5/16" O.D. x 14 ga. wall steel pipe connected to the table top.
- All 3/8" dia. galvanized carriage bolts and nuts shall be provided to fasten frames to top and seats.
- **Standard:** All steel frame components shall be hot-dip galvanized after fabrication to ASTM-A123 to maintain an average zinc coating of 2.0 oz. per sq. ft. of surface area (indicated by "/G" in model no., e.g. WPTS/G-6PC).
- **Standard:** Tops and seats shall be made of 100% Recycled Plastic molded into 2" x 10" nominal sized planks with solid Cedar color (indicated by "PC" in model no.) formed throughout and a U.V. stabilizer added for ultra-violet protection.
- Recycled Plastic table top and seat planks shall be supported by pregalvanized steel subframe channels.
- **Optional:** All steel frame components shall have powder coat finish. For color choices see Specification Bulletin #SPC-CO-001.
- **Optional:** Color choices of recycled plastic components. For optional colors choices see Specification Bulletin # SPC-CO-001.
- **U.S. Patent Nos. D489,539; D490,992; D493,291; D496,799; D497,262; 6,918,630**

RJThomas Mfg. Co., Inc.

PO Box 946 • Cherokee, IA 51012-0946 • PH: 712-225-5115 • 800-762-5002 • FAX: 712-225-5796
E-mail: pilotrock@rjthomas.com • Web Site: <http://www.pilotrock.com>

© 2008 RJThomas Mfg. Co., Inc. PILOT ROCK® Park Products is a registered trademark of RJThomas Mfg. Co., Inc.

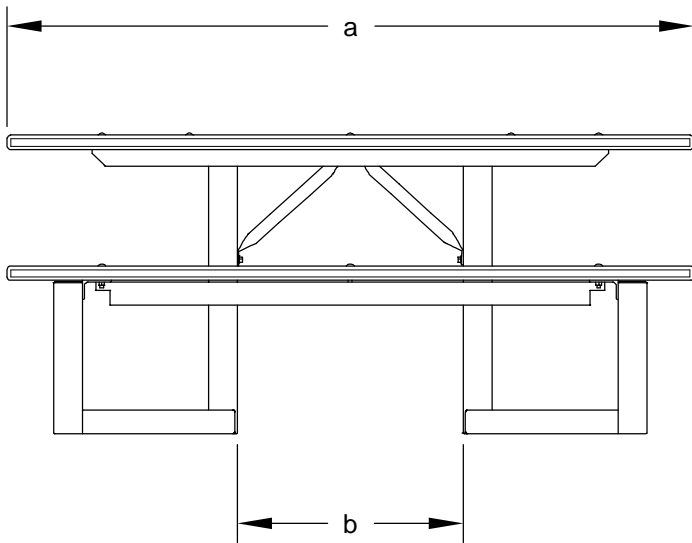
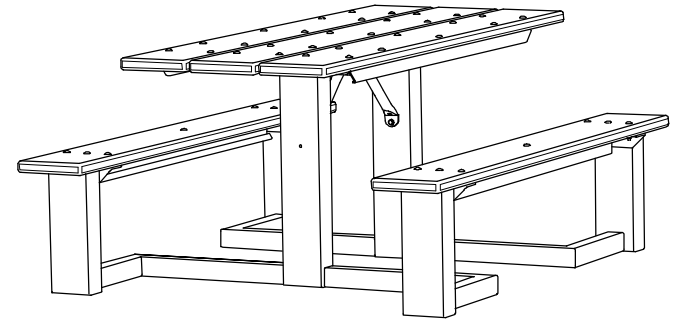
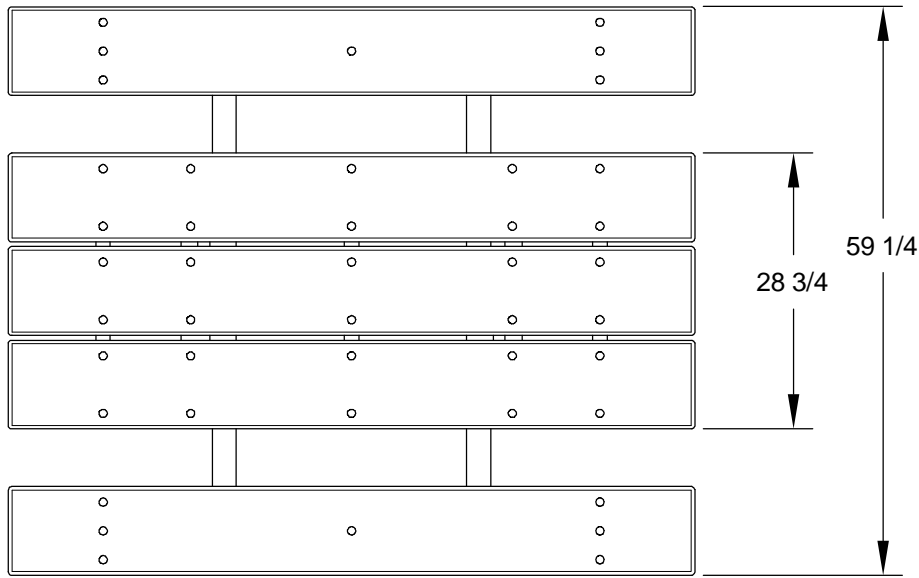

MODEL NUMBER	DIMENSION	
	a	b
WPTS-6	71 1/2	23 1/2
WPTS-8	95 1/2	14 3/4

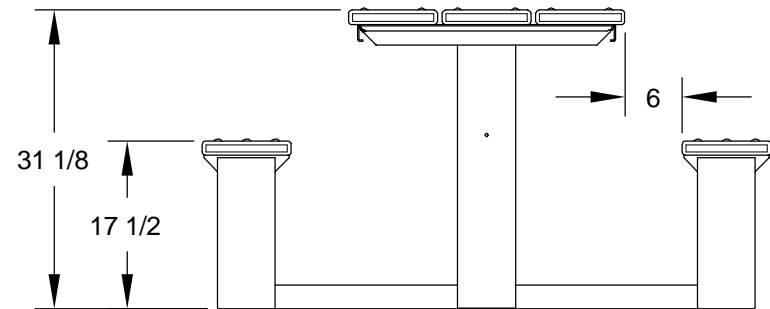

ALL DIMENSIONS IN INCHES

R. J. **THOMAS MFG. Co., Inc.**
P.O. Box 946 • Cherokee, IA 51012

DRAWN BY
WWM

TITLE
WPTS SERIES 6 AND 8 FOOT UNIVERSAL ACCESS TABLES WITH 2" X 10"
RECYCLED PLASTIC TOP AND SEAT PLANKS

DATE 3-17-08

DWG. NO. AI-1832